

# **GERMAN WORLD WAR II ORGANIZATIONAL SERIES**

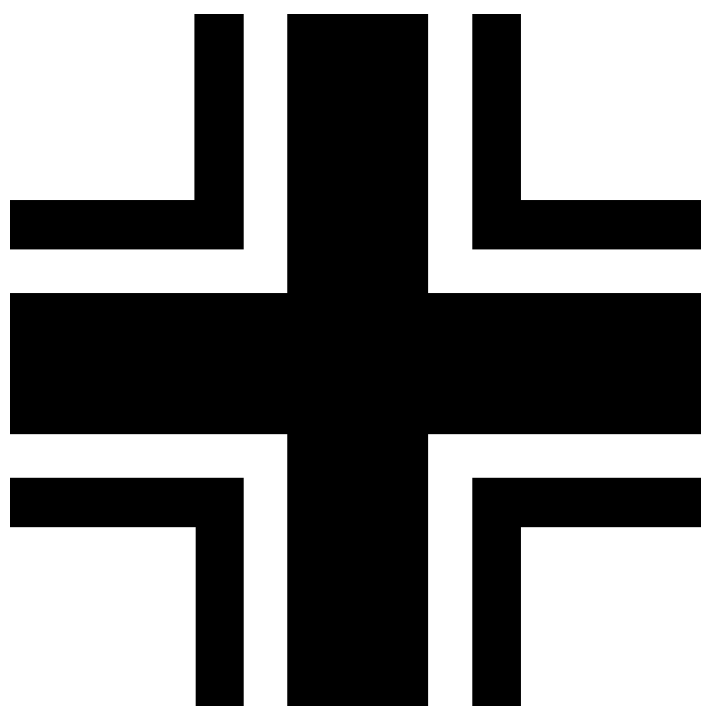

**Volume 1/I**

**MECHANIZED ARMY DIVISIONS AND WAFFEN-SS UNITS  
(1.09.1939)**

## **THE GERMAN WORLD WAR II ORGANIZATIONAL SERIES**

1/I	01.09.39	Mechanized Army Formations and Waffen-SS Formations (3rd Revised Edition)
1/II-1	01.09.39	1 <sup>st</sup> and 2 <sup>nd</sup> Welle Army Infantry Divisions
1/II-2	01.09.39	3 <sup>rd</sup> and 4 <sup>th</sup> Welle Army Infantry Divisions
1/III	01.09.39	Higher Headquarters — Mechanized GHQ Units — Static Units (2nd Revised Edition)
2/I	10.05.40	Mechanized Army Formations and Waffen-SS Formations (2nd Revised Edition)
2/II	10.05.40	Higher Headquarters and Mechanized GHQ Units (2nd Revised Edition)
3/I	22.06.41	Mechanized Army Divisions - (2nd Revised Edition)
3/II	22.06.41	Higher Headquarters and Mechanized GHQ Units (2nd Revised Edition)
4/I	28.06.42	Mechanized Army Divisions - (2nd Revised Edition)
4/II	28.06.42	Mechanized GHQ Units and Waffen-SS Formations
5/I	04.07.43	Mechanized Army Formations
5/II	04.07.43	Higher Headquarters and Mechanized GHQ Units
5/III	04.07.43	Waffen-SS Higher Headquarters and Mechanized Formations

### **IN PREPARATION FOR PUBLICATION 2007/2008**

7/I	06.06.44	Mechanized Army Formations
2/III	10.05.40	Army Infantry Divisions
3/III	22.06.41	Army Infantry Divisions

### **IN PREPARATION FOR PUBLICATION**

01.09.39	Landwehr Division — Mountain Divisions — Cavalry Brigade
10.05.40	Non-Mechanized GHQ Units Static Units
22.06.41	Mechanized Waffen-SS Formations Static Units
28.06.42	Higher Headquarters Army Divisions Static Units
04.07.43	Army Divisions Static Units
01.11.43	Mechanized Army Formations Mechanized GHQ Units Mechanized Waffen-SS Formations Army Divisions Static Units Higher Headquarters
06.06.44	Mechanized GHQ Units Mechanized Waffen-SS Formations Army Divisions Static Units Higher Headquarters
16.12.44	Mechanized Army Formations Mechanized GHQ Units Mechanized Waffen-SS Formations Army Divisions Static Units Higher Headquarters
1939 – 45	Luftwaffen Ground Combat Forces
1944 – 45	The 1944 Brigades
1939 – 45	Organizational Handbook

# GERMAN WORLD WAR II ORGANIZATIONAL SERIES

*by Leo W.G. Niehorster*

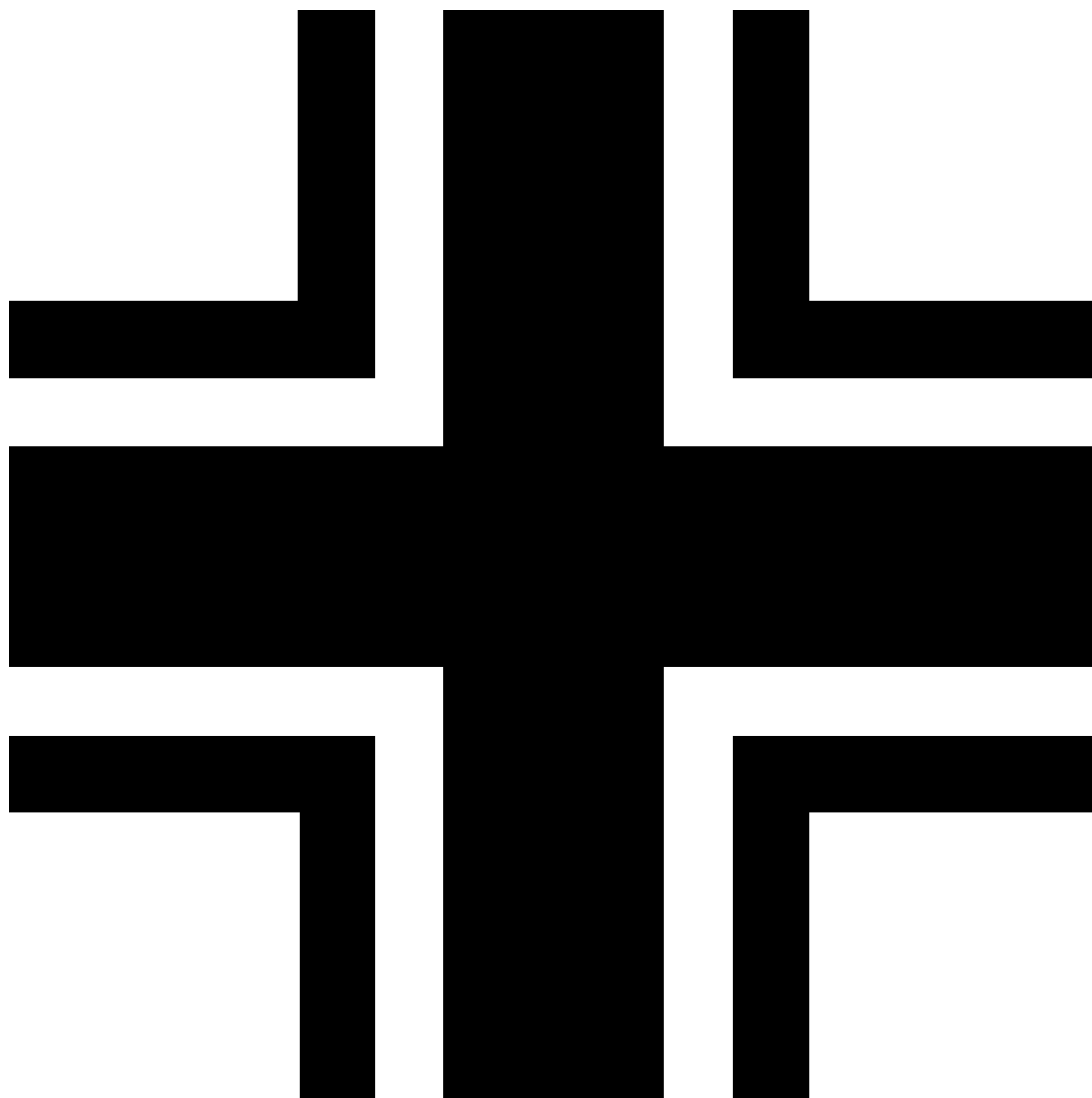

Volume 1/I

**MECHANIZED ARMY DIVISIONS AND WAFFEN-SS UNITS  
(1.09.1939)**

This the edition of  
**GERMAN WORLD WAR II ORGANIZATIONAL SERIES**  
**Volume 1/I**  
Mechanized Army Divisions and GHQ Units  
(1.09.1939)  
was first published by The Military Press in 2004  
Reprinted by The Military Press in 2007  
This and prior editions © by Leo W.G. Niehorster

**THE MILITARY PRESS**  
**1 Gallagher Close**  
**Crownhill, Milton Keynes**  
**Buckinghamshire MK8 OLQ**  
**United Kingdom**  
**Tel: +44 (190) 826-5095**  
**Fax: +44 (870) 912-0908**  
**email: [militarypress@btopenworld.com](mailto:militarypress@btopenworld.com)**  
**<http://www.militarypress.co.uk>**

All rights reserved. Except for use in a review, no portion of this book may be reproduced, stored in a retrieval system or transmitted in any form or means, electronic, electrostatic, magnetic tape, mechanical, photocopying, or otherwise without the express prior, written permission of the publisher. Neither the author nor the publisher assumes any responsibility for the use or misuse of information contained in this book.

Printed in the United Kingdom

ISBN 978-0-85420-234-8 Hardback Edition  
ISBN 978-0-85420-239-3 Softback Edition

## CONTENTS

**Mechanized Army Division and Waffen-SS Units**

1	Contents	42	Motorized Reconnaissance Regiment
2	The Author	44	Combat Engineer Battalion (motorized)
3	General Introduction	45	Divisional Signal Battalion (motorized)
4	How to Read the Charts	46	Divisional Support Services (motorized)
5	Germans Units and Symbols	48	2. Infanterie-Division (motorisiert)
6	Organizational Symbols	50	13. Infanterie-Division (motorisiert)
7	Organizational Symbols	52	20. Infanterie-Division (motorisiert)
8	Abbreviations	54	29. Infanterie-Division (motorisiert)
9	Order of Battle	56	Headquarters, Infantry Division
10	1. Panzer-Division	57	Anti-Tank Battalion
12	2. Panzer-Division	58	Infantry Regiment (motorized)
14	3. Panzer-Division	60	Artillery Regiment (motorized)
16	4. Panzer-Division	62	Motorized Reconnaissance Battalion
18	5. Panzer-Division	63	Combat Engineer Battalion (motorized)
20	1. leichte Division (motorisiert)	64	Divisional Signal Battalion (motorized)
22	2. leichte Division (motorisiert)	65	Divisional Support Services (motorized)
24	3. leichte Division (motorisiert)	66	SS Units – authorized organization
26	4. leichte Division (motorisiert)	67	SS-Standarte (mot)
28	Headquarters, 10. Panzer-Division	68	SS-Artillery Standarte (mot)
29	Headquarters, Panzer Division & Light Mechanized Division	69	SS-Light Antiaircraft Battalion
30	Panzer Brigade	70	SS-Reconnaissance Battalion
31	Panzer Brigade (Sonder)	71	SS-Engineer Battalion
32	Panzer Battalion (Sonder)(LTM 35)	72	SS-Signal Battalion
33	Panzer Battalion (truck-borne)	73	Bibliography
34	Panzer Battalion (truck-borne)(LTM 38)	i	Introduction to Motor Vehicles
35	Motorized Infantry Brigade & OB Infantry units	ii	Numbered Motorized Softskin Vehicles
36	Motorized Infantry Regiment (1. – 3. Pz. Div.)	iv	Special Motorized Vehicles
37	Motorized Infantry Regiment (4. & 5. Pz., 2. & 4. lei. Div)	x	Military Trailers and Special Military Trailers
38	Motorized Infantry Regiment (1. & 3. lei. Div.)	xiii	Horse-Drawn Vehicles: Wagons, Carts, Sleds
39	Anti-Tank Battalion	xv	Ranks and Billet Groups of the German Army
40	Motorized Artillery Regiment	xvi	German Military Personnel Job Descriptions

**THE AUTHOR**

Dr. Leo Niehorster was born in The Hague, Netherlands of an American mother and Dutch father. He has lived in Holland, Peru, England, Mexico, Canada, the United States, France, and Germany. His university education has been correspondingly diverse. The University of the Americas in 1964 to 1967, University of Maryland (correspondence courses while in the US Army) from 1968 to 1972, European Business School 1972 to 1976 (BA in Business Administration), Frankfurt Fachhochschule 1978 (Dipl. Kaufmann), Columbia Pacific University 1978 to 1980 (External MA in Business Administration), Columbia Pacific University 1980 to 1982 (External PhD in History). His vocational training includes a course resulting in the degree of Telecommunications Systems Developer. He is also a licensed Apple Service Technician.

The author did his military service in the US Army from 1968 to 1972, ending up in Germany, where he stayed.

His professional career started as night shift supervisor in an airline catering service, and has spanned such activities as pizza baker at

the local Italian in Barstow, California, to product manager for long haul travel in the world's largest tour operator in Hannover, Germany. He is presently controller for a bank in Germany, and spends most of his spare time involved in military history.

The author is a recognized authority on World War II German ground forces organization, and has put all of his expertise into the present series. Some of these books are a republishing of the original series, (which have been out of print for several years), but they have been very much enhanced and augmented, encompassing a further fourteen years of research and study in the German, American, and British archives. The revised editions as well as the new volumes in the series will be highly welcomed by all interested in German military organization in World War II.

Dr. Niehorster's previously published works include the "The Royal Hungarian Army, 1920–1945", which was acclaimed as one of the Top Ten Books of 1999, and is considered by many experts to be the single most important English language history on the Hungarian Army.

## GENERAL INTRODUCTION

The first thing that must be mentioned is that all mechanized forces of the German Army were in the throes of reorganization when the 1939 Polish Campaign started in September 1939. The leichte Division (motorisiert) – translated here as Light Mechanized Divisions – were in the process of being converted to Panzer-Division – Armored Divisions – and were all in different stages of this process. The Panzer Divisions were being reorganized to accommodate new concepts and new weapons. The 1937/38 Tables of Organization (*Kriegstärke-nachweisung – KStN*) were being scrapped for the 1939 ones, but only some were just beginning to be put into effect.

The Mobilization Plan for 1939/40 was reasonably well adhered to, but in some cases it was overtaken by the reorganization themselves. For example, the 1. leichte Division (motorisiert) still had the Authorized Strength of a Light Mechanized Division, and did not reflect the new Panzer divisional units already raised and present by 1.09.1939, such as the Headquarters, Motorized Infantry Brigade, or the Armored Signal Battalion.

Although the new “Sonder” KStN dated 1.09.1939 foresaw the main battle tanks as being the Pz-III and Pz-IV, (the Pz-II being relegated to reconnaissance duties, and the Pz-I being officially obsolete), production was not able to meet the demand. Some of this gap was filled with the Czech-manufactured LTM 35 and LTM 38. Not one single mechanized division was equipped with its authorized quota of Pz-III or Pz-IV. Besides doing without, or substituting obsolete Pz-I, the Germans applied various remedies at the organizational level also. The optimistic “Sonder” KStN of 1939 were not issued to all units by any means, and most retaining the older versions.

Production of the Mannschaftstransportwagen (MTW, i.e. armored personnel carrier, later redesignated as Schützenpanzerwagen (SPW), suffered from the same delays that the main battle tanks experienced. The 1st Panzer Division was the only formation equipped with the MTW in the 1939 Polish Campaign. Although it was available in limited numbers, only some of the infantry companies received these invaluable vehicles, while the rest of the companies remained truck-equipped.

KStN applying to the 1939 Panzer Divisions included various vehicles not yet in production, or not yet available in sufficient quantities. The armored radio cars (Sd.Kfz. 260 and 261), although scheduled for

production and even included in the KStN, had not yet even begun to come off the production lines; they were substituted by motor vehicles. The Pz-III (Sd.Kfz. 141), the Pz-IV (Sd.Kfz. 161), the Pz-Bef-III (Sd.Kfz. 266, 267, and 268), the armored command car (Sd.Kfz. 247), and as mentioned, the armored halftrack (Sd.Kfz. 251), etc., suffered from production bottlenecks, or incorrect planning, and were only available in limited quantities.

Neither soft-skinned motor vehicles nor other equipment was never produced by Germany in sufficient numbers to satisfy the needs of the tables of organization. Indeed, it is doubtful if any mechanized unit ever had the exact number and certainly not all the types of vehicles and equipment prescribed by the KStN.

The war diaries of Halder, Chief-of-Staff of the OKH from 1939 – 1942 (*OKH* = German Army High Command), and the official war diaries of the OKW (*OKW* = German Armed Forces High Command), are both full of remarks about the serious lack of equipment, specialist personnel, and vehicles of all sorts, including armored vehicles.

The four motorized infantry divisions all belonged to the 1st Wave (peacetime) formations of the German Army.

This book draws primarily on German tables of organization (KStN) and various orders of battle. The published material contained in the sources and references section indicates publications which were consulted, (although not necessarily used), and is basically meant to assist the reader in familiarizing himself with the subject of the German mechanized divisions of the period.

In a project as immense as this one, it is necessary to rely upon the direct assistance of others. I would like to mention the following for their continuing assistance: Mr. Thomas L. Jentz; Herr Kurt Gätzschmann; Herr Adolf Schönefeld; Mr. William Russ; Herr Brün Meyer. To all of them, my continuing thanks.

The author apologizes for any mistakes that have happened during this process, (they are only my own), and welcomes critical comments and suggestions. Should any reader possess more founded information, or even the original documents thereto, I would appreciate hearing from them, so that in a future edition, the corresponding corrections can be inserted for the benefit of all.

## Preface to the Third Edition

This third edition has again been thoroughly revised, amended, and updated. It now includes the divisional support services as well as the supply trains of the all units and headquarters. Text (originally done on an IBM Composer), layout, and the drawings (originally done by hand), have been redone on computer. New units have been added.

I wish to thank the many readers around the world who have continuously responded to my request to provide addition, corrections and new information, as well as all those who have written and encouraged me to continue this work. If I have not already done so personally, thank you for your patience, support, and encouragement.

## HOW TO READ THE CHARTS

Dates are indicated in the following manner: Day.Month.Year. (Thus 1.09.1939 is the 1st Day of September 1939).

The ordinator for numbers in German is the dot (“.”). Where German units are referred to in their original German designation, this practice has been followed. E.g. *14. Panzer-Division* is the German way of designating the 14th Armored Division.

The Germans normally referred to the large formations and the smallest units with an ordinator (i.e. armies, corps, divisions, brigades, and regimental battalions, as well as companies and platoons), whereas army groups, regiments and independent battalions were referred to in the reverse order. I.e. *Heeresgruppe Mitte, Artillerie-Regiment 103 (mot)*, or *Panzer-Abteilung 33*. To facilitate the location of the various units and to present a uniform system of identification, all units have the identifying numbers indicated first in this work. However, Army Groups, having names or letters – as opposed to numbers – have their designations indicated last.

Numbers in German can be confusing to Anglo-Saxons, as the decimal point becomes a decimal comma:

*German: 10,5*      *English: 10.5 = (ten and a half)*

Similarly, the comma used to separate thousands is also reversed:

*German: 10.000*      *English: 10,000 = (ten thousand)*

Where using German designations, the German practice has been followed (i.e.: *3,7cm Pak*). Otherwise, the English usage prevails: (i.e. 37mm antitank gun), using the millimeter system instead of the German WW II system based on centimeters.

Military motor vehicles and armored fighting vehicles (AFV) have a number behind them in brackets. This number refers to either the German model number (either *Kfz.* = *Kraftfahrzeug*, or to *Sd. Kfz.* = *Sonder Kraftfahrzeug*); or to the tonnage of the carrier. For civilian-type personnel and load carriers without a special number, the engine size or the weight classification is indicated instead.

E.g.: truck (3-ton) refers to a cross-country (all-wheel-drive) load-carrier with a 3-ton load factor. Truck (medium) refers to a civilian (rear-axle-driven) load carrier with a load factor of between 3 to 4.4 tons. Halftrack (7) refers to the 8-ton halftrack (*Zugkraftwagen*) with the *Sd.Kfz.* number 7. Car (2) refers to the light personnel carrier with the *Kfz.* number 2. Etc. Etc. The reader is referred to the sections on vehicles in the back of this book.

Van is a load carrier with a closed, hard body, (usually of wood), used for office, maintenance, and communications work. Truck is a load carrier having an open bed, which could be fitted with a tarpaulin stretched over tubular metal or wooden hoops.

The diagrams are based on reproductions of German organizational symbols of the period.

The text beneath each diagram has been used to clarify it, and to give details about composition and the amounts of sub-units. It breaks down the KStN, giving numbers and date of issue. KStN that are no longer available are marked thus: \*)

The vehicles or items indicated behind the unit being described indicate the amounts in one of these units. E.g.:

3 Lt Tele Sect: 1 car (2), means that the three light telephone sections each have one light communications vehicle (*Kfz.* 2).

In some cases, sections do not have their own vehicles, or several sections share a vehicle. In these two cases, this is indicated in the text. E.g.:

1 Mortar Section: rides with one of the infantry squad's vehicles, or,  
2 Pack Radio Sect: ride together in one truck (2-ton).

The designation “Trains” includes all the administrative, supply, rations, and baggage elements of the corresponding unit. Although maintenance sections and detachments are included under this designation, where present, they have been presented separately for clarity.

TABLES OF ORGANIZATION – *KRIEGSTÄRKENACHWEISUNGEN*

German unit organizations were based on tables of organization, (*Kriegsstärkenachweisungen* – KStN). Every unit raised had them, and all orders raising units indicated the corresponding KStN numbers and dates which applied for them. These orders also indicated any modifications that might apply at the time.

The Germans did not necessarily issue their KStN on the dates indicated on them, and it is highly unlikely that units conformed to the KStN on their issue dates. The KStN could be distributed before or after (retroactively to) the issue date. The issue date merely referred to a specific deadline upon which the KStN was to become effective. Standard KStN were always dated on the 1st of the month. Provisional KStN were dated any other day of the month. These provisional KStN, (issued to test new organizations and changes to be promulgated), were then replaced by the official, standard KStN when ready. Sometimes, these provisional KStN remained in force and in effect became the standard KStN. In such cases, a ‘standard’ KStN (with an issue date on the 1st of the month), was not issued at all.

As new KStN appeared, the old ones were supposed to be destroyed in the field. The bombing and the ensuing fire caused the destruction of the Potsdam military archives in 1945, which means that only portions of the KStN remain today.

KStN could be modified (changed) by General Army Memorandums (AHM – *Allgemeine Heeresmitteilungen*) and also by orders issued by the various arms inspectorates or higher headquarters. These agencies continually changed and modified the KStN, adding a vehicle here, deleting a soldier or three there, or making other modifications.

The KStN are identified by their original issue date in this book. Such changes as made by the orders mentioned above have been incorporated, but the dates of and authorizations for these changes have not been indicated.

The Germans occasionally published lists with valid KStN, approximately once a year. Some of the KStN indicated on these lists were

never published, or they were issued, but with a remark that they were not to be implemented until further notification, (or specific orders), which, in some cases, was rarely, if ever, forthcoming. Some KStN existed only a short time, never appearing on these validity lists, (either cancelled, never authorized, or superseded).

In other cases, validity lists did not even reflect all KStN that existed at the time. Special Annex 8 of the 1939/40 Mobilization Orders was the list of all valid KStN that applied for mobilization. It did not list any of the light mechanized division KStN. The validity list of 15.10.1940 did, although there were by then no longer any leichte Division (motorisiert) to apply them to.

KStN and changes became valid when authorized by higher headquarters and then applied immediately to unit strength reports. Internal reorganizations of the units were not made until the indicated units were able to implement them. This might mean having to wait until the units could be withdrawn from combat and having time for training and administrative matters. Units to be issued with new and particularly complicated equipment were withdrawn to training grounds, transferring most of their old equipment to other units upon departure. A new unit was normally raised, trained, and equipped at one of the training grounds and then sent to the front, where normally, (but not always necessarily immediately), it joined its parent unit or formation.

The author has extrapolated the missing KStN from other KStN, which could be either contemporary and similar, or of the same KStN of later and/or earlier dates. The KStN number of the unit being defined in this case has an \*) behind it. These educated guesses are also based on what information could be gleaned from orders of battle, unit histories (where available), unit strength reports, and German tactical doctrine manuals of the period.

**It is important to emphasize that KStN indicated the maximum authorized organization. In many cases, they represented an ideal organization which in reality was not achieved.**



The symbols in this book are based on the official German handbook of military symbols (H.Dv. 272) of 1938 – with amendments of the symbols as used in the organizational charts (Besondere Anlage 8 of the Mobilization Plans of 1939/1940). Where symbols in the latter are at variance with the former, those symbols of the organizational charts have been used.

In German organizational charts (and, as reflected in this book), the headquarters symbol represents two purposes. First, it indicated the size, function, and mobility of the unit. And, second, it also indicated the headquarters of that echelon itself. I.e., there was no separate symbol for this echelon's headquarters. For all headquarters units with (and sometimes important units without) separate KStN, the corresponding symbols were placed to the right of the echelon's symbol. The same applied to those units that were directly assigned to the echelon's headquarters.

The different functions and mobility additions were used to enhance the echelon's symbol to indicate a specific purpose. Company-sized units and sub-units symbols were also modified in a similar fashion.

An interesting feature of company and sub-unit symbols is that their size and shape dimensions could be altered to fit the diagram being depicted with them. Several infantry companies, for example, were placed side-by-side, elongated upwards, (so that all weapons symbols could fit within), and only the left-hand company had the thickened edge used to indicate its size (more of this below). The variations in size and shape followed the original configuration, so that the basic symbol was still recognizable as such.

The symbols were intended to be mnemonic. The headquarters symbols reflected the units' pennants used on vehicles or the standards themselves. (These flags and pennants were of different colors to represent the various combat arms, and usually had a number, letter, and/or heraldic symbol superimposed upon them). Hence, any German looking at one of these symbols could immediately recognize the unit type being depicted. The colors in real life were substituted by the unit function and mobility modifiers above and below the symbols. In addition, a simplified version of the organizational symbols was, for example, painted on unit vehicles.

The mobility of the unit was also quickly recognizable. The two small circles ('wheels') underneath a symbols identified the unit as being motorized. In case these wheels were over the symbol (applied only to artillery-type units), this indicated that the unit was motorized by half-tracked prime movers. Elongated ovals ('tracks') applied underneath the symbol meant that the unit was self-propelled. A wheel and a track symbol indicated a halftracked armored vehicle.

Although the official handbook indicated that armored infantry units should have the halftrack symbol underneath them instead of the motorized symbol, this practice was not yet followed in most organizational charts at that time. The diagrams in this book reflect this usage.

The lozenge symbol represented armor. All tank units used this symbol. It was shaped to reflect World War I tanks, and hence provided a good memory assist.

Aside from a very few specialized symbols, which were quickly memorized, all company-sized and smaller unit symbols tended to reflect the units' function or at least their main weapon. In most cases, a unit too difficult to depict easily was instead represented by a box with a corresponding abbreviation inside. In case it belonged to a particular arm, the arms symbol could be placed on top of or within this box. Where various modifiers applied, these were all added to the symbol.

Company-sized units had, somewhere within their symbol, a thickened part, usually a side. The only exception found was the Bakery Company, which merely had the symbol representing a loaf of bread.

Excluded from this were the firing artillery (tube, rocket-launcher, and anti-aircraft) batteries. There, the weapon symbol itself in firing batteries (usually with the number of guns underneath) indicating a battery. (Firing artillery in units smaller than battery size were depicted on a smaller scale). None-firing batteries of the artillery arm followed the normal form of thickening a portion of the symbol to indicate their size. Infantry-type artillery (anti-aircraft and infantry gun) and well as machine gun companies followed the normal practice, the weapon symbols representing these types of companies had the upright stems thickened accordingly.

Where several columns, platoons, or detachments were gathered under a company headquarters, (such as a heavy company) – and each of these sub-units had its own KStN – these symbols were placed side-by-side and had a company echelon symbol placed over them.

The Germans numbered their units on organizational charts from the right. I.e., the first company was on the far right, and the last company was on the far left. The same applied to battalions and regiments.

Units smaller than companies appeared on organizational charts only if they had their own KStN. Exceptions occurred, particularly if headquarters sub-units had specialized equipment. They were depicted on a smaller scale than company-sized units.

*Staffel* (Detachment) A unit of varying size with several components under a headquarters section, these components could be from section to platoon size. Often this was merely an administrative grouping, and the components were distributed to other sub-units in combat. It could either have its own small headquarters section, or one of the components' leaders could carry out a dual function.

*Kolonne* (Column) An independent transportation unit, varying from company to platoon size, transporting equipment or supplies such as a bridge column (which in fact did not actually built the bridge it was transporting), or even as an light 'infantry' column (which consisted of a set number of horse-drawn vehicles capable of transporting a fixed tonnage).

*Zug* (Platoon) An independent unit or the typical main sub-division of companies and batteries. Usually, the 1st and 2nd platoons in each company-sized unit, and also of independent platoons, were lead by a lieutenant, while the other platoons were headed by a senior NCO.

*Trupp* (lit. Troop; Section) A small unit, equipped with specialized equipment; it could also be part of the designation for a headquarters echelon unit.

The units indicated below were not depicted as separate symbols.

*Halb-Zug* (lit.: Half-Platoon) Some platoons, for example HMG Platoons, could be divided into two parts.

*Gruppe* (Squad, Section) This was normally the smallest sub-unit that existed in the German Army. In this book, the word "Squad" has only been used for infantry and reconnaissance infantry units. All other units of this size have been designated as "Sections".

*Halb-Gruppe* (lit. Half-Squad, i.e. Team) In the case of infantry and reconnaissance units, squads could be broken down into two parts. Infantry and reconnaissance squads were built up around the squad LMG. Where only one LMG was provided, the LMG team provided cover while the other team was the movement element. Where two LMG were available, the teams covered each other in turns. Reconnaissance teams, on the other hand, were trained to work independently, although they too could function as a squad.

SIZE, FUNCTION, MOBILITY

LUFTWAFFE GROUND COMBAT UNITS

--	--	--	--	--	--	--	--	--	--	--	--













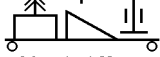









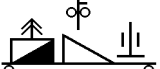















WEAPON SYMBOLS

--	--	--	--	--	--	--	--	--	--	--	--













































INFANTRY UNITS AND MOUNTAIN UNITS

ENGINEER UNITS













MOBILE TROOPS

 Motorized Infantry Platoon	 Motorized Infantry Company	 Motorized Machine Gun Company	 Motorized Heavy Company (typical example)	 Motorized Engineer Platoon	 Motorized Infantry Gun Platoon	 Motorized Mortar Platoon	 Motorized Anti-Tank Company	 Motorcycle Infantry Platoon	 Motorcycle Infantry Company	 Motorcycle Machine Gun Company
 Cavalry Bicycle Recon. Co.	 Motorcycle Recon. Platoon	 Motorcycle Recon. Company	 Motorized Heavy Reconnaissance Company (typical example)	 Motorized Recon. Lt. I.G. Plt.	 Armored Car Platoon	 Armored Car Company	 Mot. Recon. Signal Platoon	 Light Recon. Transport Column		
 Cavalry Platoon	 Cavalry Company	 Cavalry Machine Gun Company	 Cavalry Bicycle Company	 Cavalry Heavy Company	 Cavalry Recon. Platoon	 Cavalry Infantry Gun Platoon	 Cavalry Engineer Platoon	 Cavalry Anti-Tank Platoon	 Cavalry Motorized Heavy Company (typical example)	 Cavalry Signal Platoon
 Light Tank Platoon	 Light Tank Company	 Light Tank Company a	 Medium Tank Company	 Headquarters Company	 Reserve Tank Detachment	 Tank Maintenance Platoon	 Tank Maintenance Company	 Armored Signal Platoon	 Light Panzer Transport Column	





































ARTILLERY UNITS

 75mm Field Gun Battery	 75mm Mtn. Gun Battery (GK 15)	 105mm Mtn. Howitzer Battery	 75mm Field Gun Battery (FK 16nA)	 75mm Cav. Gun Battery (FK 16nA)	 75mm Field Gun Battery (FK 18)	 105mm Field Howitzer Battery	 105mm Field Howitzer Bty. (l. FH 16)	 105mm Field Howitzer Bty. (l. FH 18)	 105mm Gun Battery	 105mm Gun Battery (K 17)	 105mm Gun Battery (K 18)
 150mm Gun Battery (K 16)	 150mm Gun Battery (K 18)	 150mm Gun Battery (K 39)	 150mm Gun Battery (How. Base)	 210mm Gun Battery (K 12)	 210mm Gun Battery (K 38)	 210mm Gun Battery (K 39)	 240mm Gun Battery	 240mm Gun Battery (K 3)	 Heavy Field Howitzer Battery	 150mm Field Howitzer Bty. (s. lg. FH 13)	 150mm Field Howitzer Bty. (sFH 18)
 210mm Howitzer Bty. (lange Mörser)	 210mm Howitzer Bty. (M 18)	 240mm Howitzer Bty. (H 39)	 305mm Howitzer Battery		 105mm Rocket Launcher Bty. (Nb. W. 35)	 Decontamination Battery			 Headquarters Battery	 Motorized Headquarters Battery	 Hqs. Bty. Art. Obs. Battalion
 Motorized Calibration Detachment	 Mountain Calibration Detachment	 Calibration Platoon	 Weather Detachment	 Motorized Weather Platoon	 Calibration Battery	 Sound-Ranging Battery	 Flash-Ranging Battery	 Balloon Detachment	 Motorized Balloon Battery	 Artillery Transport Column (mot)	 Artillery Motor Towing Detachment

SIGNAL UNITS

 Motorized Propaganda Company	 Motorized Signal Company	 Motorized Telephone Company	 Mountain Telephone Company	 Telephone Construction Company	 Wire Construction Company	 Telephone Operations Company	 Motorized Radio Company	 Motorized Interception Company	 Armored Signal Company	 Armored Radio Company	 Light Signal Transport Column (mot)
---	---	--	---	---	--	---	---	---	---	--	--

REAR ECHELON UNITS

 Horse-Drawn Transport Column (15t)	 Horse-Drawn Transport Column (30t)	 Horse-Drawn Transport Column (60t)	 Motorized Transport Column (30t)	 Motorized Transport Column (60t)	 Motorized Supply Company	 Motorized P.O.L. Col. (25cbm)	 Motorized P.O.L. Col. (50cbm)	 Motorized Water Tanker Col. (60cbm)	 Motorized Maintenance Platoon	 Motorized Maintenance Company	 Park
 Carrier Pigeon Dovecot	 Motorized Mapping Detachment	 Motorized Printing Detachment	 Casualty Transport Company	 Casualty Field Hospital	 Light Casualty Field Hospital	 Field Hospital	 Medical Company	 Motorized Ambulance Platoon	 Veterinary Company	 Veterinary Hospital	 Mot. Horse Transport Column
 Motorized Bakery Company	 Motorized Butchery Platoon	 Commissary Detachment	 Motorized Field Post Detachment	 Motorized Military Police Platoon	 Motorized Military Police Company	 Secret Field Police Detachment	 Survey Detachment (motorized)	 Survey Company (motorized)	 Survey Printing Det. (mot)	 Labor or Construction Company	 Armored Train

<i>Abbr.</i>	<i>German</i>	<i>English</i>	<i>Abbr.</i>	<i>German</i>	<i>English</i>
		<b>A</b>			
AA	–	anti-aircraft	kl	klein	small, light
A.A.	Aufklärungs-Abteilung	reconnaissance battalion	Kol	Kolonne	Column
Abt	Abteilung	Battalion echelon unit	Kp	Kompanie	Company
–	Abschnitt	Sector	Krad	Kraftrad	motorcycle
AFV	–	armored fighting vehicle	KStN	Kriegstärkenachweisung	Table of Organization
Agr	Armeegruppe	temporary group of several Corps	kz	kurz	short
Ammo	–	ammunition			<b>L</b>
–	Amt	office / department / section	l, le, lei	leicht	light
Armd	–	armored	–	Lehr	demonstration
–	Armee	Army	Ig	lang	long
AK	Armeekorps	Army Corps	Li	Lichtmess	flash ranging
AT	–	anti-tank	LMG	–	light machine gun
ATG	–	anti-tank gun	lt	–	light
ATR	–	anti-tank rifle	Lw, Ldw	Landwehr	Militia / National Guard
Arko	Artillerie Kommandeur	Artillery Commander	L, Lw	Luftwaffe	German Air Force
Aufkl	Aufklärungs-	reconnaissance			<b>M</b>
Ausf	Ausführung	mark / model / type	M, Mörs	Mörser	heavy howitzer
		<b>B</b>	m	mittler	medium
Battr	Batterie	Battery (Company echelon unit)	mcl (w/sc)	–	motorcycle (with sidecar)
Btl, Batl	Bataillon	Battalion	med	–	medium
Bb, Beob	Beobachtung	observation	MG	Maschinengewehr	machine gun
Bef-Pz	Befehlspanzer	command tank	mot	motorisiert	motorized
Bn	–	Battalion	mot S	mot. Selbstfahrlafette	motorized self-propelled carriage
Brig	Brigade	Brigade	mot Z	motorisierter Zug	motorized prime mover
Bty	–	Battery (Company echelon unit)	MTW	Mannschaftstransportwagen	armored personnel carrier
		<b>C</b>			<b>N</b>
cc	–	cross-country	Nachr	Nachrichten-	signal
Co	–	Company	Nbl	Nebel	smoke
CO	–	commanding officer	Nbl W	Nebelwerfer	rocket launcher
Col	–	(unit) Column	NCO	–	Non-Commissioned Officer
Col	–	(rank) colonel			<b>O</b>
		<b>D</b>	Ob	Oberbefehlshaber	Commander-in-Chief
Det	–	Detachment	Off	–	Officer
–	Dienst(e)-	service(s)	OKH	Oberkommando des Heeres	Army High Command
Div	Division	Division	OKW	Oberkommando der Wehrmacht	Armed Forces High Command
		<b>E</b>	ops	–	operations
(E)	Eisenbahn	railroad			<b>P</b>
EM	–	Enlisted Man	Pak	Panzerabwehrkanone	(weapon) anti-tank gun
Engr	–	Engineer	Pz Abw	Panzer-Abwehr	(unit) anti-tank
		<b>F</b>	Pi, Pion	Pionier	Engineer
F, Fest	Festung	Fortress	Plt	–	Platoon
FH	Feldhaubitze	field howitzer (gun-howitzer)	Prop	Propaganda	propaganda
FK	Feldkanone	field gun	Pz, Panz	Panzer	tank, armor
Fla	Fliegerabwehr	anti-aircraft			<b>R</b>
Flak	Flugabwehrkanone	(weapon) anti-aircraft gun	Recon	–	reconnaissance
Flak	Flugabwehr	(unit) anti-aircraft defense	Rgt	Regiment	Regiment
–	Führungsstab z.b.V.	Headquarters for Special			<b>S</b>
Purposes			s, schw	schwer	heavy
		<b>G</b>	S	Schützen	mechanized infantry (lit.: riflemen)
G, Gesch	Geschütz	gun (cannon)	Sch	Schallmess	sound ranging
Geb	Gebirgs-	mountain	Schw	Schwadron	Company echelon unit (lit.: squadron)
Gen	–	(rank) general	Sd	sonder	special
gem	gemischt(e)(er)-	mixed	Sd Kfz	Sonder-Kraftfahrzeug	special military motor vehicle
GHQ	–	General Headquarters	Sect	–	Section
GK	Gebirgskanone	mountain gun	SMG	–	sub machine gun
Gen Kdo	General Kommando	Corps echelon Command	SP, SP'd	–	self-propelled
gp, gep	gepanzert	armored	Sdq	–	Squad
Gr	Gruppe	Group	Sqdn	–	Squadron (Company echelon unit)
Grz	Grenz	Border	SS	Waffen-SS	Nazi Party military arm
Grz Schtz	Grenzschutz	Border Protection	SS-VT	SS-Verfügungs-Truppen	SS combat troops (Waffen-SS)
Grz Tr	Grenztruppen	Border Troops	ss, sw	schwerste	super heavy
Grz Wa	Grenzwacht	Border Guards	St, Stb	Stab	headquarters
GSO	(Beamte)	Government Service Official			<b>T</b>
		<b>H</b>	(t)	tschechisch	Czechoslovakian
H, Haub	Haubitze	howitzer	tele	–	telephone
H Tr	Heerestruppen	GHQ Troops	Tr	Trupp/Trupps	(unit) Section (lit.: Troop)/Sections
Harko	Höhere Artillerie Kommandeur	Higher Artillery Commander	Tr	Truppen	(general designation ) Troops
HE	–	high explosive			<b>V</b>
Hgr	Heeresgruppe	Army Group	Verb	Verband	formation
HMG	–	heavy machine gun	verl	verlastet	truck-borne / portee
Hqs	–	headquarters	Versorg	Versorgungs-	support
hvy	–	heavy	Verpfl A	Verpflegungsamt	rations administration section
		<b>I</b>			<b>W</b>
IG	Infanterie-Geschütze	infantry gun	w/ (w/o)	–	with (without)
I, Inf	Infanterie	Infantry	–	Welle	mobilization group (lit.: wave)
		<b>K</b>	–	Werkstatt	maintenance (lit.: workshop)
K, Kan	Kanone	gun	Wfr	Werfer	(rocket-, grenade-) launcher
Kav	Kavallerie	Cavalry	WK	Wehrkreis	Military District
Kdo	Kommando	Command			<b>Z</b>
Kdr	Kommandeur	commander	zbV	zur besonderer Verwendung	for special purposes / use
Kdt	Kommandant	commandant	Zug	–	(unit) Platoon
			Zug	–	(vehicle) prime mover

## ORDER OF BATTLE

Army Group	Army	Corps	Formations and Units	NOTES:
<b>NORD</b> 73. Infanterie-Division 206. Infanterie-Division 208. Infanterie-Division  <div style="border: 1px solid black; padding: 2px; width: fit-content;">             OKH Reserves at Heeresgruppe Nord              3. Panzer-Division           </div>	<b>4. Armee</b> 23. Infanterie-Division 218. Infanterie-Division	2. Grenzschutz-Abschnitts-Kdo. <sup>1</sup>	2. Grenzschutz-Abschnitt 52. Grenzschutz-Abschnitt	<b>1.</b> The Brigade Netze comprised the 12. Grenzschutz-Abschnitt and 22. Grenzschutz-Abschnitt, of the 2. Grenzschutz-Abschnitts-Kdo.  <b>2.</b> The 20. Infanterie-Division (mot) was reinforced by 2 infantry battalions and 1 artillery battalion from the 12. Infanterie-Division.  <b>3.</b> The Gruppe Danzig (also known as the Brigade Eberhard) had 2 regiments Danzig "Landespolizei" and 1 artillery battalion.  <b>4.</b> The Festung Lötzen had an approximate strength of one "Landwehr" division.  <b>5.</b> The Brigade Goldap comprised the fortress troops of Königsberg, the 51. Grenzschutz-Abschnitt, 4 battalions of "Landeschützen", 1 artillery battalion, 1 anti-tank battalion, 1 engineer battalion, and misc. other units.  <b>6.</b> The 16. Infanterie-Regiment was an air-landing unit, detached from the 22. Infanterie-Division.  <b>7.</b> The 4th Welle infantry divisions were released by the OKH on 3.09.1939 as follows: 251. to 5. Armee 253. to 5. Armee 254. to 5. Armee 260. to Gen. Kdo. Grz. Tr. Oberrhein 262. to Gen. Kdo. Grz. Tr. Oberrhein 263. to 5. Armee 267. to 5. Armee 268. to 1. Armee 269. to 5. Armee  [The 255. and 256. Infanterie-Divisions (the remaining 4th Welle formations), although OKH Reserves, were not really ready at this time, and were not released at all.]  <b>8.</b> The 76. Infanterie-Division was truck-borne by means of a motor transportation regiment. On 1.09.1939, this division was released by the OKH to Heeresgruppe C, and was still en-route at this time.  <b>9.</b> These divisions were released on 1.09.1939 by the OKH, and were still en-route at this time.  <b>Generalkommando der Grenztruppen</b> Corps echelon command of the Border Troops  <b>Grenzschutz-Abschnitts-Kommando</b> Corps or Divisional echelon of the Border Guards  <b>Grenzschutz-Abschnitt</b> Regimental echelon of the Border Guards
		12. Grenzschutz-Abschnitts-Kdo.	3. Grenzschutz-Abschnitt 13. Grenzschutz-Abschnitt 23. Grenzschutz-Abschnitt Festung Küstrin	
		III. Armeekorps	50. Infanterie-Division Brigade Netze <sup>1</sup>	
		II. Armeekorps	3. Infanterie-Division 32. Infanterie-Division	
		XIX. Armeekorps (motorisiert)	2. Infanterie-Division (mot) <sup>2</sup> 20. Infanterie-Division (mot) <sup>2</sup> 3. Panzer-Division	
		1. Grenzschutz-Abschnitts-Kdo.	207. Infanterie-Division 32. Grenzschutz-Abschnitt 42. Grenzschutz-Abschnitt	
	<b>3. Armee</b> 217. Infanterie-Division	15. Grenzschutz-Abschnitts-Kdo.	1. Grenzschutz-Abschnitt 21. Grenzschutz-Abschnitt	
		Gruppe Danzig <sup>3</sup> Gruppe Oberst Medem		
		XXI. Armeekorps	21. Infanterie-Division 228. Infanterie-Division 11. Grenzschutz-Abschnitt	
		I. Armeekorps	11. Infanterie-Division 61. Infanterie-Division Panzerverband Kempf	
Führungsstab z.b.V. (Stab Wodrig)		1. Infanterie-Division 12. Infanterie-Division <sup>2</sup> 31. Grenzschutz-Abschnitt		
Gruppe Brand		1. Kavallerie-Brigade  Lötzen Festung <sup>4</sup> Brigade Goldap <sup>5</sup> 41. Grenzschutz-Abschnitt 61. Grenzschutz-Abschnitt		
<b>SÜD</b> 16. Infanterie-Regiment <sup>6</sup> 252. Infanterie-Division <sup>10</sup> 257. Infanterie-Division <sup>10</sup> 258. Infanterie-Division <sup>10</sup>  VII. Armeekorps - 27. Infanterie-Division - 68. Infanterie-Division  XXII. Armeekorps - 62. Infanterie-Division - 213. Infanterie-Division - 221. Infanterie-Division  <div style="border: 1px solid black; padding: 2px; width: fit-content;">             OKH Reserves at Heeresgruppe Süd              56. Infanterie-Division              57. Infanterie-Division           </div>	<b>8. Armee</b> 30. Infanterie-Division	13. Grenzschutz-Abschnitts-Kdo.	108. Grenzschutz-Abschnitt 118. Grenzschutz-Abschnitt 138. Stellungen-Abschnitt 148. Stellungen-Abschnitt	
		14. Grenzschutz-Abschnitts-Kdo.	88. Grenzschutz-Abschnitt 98. Grenzschutz-Abschnitt 126. Stellungen-Abschnitt 183. Landwehr-Regiment	
		X. Armeekorps	24. Infanterie-Division	
		XIII. Armeekorps	10. Infanterie-Division 17. Infanterie-Division Leibstandarte-SS Adolf Hitler	
	<b>10. Armee</b> 1. leichte Division (mot) 2. leichte Division (mot)	XI. Armeekorps	13. Infanterie-Division (mot) 29. Infanterie-Division (mot)	
		XVI. Armeekorps (motorisiert)	14. Infanterie-Division 31. Infanterie-Division 1. Panzer-Division	
		XIV. Armeekorps (motorisiert)	18. Infanterie-Division 19. Infanterie-Division 4. Panzer-Division	
		IV. Armeekorps	4. Infanterie-Division 46. Infanterie-Division	
		XV. Armeekorps (motorisiert)	3. leichte Division (mot)	
	<b>14. Armee</b> 1. Gebirgs-Division 2. Gebirgs-Division 30. Grenzschutz-Abschnitts-Kdo.	VIII. Armeekorps	8. Infanterie-Division 28. Infanterie-Division 239. Infanterie-Division 5. Panzer-Division SS-Standarte Germania (mot) 3. Grenzschutz-Abschnitts-Kdo.	
XVII. Armeekorps		7. Infanterie-Division 44. Infanterie-Division 45. Infanterie-Division		
XVIII. Armeekorps		3. Gebirgs-Division 4. leichte Division (mot) 2. Panzer-Division		
VI. Armeekorps		16. Grenzschutz-Abschnitt		
<b>C</b> 78. Infanterie-Division <sup>7</sup>  <div style="border: 1px solid black; padding: 2px; width: fit-content;">             OKH Reserves at Heeresgruppe C              251. Infanterie-Division<sup>7</sup>              253. Infanterie-Division<sup>7</sup>              254. Infanterie-Division<sup>7</sup>              255. Infanterie-Division<sup>7</sup>              256. Infanterie-Division<sup>7</sup>              260. Infanterie-Division<sup>7</sup>              262. Infanterie-Division<sup>7</sup>              263. Infanterie-Division<sup>7</sup>              267. Infanterie-Division<sup>7</sup>              268. Infanterie-Division<sup>7</sup>              269. Infanterie-Division<sup>7</sup> </div>	<b>5. Armee</b> 58. Infanterie-Division 87. Infanterie-Division <sup>9</sup>	XXX. Armeekorps	9. Grenzschutz-Abschnitts-Kdo.	
		V. Armeekorps	22. Infanterie-Division <sup>6</sup> 225. Infanterie-Division	
		XXVII. Armeekorps	16. Infanterie-Division 69. Infanterie-Division 211. Infanterie-Division 216. Infanterie-Division	
		Generalkommando der Grenztruppen Eifel	26. Infanterie-Division 86. Infanterie-Division 227. Infanterie-Division Grenzschutz-Abschnitts-Kdo. Trier Grenzschutz-Abschnitts-Kdo. Aachen	
	<b>1. Armee</b> 75. Infanterie-Division <sup>9</sup> 209. Infanterie-Division 214. Infanterie-Division 223. Infanterie-Division 231. Infanterie-Division 246. Infanterie-Division	XII. Armeekorps	15. Infanterie-Division 34. Infanterie-Division 52. Infanterie-Division 79. Infanterie-Division	
		Generalkommando der Grenztruppen Saarpfalz	6. Infanterie-Division 9. Infanterie-Division 36. Infanterie-Division 125. Grenzinfanterie-Regiment 127. Grenzinfanterie-Regiment 129. Grenzinfanterie-Regiment 132. Grenzschutz-Abschnitt 142. Grenzschutz-Abschnitt 152. Grenzschutz-Abschnitt	
		IX. Armeekorps	25. Infanterie-Division 33. Infanterie-Division 71. Infanterie-Division	
	<b>7. Armee</b> 78. Infanterie-Division 212. Infanterie-Division 215. Infanterie-Division	Generalkommando der Grenztruppen Oberrhein	5. Infanterie-Division 14. Landwehr-Division 35. Infanterie-Division SS-Standarte Der Führer (mot)	

## 1. Panzer-Division

Activated 15.10.1935  
 Mobilized 18.08.1939  
 Home Garrison IX Wehrkreis  
 Status on 1.09.1939

Assigned to XVI. Armeekorps (mot), 10. Armee, Heeresgruppe Süd  
 Commanding General Generalmajor (US equivalent is Brigadier General □ )  
 Rudolf Schmidt

## Authorized Strength in accordance with the Mobilization Plan 1939/1940

	Division Total	Division Headquarters <sup>4</sup>	Infantry Brigade	Panzer Brigade	Artillery Regiment	Recon Battalion	Anti-Tank Battalion	Engineer Battalion	Signal Battalion	Support Services
Officers	394	18	87	120	44	26	22	22	13	42
Government Service Officials	115	14	11	22	6	4	3	2	3	50
Non-Commissioned Officers	1,962	26	471	682	156	116	132	83	83	213
Enlisted Men	9,321	107	2,614	2,112	997	607	551	713	323	1,297
<b>Total</b>	<b>11,792</b>	<b>165</b>	<b>3,183</b>	<b>2,936</b>	<b>1,203</b>	<b>753</b>	<b>708</b>	<b>820</b>	<b>422</b>	<b>1,602</b>
Pistols	4,625	50	857	2,181	210	326	267	142	196	396
Rifles	7,249	111	2,292	1,235	993	427	441	678	326	847
Sub-Machine Guns	395	–	8	296	–	62	2	–	27	–
Light Machine Guns <sup>1</sup>	825	–	93	592	12	68	18	27	15	–
Heavy Machine Guns	46	2	42	–	–	2	–	–	–	–
20mm AA Guns	12	–	–	–	–	–	12	–	–	–
37mm AT Guns	48	–	9	–	–	3	36	–	–	–
light (50mm) Mortars	30	–	27	–	–	3	–	–	–	–
heavy (81mm) Mortars	18	–	18	–	–	–	–	–	–	–
light (75mm) Infantry Guns	8	–	6	–	–	2	–	–	–	–
heavy (150mm) Infantry Guns	–	–	–	–	–	–	–	–	–	–
light (105mm) Field Howitzers	24	–	–	–	24	–	–	–	–	–
heavy (105mm) Guns	–	–	–	–	–	–	–	–	–	–
heavy (150mm) Field Howitzers	–	–	–	–	–	–	–	–	–	–
20mm AFV Guns	98	–	–	78	–	20	–	–	–	–
37mm AFV Guns	112	–	–	112	–	–	–	–	–	–
75mm AFV Guns	56	–	–	56	–	–	–	–	–	–
Gun Tanks	246	–	–	246	–	–	–	–	–	–
Other Tanks <sup>2</sup>	85	–	–	78	–	–	–	–	7	–
Armored Cars <sup>3</sup>	90	–	8	–	–	60	2	–	20	–
<b>Total AFV</b>	<b>421</b>	<b>–</b>	<b>8</b>	<b>324</b>	<b>–</b>	<b>60</b>	<b>2</b>	<b>–</b>	<b>27</b>	<b>–</b>
Personnel Carriers	561	11	149	88	104	34	43	43	40	49
Load Carriers	1,402	13	316	296	143	68	91	117	35	323
Motorcycles	691	40	138	138	88	37	32	47	24	34
Motorcycles with sidecars	711	1	355	108	22	82	46	31	3	63
Trailers	83	–	3	26	24	1	12	–	3	14

1) LMG includes those mounted on AFV.

2) Other tanks are command tanks, signal tanks, and MG-equipped tanks.

3) Armored Cars include command armored cars, signal armored cars, MG-equipped armored cars, and gun-equipped armored cars.

4) Including the Headquarters, Panzer Division; the Motorcycle Messenger Platoon; and the Motorized Mapping Detachment.

## Tank Strength on 1.09.1939

Div.	Brig.	Rgt.	Bn.	Tank Companies		Tanks							
				light	medium	Pz-I	Pz-II	Pz/35	Pz/38	Pz-III	Pz-IV	Pz-Bef	Total
1. Pz	1.	1.	I & II	2	1	39	60	–	–	20	28	6	119
		2.	I & II	2	1	54	62	–	–	6	28	6	122

1.09.1939

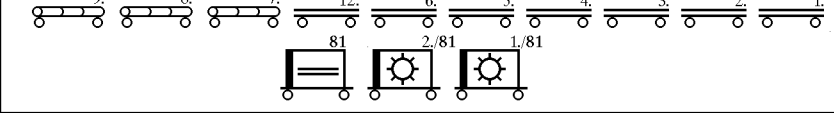
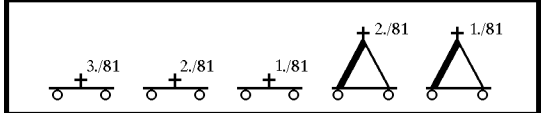
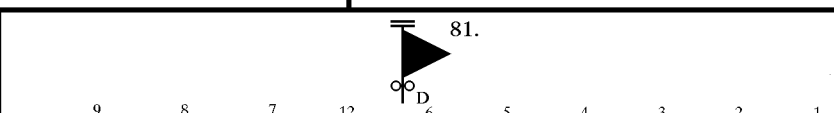
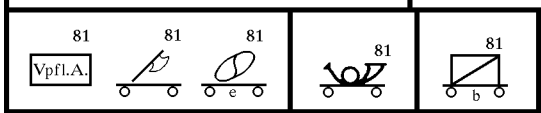
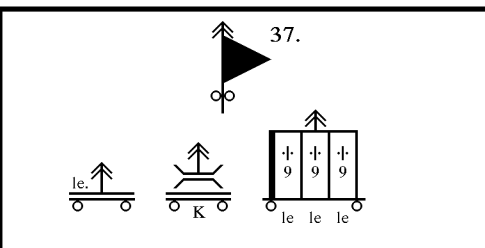
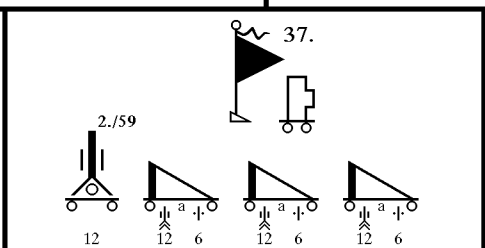
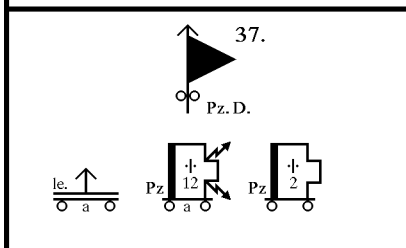
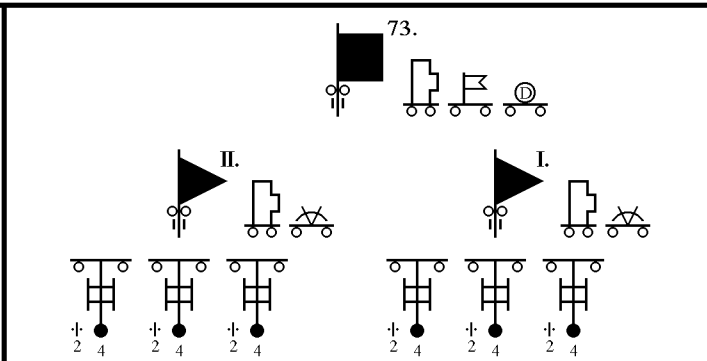
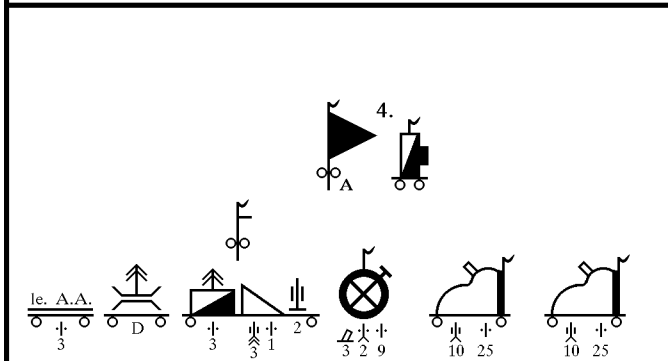
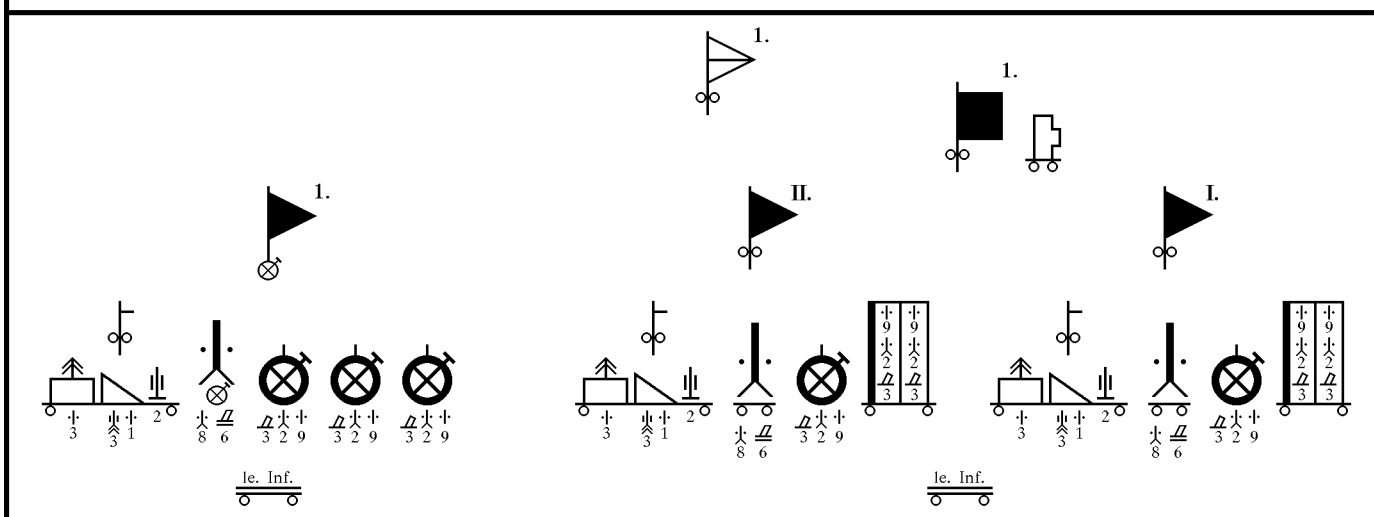
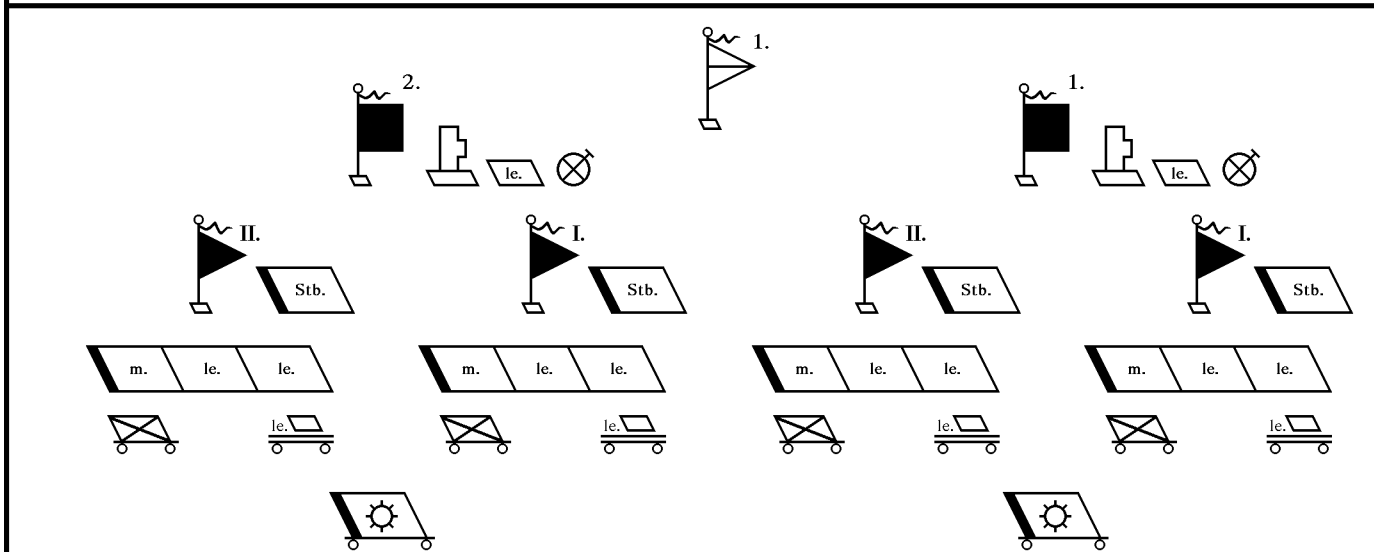
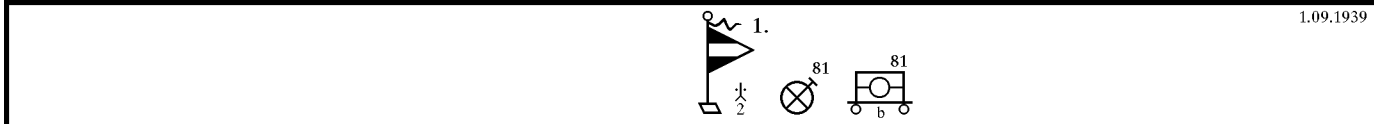

## 2. Panzer-Division

Activated 15.10.1935  
 Mobilized 19.08.1939  
 Home Garrison XVII Wehrkreis  
 Status on 1.09.1939

Assigned to XVIII. Armeekorps, 14. Armee, Heeresgruppe Süd  
 Commanding General Generalleutnant (US equivalent is Major General □ □ )  
 Rudolf Veiel

## Authorized Strength in accordance with the Mobilization Plan 1939/1940

	Division Total	Division Headquarters <sup>4</sup>	Infantry Brigade	Panzer Brigade	Artillery Regiment	Recon Battalion	Anti-Tank Battalion	Engineer Battalion	Signal Battalion	Support Services
Officers	391	18	87	120	45	26	18	22	13	42
Government Service Officials	115	14	11	22	6	4	3	2	3	50
Non-Commissioned Officers	1,932	26	471	682	155	116	103	83	83	213
Enlisted Men	9,172	107	2,614	2,112	1,004	607	395	713	323	1,297
<b>Total</b>	<b>11,610</b>	<b>165</b>	<b>3,183</b>	<b>2,936</b>	<b>1,210</b>	<b>753</b>	<b>519</b>	<b>820</b>	<b>422</b>	<b>1,602</b>
Pistols	4,186	50	857	1,801	214	326	204	142	196	396
Rifles	7,102	111	2,291	1,111	996	427	315	678	326	847
Sub-Machine Guns	435	–	8	336	–	62	2	–	27	–
Light Machine Guns <sup>1</sup>	741	–	93	508	12	68	18	27	15	–
Heavy Machine Guns	46	2	42	–	–	2	–	–	–	–
20mm AA Guns	–	–	–	–	–	–	–	–	–	–
37mm AT Guns	48	–	9	–	–	3	36	–	–	–
light (50mm) Mortars	30	–	27	–	–	3	–	–	–	–
heavy (81mm) Mortars	18	–	18	–	–	–	–	–	–	–
light (75mm) Infantry Guns	8	–	6	–	–	2	–	–	–	–
heavy (150mm) Infantry Guns	–	–	–	–	–	–	–	–	–	–
light (105mm) Field Howitzers	12	–	–	–	12	–	–	–	–	–
heavy (105mm) Guns	4	–	–	–	4	–	–	–	–	–
heavy (150mm) Field Howitzers	8	–	–	–	8	–	–	–	–	–
20mm AFV Guns	158	–	–	138	–	20	–	–	–	–
37mm AFV Guns	20	–	–	20	–	–	–	–	–	–
75mm AFV Guns	24	–	–	24	–	–	–	–	–	–
Gun Tanks	182	–	–	182	–	–	–	–	–	–
Other Tanks <sup>2</sup>	133	–	–	126	–	–	–	–	7	–
Armored Cars <sup>3</sup>	90	–	8	–	–	60	2	–	20	–
<b>Total AFV</b>	<b>425</b>	<b>–</b>	<b>8</b>	<b>328</b>	<b>–</b>	<b>60</b>	<b>2</b>	<b>–</b>	<b>27</b>	<b>–</b>
Personnel Carriers	544	11	149	88	102	34	29	43	40	48
Load Carriers	1,399	13	316	328	144	68	68	117	35	312
Motorcycles	566	40	138	138	86	37	23	47	24	33
Motorcycles with sidecars	703	1	355	108	22	82	40	31	3	61
Trailers	59	–	3	26	12	1	–	–	3	14

1) LMG includes those mounted on AFV.

2) Other tanks are command tanks, signal tanks, and MG-equipped tanks.

3) Armored Cars include command armored cars, signal armored cars, MG-equipped armored cars, and gun-equipped armored cars.

4) Including the Headquarters, Panzer Division; the Motorcycle Messenger Platoon; and the Motorized Mapping Detachment.

## Tank Strength on 1.09.1939

Div.	Brig.	Rgt.	Bn.	Tank Companies		Tanks							
				light	medium	Pz-I	Pz-II	Pz/35	Pz/38	Pz-III	Pz-IV	Pz-Bef	Total
2. Pz	2.	3.	I & II	2	1	62	78	–	–	3	8	9	143
		4.	I & II	2	1	62	77	–	–	3	9	11	142

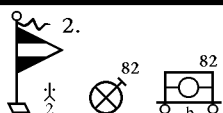

1.09.1939

2. 

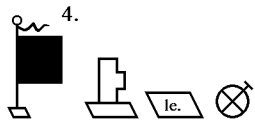
4. 

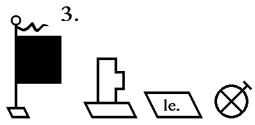
3. 

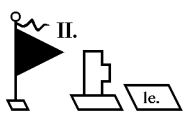
II. 

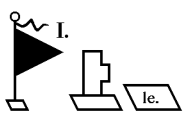
I. 

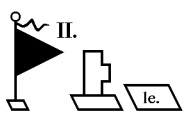
II. 

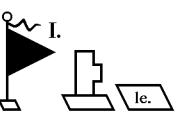
I. 

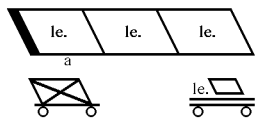
le. 

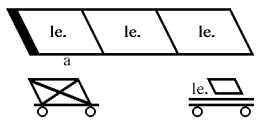
le. 

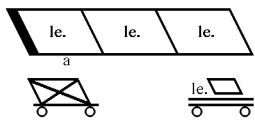
le. 

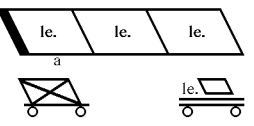
le. 

a 

a 

a 

a 

2. 

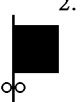
2. 

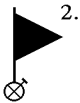
2. 

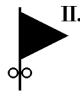
II. 

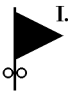
I. 

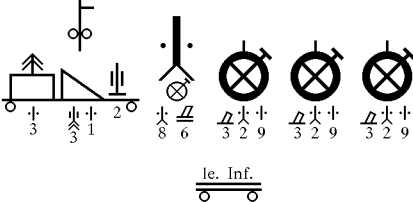
le. Inf. 

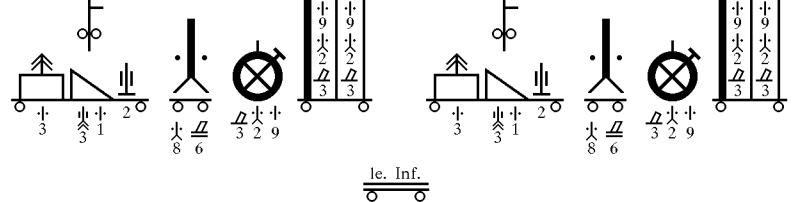
le. Inf. 

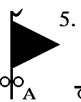
5. 

le. A.A. 

3. 

3. 

3. 

2. 

3. 

6. 

9. 

2. 

9. 

2. 

9. 

3. 

9. 

2. 

9. 

2. 

9. 

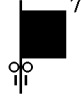
74. 

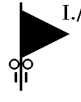
I./110 

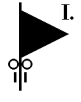
I. 

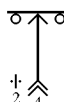
2. 

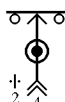
4. 

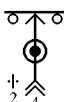
2. 

4. 

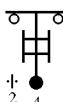
2. 

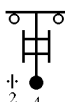
4. 

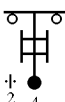
2. 

4. 

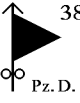
38. 

Pz. D. 

le. 

a 

Pz. 

12 

a 

Pz. 

2 

38. 

le. 

a 

12 

6 

12 

6 

12 

6 

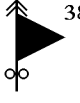
38. 

le. 

K 

le. 

le. 

le. 

82 

82 

82 

Vpfl.A. 

82 

82 

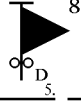
82. 

9 

8 

7 

6 

5 

4 

3 

2 

1 

82 

2/82 

1/82 

3/82 

2/82 

1/82 

2/82 

1/82 

## 3. Panzer-Division

Activated 15.10.1935  
 Mobilized 1.08.1939  
 Home Garrison III Wehrkreis  
 Status on 1.09.1939

Assigned to XIX. Armeekorps (mot), 4. Armee, Heeresgruppe Nord  
 Commanding General Generalleutnant (US equivalent is Major General □ □ )  
 Leo Freiherr von Schweppenburg

## Authorized Strength in accordance with the Mobilization Plan 1939/1940

	Division Total	Division Headquarters <sup>4</sup>	Infantry Brigade	Panzer Brigade	Artillery Regiment	Recon Battalion	Anti-Tank Battalion	Engineer Battalion	Signal Battalion	Support Services
Officers	394	18	87	120	44	26	22	22	13	42
Government Service Officials	115	14	11	22	6	4	3	2	3	50
Non-Commissioned Officers	1,962	26	471	682	156	116	132	83	83	213
Enlisted Men	9,321	107	2,614	2,112	997	607	551	713	323	1,297
<b>Total</b>	<b>11,792</b>	<b>165</b>	<b>3,183</b>	<b>2,936</b>	<b>1,203</b>	<b>753</b>	<b>708</b>	<b>820</b>	<b>422</b>	<b>1,602</b>
Pistols	4,245	50	857	1,801	210	326	267	142	196	396
Rifles	7,225	111	2,291	1,111	993	427	441	678	326	847
Sub-Machine Guns	435	–	8	336	–	62	2	–	27	–
Light Machine Guns <sup>1</sup>	741	–	93	508	12	68	18	27	15	–
Heavy Machine Guns	46	2	42	–	–	2	–	–	–	–
20mm AA Guns	12	–	–	–	–	–	12	–	–	–
37mm AT Guns	48	–	9	–	–	3	36	–	–	–
light (50mm) Mortars	30	–	27	–	–	3	–	–	–	–
heavy (81mm) Mortars	18	–	18	–	–	–	–	–	–	–
light (75mm) Infantry Guns	8	–	6	–	–	2	–	–	–	–
heavy (150mm) Infantry Guns	–	–	–	–	–	–	–	–	–	–
light (105mm) Field Howitzers	24	–	–	–	24	–	–	–	–	–
heavy (105mm) Guns	–	–	–	–	–	–	–	–	–	–
heavy (150mm) Field Howitzers	–	–	–	–	–	–	–	–	–	–
20mm AFV Guns	158	–	–	138	–	20	–	–	–	–
37mm AFV Guns	20	–	–	20	–	–	–	–	–	–
75mm AFV Guns	24	–	–	24	–	–	–	–	–	–
Gun Tanks	182	–	–	182	–	–	–	–	–	–
Other Tanks <sup>2</sup>	133	–	–	126	–	–	–	–	7	–
Armored Cars <sup>3</sup>	90	–	8	–	–	60	2	–	20	–
<b>Total AFV</b>	<b>425</b>	<b>–</b>	<b>8</b>	<b>328</b>	<b>–</b>	<b>60</b>	<b>2</b>	<b>–</b>	<b>27</b>	<b>–</b>
Personnel Carriers	560	11	149	88	104	34	43	43	40	48
Load Carriers	1,421	13	316	328	143	68	91	117	35	312
Motorcycles	577	40	138	138	88	37	32	47	24	33
Motorcycles with sidecars	709	1	355	108	22	82	46	31	3	61
Trailers	83	–	3	26	24	1	–	–	3	14

1) LMG includes those mounted on AFV.

2) Other tanks are command tanks, signal tanks, and MG-equipped tanks.



3) Armored Cars include command armored cars, signal armored cars, MG-equipped armored cars, and gun-equipped armored cars.









4) Including the Headquarters, Panzer Division; the Motorcycle Messenger Platoon; and the Motorized Mapping Detachment.













## Tank Strength on 1.09.1939













Div.	Brig.	Rgt.	Bn.	Tank Companies		Tanks							
				light	medium	Pz-I	Pz-II	Pz/35	Pz/38	Pz-III	Pz-IV	Pz-Bef	Total
3. Pz	3.	5.	I & II	2	1	63	77	–	–	3	9	8	143
			6. I & II	2	1	59	79	–	–	3	9	8	141









1.09.1939



3.  3.  83  83



6.     3.  3. 5.    



II.    I.    II.    I.   











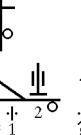

           

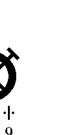

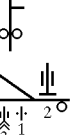

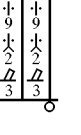

3.  3.  3. 

3.  II.  I. 





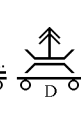
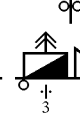
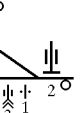

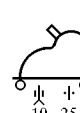





le. Inf. le. Inf.

3.  



le. A.A.      

$\frac{1}{3}$   $\frac{1}{3}$   $\frac{1}{3}$   $\frac{1}{3}$   $\frac{1}{3}$   $\frac{1}{3}$   $\frac{1}{10}$   $\frac{1}{25}$   $\frac{1}{10}$   $\frac{1}{25}$



75.    





II.    I.   

$\frac{1}{2}$   $\frac{1}{4}$   $\frac{1}{2}$   $\frac{1}{4}$   $\frac{1}{2}$   $\frac{1}{4}$   $\frac{1}{2}$   $\frac{1}{4}$   $\frac{1}{2}$   $\frac{1}{4}$   $\frac{1}{2}$   $\frac{1}{4}$   $\frac{1}{2}$   $\frac{1}{4}$





39.  Pz. D.  

$\frac{1}{3}$   $\frac{1}{12}$   $\frac{1}{2}$

39.  





6./59    











12  $\frac{1}{12}$   $\frac{1}{6}$   $\frac{1}{12}$   $\frac{1}{6}$   $\frac{1}{12}$   $\frac{1}{6}$

39.    



$\frac{1}{9}$   $\frac{1}{9}$   $\frac{1}{9}$



le le le

83  83  83  83  83 

83.          

9 8 7 6 5 4 3 2 1

83  2./83  1./83 

$\frac{3}{83}$   $\frac{2}{83}$   $\frac{1}{83}$   2./82  1./83

## 4. Panzer-Division

Activated 10.11.1938  
 Mobilized 22.08.1939  
 Home Garrison XIII Wehrkreis  
 Status on 1.09.1939

Assigned to XIV. Armeekorps (mot), 10. Armee, Heeresgruppe Süd  
 Commanding General Generalmajor (US equivalent is Brigadier General □ )  
 Georg-Hans Reinhardt

## Authorized Strength in accordance with the Mobilization Plan 1939/1940

	Division Total	Division Headquarters <sup>4</sup>	Infantry Regiment	Panzer Brigade	Artillery Regiment	Recon Battalion	Anti-Tank Battalion	Engineers	Signal Battalion	Support Services
Officers	351	18	61	120	44	26	18	9	13	42
Government Service Officials	111	14	8	22	6	4	3	1	3	50
Non-Commissioned Officers	1,762	26	341	682	156	116	104	41	83	213
Enlisted Men	8,062	107	1,850	2,112	997	607	439	330	323	1,297
<b>Total</b>	<b>10,286</b>	<b>165</b>	<b>2,260</b>	<b>2,936</b>	<b>1,203</b>	<b>753</b>	<b>564</b>	<b>381</b>	<b>422</b>	<b>1,602</b>
Pistols	3,838	50	596	1,801	210	326	208	55	196	396
Rifles	6,161	111	1,664	1,111	993	427	356	326	326	847
Sub-Machine Guns	433	–	6	336	–	62	–	–	27	–
Light Machine Guns <sup>1</sup>	749	–	116	508	12	68	12	9	15	–
Heavy Machine Guns	28	2	24	–	–	2	–	–	–	–
20mm AA Guns	12	–	–	–	–	–	12	–	–	–
37mm AT Guns	33	–	6	–	–	3	24	–	–	–
light (50mm) Mortars	21	–	18	–	–	3	–	–	–	–
heavy (81mm) Mortars	12	–	12	–	–	–	–	–	–	–
light (75mm) Infantry Guns	10	–	8	–	–	2	–	–	–	–
heavy (150mm) Infantry Guns	–	–	–	–	–	–	–	–	–	–
light (105mm) Field Howitzers	24	–	–	–	24	–	–	–	–	–
heavy (105mm) Guns	–	–	–	–	–	–	–	–	–	–
heavy (150mm) Field Howitzers	–	–	–	–	–	–	–	–	–	–
20mm AFV Guns	158	–	–	138	–	20	–	–	–	–
37mm AFV Guns	20	–	–	20	–	–	–	–	–	–
75mm AFV Guns	24	–	–	24	–	–	–	–	–	–
Gun Tanks	182	–	–	182	–	–	–	–	–	–
Other Tanks <sup>2</sup>	133	–	–	126	–	–	–	–	7	–
Armored Cars <sup>3</sup>	88	–	6	–	–	60	2	–	20	–
<b>Total AFV</b>	<b>423</b>	<b>–</b>	<b>6</b>	<b>328</b>	<b>–</b>	<b>60</b>	<b>2</b>	<b>–</b>	<b>27</b>	<b>–</b>
Personnel Carriers	466	11	87	88	104	34	36	16	40	48
Load Carriers	1,321	13	281	326	143	68	71	72	35	312
Motorcycles	509	40	103	138	88	37	9	20	24	33
Motorcycles with sidecars	407	1	84	108	22	82	6	12	3	61
Trailers	87	–	4	26	24	1	12	3	3	14

1) LMG includes those mounted on AFV.

2) Other tanks are command tanks, signal tanks, and MG-equipped tanks.

3) Armored Cars include command armored cars, signal armored cars, MG-equipped armored cars, and gun-equipped armored cars.

4) Including the Headquarters, Panzer Division; the Motorcycle Messenger Platoon; and the Motorized Mapping Detachment.

## Tank Strength on 1.09.1939

Div.	Brig.	Rgt.	Bn.	Tank Companies		Tanks						Total	
				light	medium	Pz-I	Pz-II	Pz/35	Pz/38	Pz-III	Pz-IV		Pz-Bef
4. Pz	5.	35.	I & II	2	1	99	64	–	–	–	6	8	163
			36. I & II	2	1	84	66	–	–	–	6	8	150

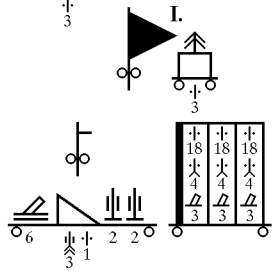
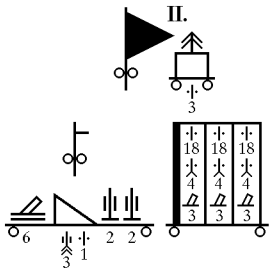
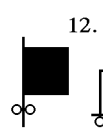
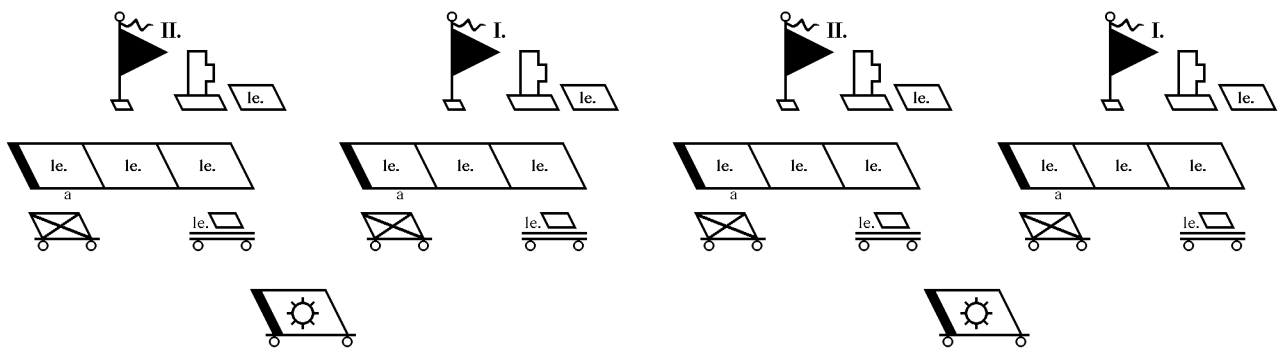
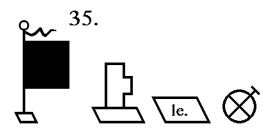
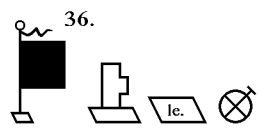
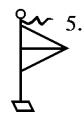
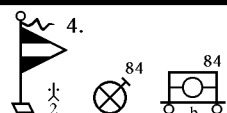

le. Inf.

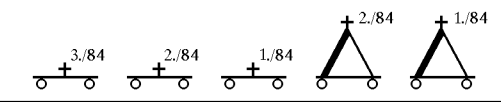
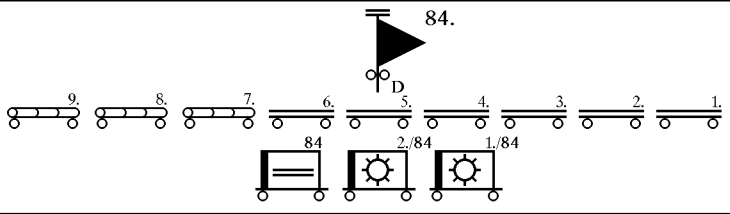
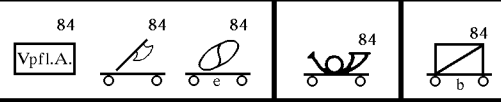
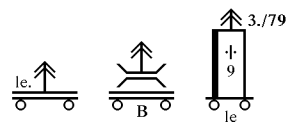
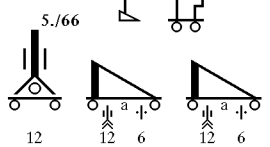
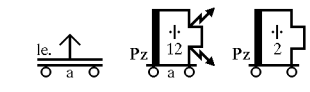
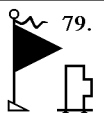
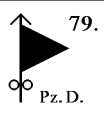
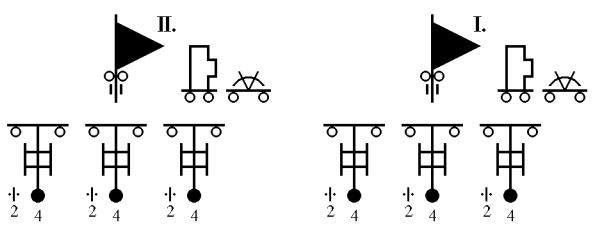
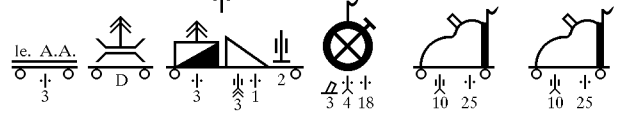
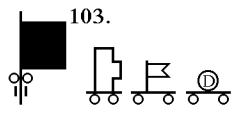
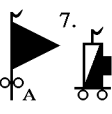

## 5. Panzer-Division

Activated 24.11.1938  
 Mobilized 18.08.1939  
 Home Garrison VIII Wehrkreis  
 Status on 1.09.1939

Assigned to VIII. Armeekorps, 14. Armee, Heeresgruppe Süd  
 Commanding General Generalleutnant (US equivalent is Major General □ □ )  
 Heinrich Freiherr von Vietinghoff, genannt Scheel

## Authorized Strength in accordance with the Mobilization Plan 1939/1940

	Division Total	Division Headquarters <sup>4</sup>	Infantry Regiments	Panzer Brigade	Artillery Regiment	Recon Battalion	Anti-Tank Battalion	Engineer Battalion	Signal Battalion	Support Services
Officers	421	18	122	120	44	26	22	18	13	42
Government Service Officials	120	14	16	22	6	4	3	2	3	50
Non-Commissioned Officers	2,108	26	664	682	156	116	132	65	83	213
Enlisted Men	10,130	107	3,752	2,112	997	607	551	525	323	1,297
<b>Total</b>	<b>12,779</b>	<b>165</b>	<b>4,554</b>	<b>2,936</b>	<b>1,203</b>	<b>753</b>	<b>708</b>	<b>610</b>	<b>422</b>	<b>1,602</b>
Pistols	4,516	50	1,236	1,801	210	320	204	103	196	396
Rifles	7,806	111	3,248	1,111	993	436	327	507	326	847
Sub-Machine Guns	439	–	12	336	–	62	2	–	27	–
Light Machine Guns <sup>1</sup>	870	–	232	508	12	67	18	18	15	–
Heavy Machine Guns	52	2	48	–	–	2	–	–	–	–
20mm AA Guns	–	–	–	–	–	–	–	–	–	–
37mm AT Guns	48	–	12	–	–	–	36	–	–	–
light (50mm) Mortars	39	–	36	–	–	3	–	–	–	–
heavy (81mm) Mortars	24	–	24	–	–	–	–	–	–	–
light (75mm) Infantry Guns	20	–	16	–	–	4	–	–	–	–
heavy (150mm) Infantry Guns	–	–	–	–	–	–	–	–	–	–
light (105mm) Field Howitzers	24	–	–	–	24	–	–	–	–	–
heavy (105mm) Guns	–	–	–	–	–	–	–	–	–	–
heavy (150mm) Field Howitzers	–	–	–	–	–	–	–	–	–	–
20mm AFV Guns	158	–	–	138	–	20	–	–	–	–
37mm AFV Guns	20	–	–	20	–	–	–	–	–	–
75mm AFV Guns	24	–	–	24	–	–	–	–	–	–
Gun Tanks	182	–	–	182	–	–	–	–	–	–
Other Tanks <sup>2</sup>	133	–	–	126	–	–	–	–	7	–
Armored Cars <sup>3</sup>	94	–	12	–	–	60	–	–	20	–
<b>Total AFV</b>	<b>429</b>	<b>–</b>	<b>12</b>	<b>328</b>	<b>–</b>	<b>60</b>	<b>–</b>	<b>–</b>	<b>27</b>	<b>–</b>
Personnel Carriers	612	11	198	88	104	36	56	31	40	48
Load Carriers	1,512	13	470	328	143	66	53	94	35	312
Motorcycles	653	40	234	138	88	37	23	32	24	33
Motorcycles with sidecars	727	1	384	108	22	84	40	24	3	61
Trailers	89	–	8	26	24	2	12	–	3	14

1) LMG includes those mounted on AFV.

2) Other tanks are command tanks, signal tanks, and MG-equipped tanks.

3) Armored Cars include command armored cars, signal armored cars, MG-equipped armored cars, and gun-equipped armored cars.

4) Including the Headquarters, Panzer Division; the Motorcycle Messenger Platoon; and the Motorized Mapping Detachment.

## Tank Strength on 1.09.1939

Div.	Brig.	Rgt.	Bn.	Tank Companies		Tanks						Total	
				light	medium	Pz-I	Pz-II	Pz/35	Pz/38	Pz-III	Pz-IV		Pz-Bef
5. Pz	8.	15.	I & II	2	1	72	81	–	–	3	8	11	156
		31.	I & II	2	1	80	63	–	–	–	6	11	143

1.09.1939

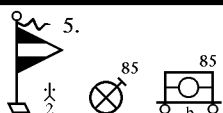
5. 

8. 

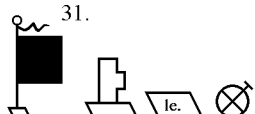
31. 

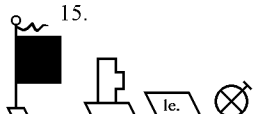
15. 

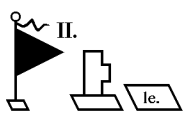
II. 

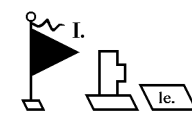
I. 

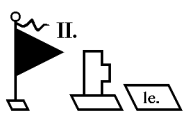
II. 

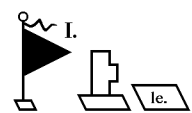
I. 

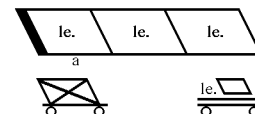
le. 

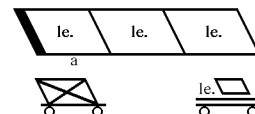
le. 

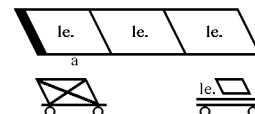
le. 

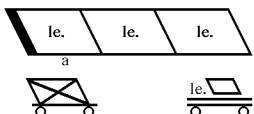
le. 

a 

a 

a 

a 



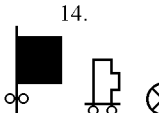

14. 

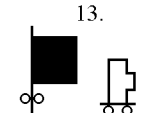
13. 

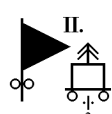
II. 

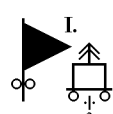
I. 

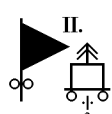
II. 

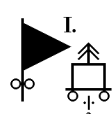
I. 

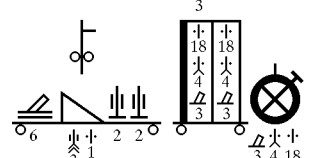

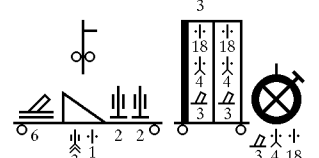

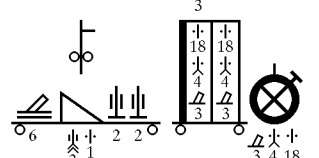

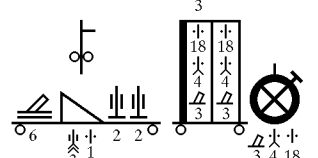



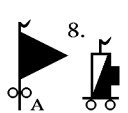

le. Inf. 

le. Inf. 

8. 

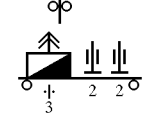
le. A.A. 





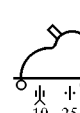

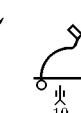

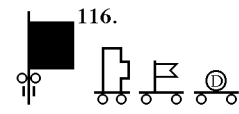
116. 

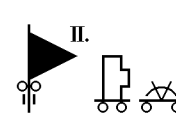
II. 

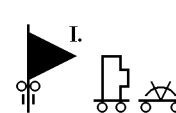
I. 

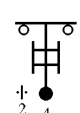

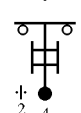

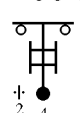

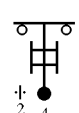

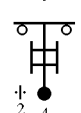

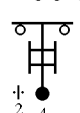

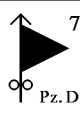
77. 

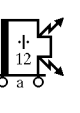
Pz. D. 

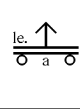
le. 

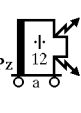
Pz. 

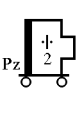
Pz. 

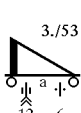
3./53 

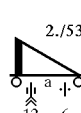
2./53 

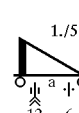
1./53 

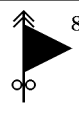
89. 

le. 

K 

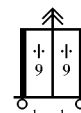
le le 

85 

Vpfl.A. 

85 

85 

85 

85 

85. 

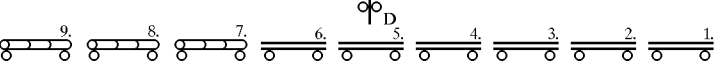



85 

2./85 

1./85 

3./85 

2./85 

1./85 

2./85 

1./85 

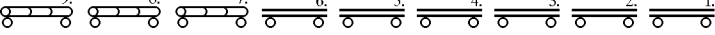

85 

2./85 

1./85 

## 1. leichte Division

Activated 20.11.1938  
 Mobilized 1.08.1939  
 Home Garrison VI Wehrkreis  
 Status on 1.09.1939

Assigned to 10. Armee Reserve, Heeresgruppe Süd  
 Commanding General Generalmajor (US equivalent is Brigadier General □ )  
 Wilhelm von Loeper

## Authorized Strength in accordance with the Mobilization Plan 1939/1940

	Division Total	Division Headquarters <sup>4</sup>	Infantry Units	Panzer Battalion	Artillery Regiment	Recon Battalion	Anti-Tank Battalion	Engineer Battalion	Signal Company	Support Services
Officers	302	16	103	27	44	26	22	18	4	42
Government Service Officials	101	11	14	4	6	4	3	2	–	57
Non-Commissioned Officers	1,485	25	607	128	156	116	132	65	44	212
Enlisted Men	8,047	100	3,328	479	997	607	551	525	131	1,329
<b>Total</b>	<b>9,935</b>	<b>152</b>	<b>4,052</b>	<b>638</b>	<b>1,203</b>	<b>753</b>	<b>708</b>	<b>610</b>	<b>179</b>	<b>1,640</b>
Pistols	2,773	42	1,093	318	210	326	259	103	8	414
Rifles	6,799	106	2,959	320	993	427	444	507	171	867
Sub-Machine Guns	160	–	10	88	–	62	–	–	–	–
Light Machine Guns <sup>1</sup>	465	–	220	129	12	68	18	18	–	–
Heavy Machine Guns	60	2	56	–	–	2	–	–	–	–
20mm AA Guns	12	–	–	–	–	–	12	–	–	–
37mm AT Guns	51	–	12	–	–	3	36	–	–	–
light (50mm) Mortars	39	–	36	–	–	3	–	–	–	–
heavy (81mm) Mortars	24	–	24	–	–	–	–	–	–	–
light (75mm) Infantry Guns	10	–	8	–	–	2	–	–	–	–
heavy (150mm) Infantry Guns	–	–	–	–	–	–	–	–	–	–
light (105mm) Field Howitzers	24	–	–	–	24	–	–	–	–	–
heavy (105mm) Guns	–	–	–	–	–	–	–	–	–	–
heavy (150mm) Field Howitzers	–	–	–	–	–	–	–	–	–	–
20mm AFV Guns	58	–	–	38	–	20	–	–	–	–
37mm AFV Guns	1	–	–	1	–	–	–	–	–	–
75mm AFV Guns	–	–	–	–	–	–	–	–	–	–
Gun Tanks	39	–	–	39	–	–	–	–	–	–
Other Tanks <sup>2</sup>	47	–	–	47	–	–	–	–	–	–
Armored Cars <sup>3</sup>	70	–	10	–	–	60	–	–	–	–
<b>Total AFV</b>	<b>156</b>	<b>–</b>	<b>10</b>	<b>86</b>	<b>–</b>	<b>60</b>	<b>–</b>	<b>–</b>	<b>–</b>	<b>–</b>
Personnel Carriers	523	11	188	18	104	34	45	31	41	51
Load Carriers	1,296	13	469	105	143	68	91	94	6	307
Motorcycles	453	40	145	32	88	37	32	32	10	33
Motorcycles with sidecars	521	1	258	23	22	82	46	24	1	64
Trailers	122	–	16	50	24	1	12	–	1	18

1) LMG includes those mounted on AFV.

2) Other tanks are command tanks, signal tanks, and MG-equipped tanks.

3) Armored Cars include command armored cars, signal armored cars, MG-equipped armored cars, and gun-equipped armored cars.

4) Including the Headquarters, Panzer Division; the Motorcycle Messenger Platoon; and the Motorized Mapping Detachment.

## Tank Strength on 1.09.1939

Div.	Brig.	Rgt.	Bn.	Tank Companies		Tanks							
				light	medium	Pz-I	Pz-II	Pz/35	Pz/38	Pz-III	Pz-IV	Pz-Bef	Total
1. lei	–	–	65.	2	1	–	20	37	–	–	14	2 <sup>1</sup>	57

1) 2 Pz LTM 35 as Panzerbefehlswagen.



1. lei. 1.09.1939

65.

m. le. le.

6. 4. III. II. I.

6. le. A.A.

76. II. I.

82. Pz. D.

41. 3./46

57.

57 Vpfl.A.

57. D.

## 2. leichte Division

Activated 10.11.1938  
 Mobilized 19.08.1939  
 Home Garrison IX Wehrkreis

Status on 1.09.1939

Assigned to XV. Armeekorps (mot), 10. Armee, Heeresgruppe Süd  
 Commanding General Generalleutnant (US equivalent is Major General □ □ )  
 Georg Stumme

## Authorized Strength in accordance with the Mobilization Plan 1939/1940

	Division Total	Division Headquarters <sup>4</sup>	Infantry Regiments	Panzer Battalion	Artillery Regiment	Recon Regiment	Anti-Tank Battalion	Engineer Battalion	Signal Company	Support Services
Officers	353	16	120	27	44	60	22	18	4	42
Government Service Officials	106	11	16	4	6	7	3	2	–	57
Non-Commissioned Officers	1,717	25	680	128	156	275	132	65	44	212
Enlisted Men	9,336	100	3,682	479	997	1,530	551	525	131	1,329
<b>Total</b>	<b>11,512</b>	<b>152</b>	<b>4,498</b>	<b>638</b>	<b>1,203</b>	<b>1,872</b>	<b>708</b>	<b>610</b>	<b>179</b>	<b>1,640</b>
Pistols	3,293	42	1,188	318	210	751	259	103	8	414
Rifles	7,856	106	3,310	320	993	1,121	461	507	171	867
Sub-Machine Guns	219	–	12	88	–	119	–	–	–	–
Light Machine Guns <sup>1</sup>	575	–	232	129	12	166	18	18	–	–
Heavy Machine Guns	62	2	48	–	–	12	–	–	–	–
20mm AA Guns	12	–	–	–	–	–	12	–	–	–
37mm AT Guns	51	–	12	–	–	3	36	–	–	–
light (50mm) Mortars	45	–	36	–	–	9	–	–	–	–
heavy (81mm) Mortars	30	–	24	–	–	6	–	–	–	–
light (75mm) Infantry Guns	20	–	16	–	–	4	–	–	–	–
heavy (150mm) Infantry Guns	–	–	–	–	–	–	–	–	–	–
light (105mm) Field Howitzers	24	–	–	–	24	–	–	–	–	–
heavy (105mm) Guns	–	–	–	–	–	–	–	–	–	–
heavy (150mm) Field Howitzers	–	–	–	–	–	–	–	–	–	–
20mm AFV Guns	78	–	–	38	–	40	–	–	–	–
37mm AFV Guns	1	–	–	1	–	–	–	–	–	–
75mm AFV Guns	–	–	–	–	–	–	–	–	–	–
Gun Tanks	39	–	–	39	–	–	–	–	–	–
Other Tanks <sup>2</sup>	47	–	–	47	–	–	–	–	–	–
Armored Cars <sup>3</sup>	127	–	12	–	–	115	–	–	–	–
<b>Total AFV</b>	<b>213</b>	<b>–</b>	<b>12</b>	<b>86</b>	<b>–</b>	<b>115</b>	<b>–</b>	<b>–</b>	<b>–</b>	<b>–</b>
Personnel Carriers	607	11	188	18	104	91	72	31	41	51
Load Carriers	1,442	13	560	105	143	138	76	94	6	307
Motorcycles	473	40	130	32	88	126	32	36	10	33
Motorcycles with sidecars	603	1	168	23	22	254	46	24	1	64
Trailers	127	–	8	50	24	2	12	–	1	18

1) LMG includes those mounted on AFV.

2) Other tanks are command tanks, signal tanks, and MG-equipped tanks.

3) Armored Cars include command armored cars, signal armored cars, MG-equipped armored cars, and gun-equipped armored cars.

4) Including the Headquarters, Panzer Division; the Motorcycle Messenger Platoon; and the Motorized Mapping Detachment.

## Tank Strength on 1.09.1939

Div.	Brig.	Rgt.	Bn.	Tank Companies		Tanks						Total	
				light	medium	Pz-I	Pz-II	Pz/35	Pz/38	Pz-III	Pz-IV		Pz-Bef
2. lei	–	–	66.	3	–	41	42	–	–	–	–	2	83

2. lei. 1.09.1939

66.

7. 6.

7.

78.

3./29

42. 3./59

58.

58 58 58

58.

3./58 2./58 1./58

58.

## 3. leichte Division

Activated 10.11.1938  
 Mobilized 28.08.1939  
 Home Garrison III Wehrkreis  
 Status on 1.09.1939

Assigned to 10. Armee Reserve, Heeresgruppe Süd  
 Commanding General Generalleutnant (US equivalent is Major General □ □ )  
 Adolf Kuntzen

## Authorized Strength in accordance with the Mobilization Plan 1939/1940

	Division Total	Division Headquarters <sup>4</sup>	Infantry Regiment	Panzer Battalion	Artillery Regiment	Recon Regiment	Anti-Tank Battalion	Engineer Battalion	Signal Company	Support Services
Officers	332	16	103	27	44	56	22	18	4	42
Government Service Officials	105	11	14	4	6	8	3	2	–	57
Non-Commissioned Officers	1,616	25	607	128	156	247	132	65	44	212
Enlisted Men	8,719	100	3,328	479	997	1,267	551	525	131	1,329
<b>Total</b>	<b>10,772</b>	<b>152</b>	<b>4,052</b>	<b>638</b>	<b>1,203</b>	<b>1,578</b>	<b>708</b>	<b>610</b>	<b>179</b>	<b>1,640</b>
Pistols	3,109	42	1,093	318	210	662	259	103	8	414
Rifles	7,300	106	2,959	320	993	916	461	507	171	867
Sub-Machine Guns	223	–	10	88	–	125	–	–	–	–
Light Machine Guns <sup>1</sup>	533	–	220	129	12	136	18	18	–	–
Heavy Machine Guns	62	2	56	–	–	4	–	–	–	–
20mm AA Guns	12	–	–	–	–	–	12	–	–	–
37mm AT Guns	54	–	12	–	–	6	36	–	–	–
light (50mm) Mortars	42	–	36	–	–	6	–	–	–	–
heavy (81mm) Mortars	24	–	24	–	–	–	–	–	–	–
light (75mm) Infantry Guns	12	–	8	–	–	4	–	–	–	–
heavy (150mm) Infantry Guns	–	–	–	–	–	–	–	–	–	–
light (105mm) Field Howitzers	24	–	–	–	24	–	–	–	–	–
heavy (105mm) Guns	–	–	–	–	–	–	–	–	–	–
heavy (150mm) Field Howitzers	–	–	–	–	–	–	–	–	–	–
20mm AFV Guns	78	–	–	38	–	40	–	–	–	–
37mm AFV Guns	1	–	–	1	–	–	–	–	–	–
75mm AFV Guns	–	–	–	–	–	–	–	–	–	–
Gun Tanks	39	–	–	39	–	–	–	–	–	–
Other Tanks <sup>2</sup>	47	–	–	47	–	–	–	–	–	–
Armored Cars <sup>3</sup>	131	–	10	–	–	121	–	–	–	–
<b>Total AFV</b>	<b>217</b>	<b>–</b>	<b>10</b>	<b>86</b>	<b>–</b>	<b>121</b>	<b>–</b>	<b>–</b>	<b>–</b>	<b>–</b>
Personnel Carriers	595	11	187	18	104	80	72	31	41	51
Load Carriers	1,368	13	484	105	143	140	76	94	6	307
Motorcycles	492	40	216	32	88	77	32	36	10	33
Motorcycles with sidecars	606	1	255	23	22	170	46	24	1	64
Trailers	135	–	16	50	24	2	12	–	1	18

1) LMG includes those mounted on AFV.

2) Other tanks are command tanks, signal tanks, and MG-equipped tanks.

3) Armored Cars include command armored cars, signal armored cars, MG-equipped armored cars, and gun-equipped armored cars.

4) Including the Headquarters, Panzer Division; the Motorcycle Messenger Platoon; and the Motorized Mapping Detachment.

## Tank Strength on 1.09.1939

Div.	Brig.	Rgt.	Bn.	Tank Companies		Tanks						Total	
				light	medium	Pz-I	Pz-II	Pz/35	Pz/38	Pz-III	Pz-IV		Pz-Bef
3. lei	–	–	67.	3	–	23	–	–	55	–	–	2 <sup>1</sup>	78

1) 2 Pz LTM 38 as Panzerbefehlswagen.

1.09.1939

3. lei.

67.

9.

II./9.      I./9.      II./8.      I./8.

le. Inf.      le. Inf.

8.

II.      I.

le. A.A.      le. A.A.

80.

II.      I.

4./3

43.

4./48

12      12 6      12 6      12 6

59.

le.      le.      le. le.

59      59      59

Vpfl.A.

59.

3./59      2./59      1./59      2./59      1./59

8      7      6      5      4      3      2      1

59      3./59      2./59      1./59

## 4. leichte Division

Activated 1.04.1938  
 Mobilized 19.08.1939  
 Home Garrison XVII Wehrkreis  
 Status on 1.09.1939

Assigned to XVIII. Armeekorps, 14. Armee, Heeresgruppe Süd  
 Commanding General Generalmajor (US equivalent is Major General □ □ )  
 Alfred Ritter von Hubicki

## Authorized Strength in accordance with the Mobilization Plan 1939/1940

	Division Total	Division Headquarters <sup>4</sup>	Infantry Regiments	Panzer Battalion	Artillery Regiment	Recon Regiment	Anti-Tank Battalion	Engineer Battalion	Signal Company	Support Services
Officers	346	16	122	27	44	55	18	18	4	42
Government Service Officials	106	11	16	4	6	7	3	2	–	57
Non-Commissioned Officers	1,685	25	696	128	156	254	103	67	44	212
Enlisted Men	9,170	100	3,756	479	997	1,428	407	543	131	1,329
<b>Total</b>	<b>11,307</b>	<b>152</b>	<b>4,590</b>	<b>638</b>	<b>1,203</b>	<b>1,744</b>	<b>531</b>	<b>630</b>	<b>179</b>	<b>1,640</b>
Pistols	3,211	42	1,190	318	210	667	196	103	8	414
Rifles	7,876	106	3,354	320	993	1,077	335	507	171	867
Sub-Machine Guns	192	–	12	88	–	92	–	–	–	–
Light Machine Guns <sup>1</sup>	550	–	232	129	12	141	18	18	–	–
Heavy Machine Guns	62	2	48	–	–	12	–	–	–	–
20mm AA Guns	–	–	–	–	–	–	–	–	–	–
37mm AT Guns	51	–	12	–	–	3	36	–	–	–
light (50mm) Mortars	45	–	36	–	–	9	–	–	–	–
heavy (81mm) Mortars	30	–	24	–	–	6	–	–	–	–
light (75mm) Infantry Guns	20	–	16	–	–	4	–	–	–	–
heavy (150mm) Infantry Guns	–	–	–	–	–	–	–	–	–	–
light (105mm) Field Howitzers	24	–	–	–	24	–	–	–	–	–
heavy (105mm) Guns	–	–	–	–	–	–	–	–	–	–
heavy (150mm) Field Howitzers	–	–	–	–	–	–	–	–	–	–
20mm AFV Guns	68	–	–	38	–	30	–	–	–	–
37mm AFV Guns	1	–	–	1	–	–	–	–	–	–
75mm AFV Guns	–	–	–	–	–	–	–	–	–	–
Gun Tanks	39	–	–	39	–	–	–	–	–	–
Other Tanks <sup>2</sup>	47	–	–	47	–	–	–	–	–	–
Armored Cars <sup>3</sup>	101	–	12	–	–	89	–	–	–	–
<b>Total AFV</b>	<b>187</b>	<b>–</b>	<b>12</b>	<b>86</b>	<b>–</b>	<b>89</b>	<b>–</b>	<b>–</b>	<b>–</b>	<b>–</b>
Personnel Carriers	594	11	190	18	104	88	58	33	41	51
Load Carriers	1,419	13	564	105	143	130	53	98	6	307
Motorcycles	473	40	206	32	88	120	23	36	10	33
Motorcycles with sidecars	603	1	168	23	22	246	40	24	1	64
Trailers	127	–	8	50	24	2	12	3	1	18

1) LMG includes those mounted on AFV.

2) Other tanks are command tanks, signal tanks, and MG-equipped tanks.

3) Armored Cars include command armored cars, signal armored cars, MG-equipped armored cars, and gun-equipped armored cars.

4) Including the Headquarters, Panzer Division; the Motorcycle Messenger Platoon; and the Motorized Mapping Detachment.

## Tank Strength on 1.09.1939

Div.	Brig.	Rgt.	Bn.	Tank Companies		Tanks						Total	
				light	medium	Pz-I	Pz-II	Pz/35	Pz/38	Pz-III	Pz-IV		Pz-Bef
4. lei	–	–	33.	3	–	34	23	–	–	–	–	5	57

1.09.1939

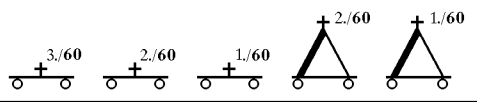
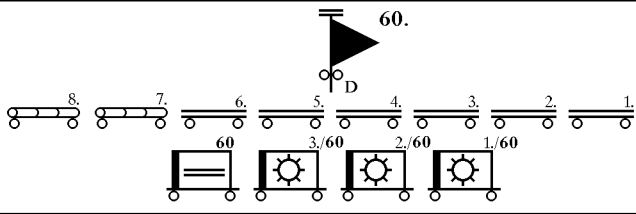
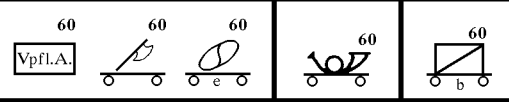
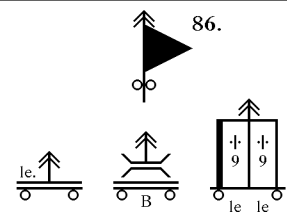
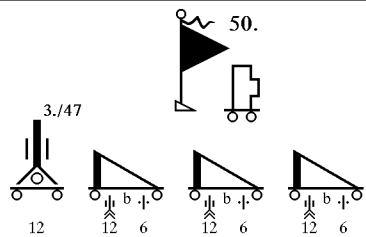
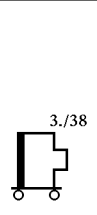
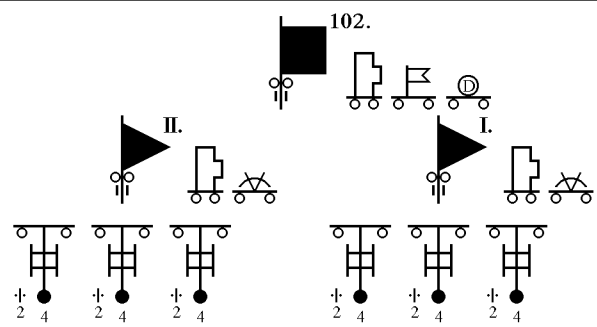
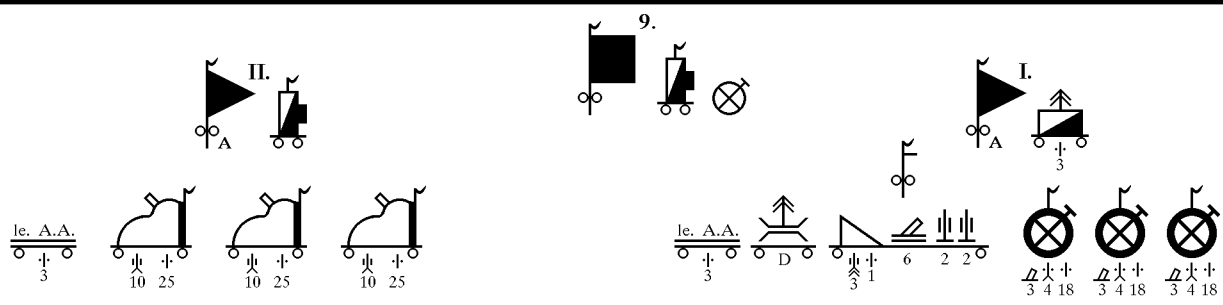
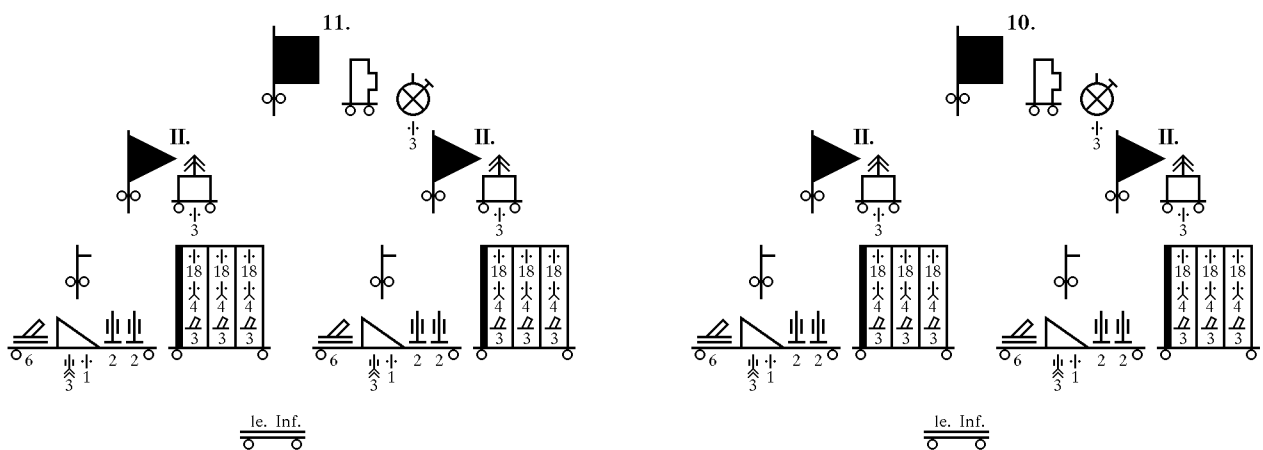
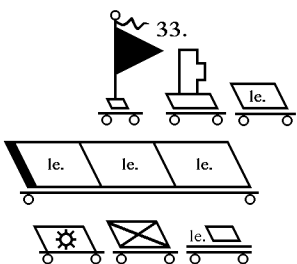
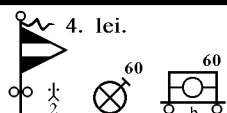

**Stab, 10. PANZER-DIVISION**  
**Headquarters, 10. Panzer Division**

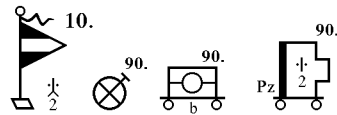

- KStN 51 Headquarters, Panzer Division**  
1.10.1937 Div Hqs: (16 Off; 14 GSO; 14 NCO; 53 EM).  
Div Gds: 1 truck (light); 1 Infantry Squad with 2 HMG.  
Motor Pool: 2 mcl; 2 cars (light); 3 cars (medium); 4 cars (11); 1 car (21);  
2 buses (light); 1 bus (medium – converted to office use);  
4 trucks (light); 1 truck (medium); 2 ambulances (medium van).
- KStN 1067 \*) Motorcycle Messenger Detachment**  
1.10.1938 Plt Hqs: 3 mcl; 1 mcl w/sc; 1 car (11).  
5 Sect: 7 mcl.
- KStN 2076 Motorized Mapping Detachment “b”**  
1.10.1938 Det: 1 car (light); 1 bus (light – converted to office use).
- KStN 981 Armored Signal Company**  
1.10.1937 Co Hqs: 2 mcl; 1 mcl w/sc; 2 cars (15); 1 truck (2-ton).  
1st Plt: Hqs Sect: 2 mcl; 1 car (15).  
1 Med Armd Radio Sect *b*: 1 car (15/6); 1 armored radio car (263).  
1 Tele Ops Sect *a*: 1 car (15/1); 1 van (17).  
2 Lt Tele Sect *b*: 1 car (15/1).  
1 Hvy Tele Sect *b*: 1 car /2/1; 1 van (77).  
2nd Plt: Hqs Sect: 2 mcl; 1 car (15).  
4 Hvy Tele Sect *b*: 1 car /2/1; 1 van (77).  
3rd Plt: Hqs Sect: 2 mcl; 1 car (15).  
1 Med Armd Radio Sect *b*: 1 car (15/6); 1 armored radio car (263).  
4 Lt Armd Radio Sect *d*: 1 radio armored car (261).  
1 Tele Ops Sect *a*: 1 car (15/1); 1 van (17).  
1 Hvy Tele Sect *b*: 1 car (2/1); 1 van (77).  
4 Lt Tele Sect *b*: 1 car (15/1).  
Personnel Reserve Det: 1 mcl; 1 car (2); 1 truck (2-ton).  
Co Trains: 2 mcl; 5 trucks (light); 1 van (42); 1 trailer (generator).

**NOTES:**

The 10. Panzer-Division was raised on 1.04.1939 and consisted only of a Headquarters, Panzer Division plus the 90. Nachrichten-Kompanie, raised especially for it. The unit was reorganized and expanded to full Panzer-Division size starting in October 1939.

On 1.09.1939, the 10. Panzer-Division had attached:

**From GHQ Troops:**

3./55. Flugabwehr-Kompanie (mot)  
49. Pionier-Bataillon (mot)  
8. Panzer-Regiment (4. Panzer-Brigade)  
misc. Supply and Support units

**From the 29. Infanterie-Division (mot):**

86. Infanterie-Regiment (mot)  
II./29. Artillerie-Abteilung (mot)  
3./29 Werkstatt-Kompanie (mot)

**From the 3. leichte Division (mot):**

I./8. Aufklärungs-Abteilung

**Stab, 10. Panzer-Division**

Activated 1.04.1939  
Mobilized 26.08.1939  
Home Garrison V Wehrkreis  
Status on 1.09.1939  
Assigned to OKH Reserves (for Heeresgruppe Nord)  
Commanding General Generalleutnant (US equivalent is Major General □ □ )  
Ferdinand Schaal



**STAB, PANZER-DIVISION**  
**Headquarters, Panzer Division**

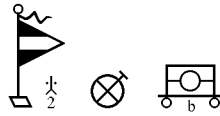

**KStN 51**  
1.10.1937

**Headquarters, Panzer Division**

Div Hqs: (16 Off; 14 GSO; 14 NCO; 53 EM).  
 Div Gds: 1 truck (light); 1 Infantry Squad with 2 HMG.  
 Motor Pool: 2 mcl; 2 cars (light); 3 cars (medium); 4 cars (11); 1 car (21);  
 2 buses (light); 1 bus (medium – converted to office use);  
 4 trucks (light); 1 truck (medium); 2 ambulances (medium van).

**KStN 1067 \*)**  
1.10.1938

**Motorcycle Messenger Detachment**

Plt Hqs: 3 mcl; 1 mcl w/sc; 1 car (11).  
 5 Sect: 7 mcl.

**KStN 2076**  
1.10.1938

**Motorized Mapping Detachment “b”**

Det: 1 car (light); 1 bus (light – converted to office use).

**STAB, LEICHTE-DIVISION (motorisiert)**  
**Headquarters, Light Mechanized Division**

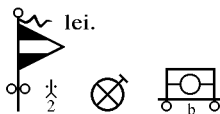

**KStN 41 \*)**  
1.10.1938

**Headquarters, Light Mechanized Division**

Div Hqs: (14 Off; 11 GSO; 11 NCO; 46 EM).  
 Div Gds: 1 truck (light); 1 Infantry Squad with 2 HMG.  
 Motor Pool: 2 mcl; 2 cars (light); 3 cars (medium); 4 cars (11); 1 car (21);  
 2 buses (light); 1 bus (medium – converted to office use);  
 3 trucks (light); 1 truck (medium); 2 ambulances (medium van).

**KStN 1067 \*)**  
1.10.1938

**Motorcycle Messenger Detachment**

Plt Hqs: 3 mcl; 1 mcl w/sc; 1 car (11).  
 5 Sect: 7 mcl.

**KStN 2076**  
1.10.1938

**Motorized Mapping Detachment “b”**

Det: 1 car (light); 1 bus (light – converted to office use).

**PANZER-BRIGADE**  
**Tank Brigade**

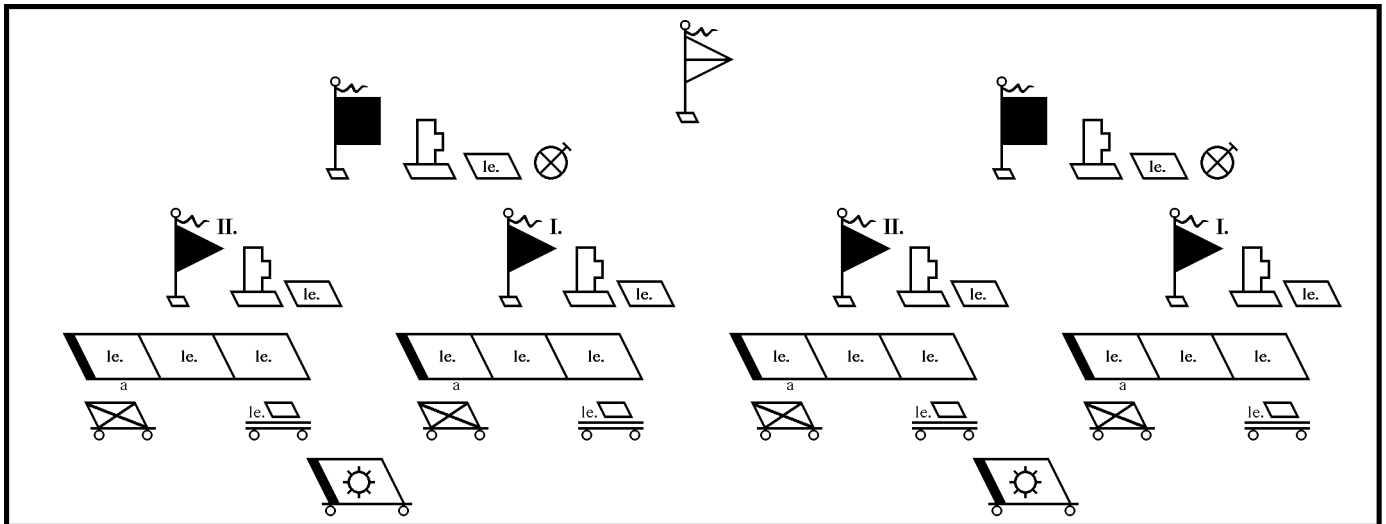

- KStN 53 Headquarters, Tank Brigade**  
1.10.1938  
Brig Hqs: 3 mcl; 4 mcl w/sc; 1 car (1); 1 car (11); 1 car (21).  
Brig Trains: 1 mcl; 1 car (15); 1 truck (light); 3 trucks (1.5-ton).
- KStN 1103 \*) Headquarters, Panzer Regiment**  
1.10.1937  
Rgt Hqs: 4 mcl; 2 mcl w/sc; 2 cars (15); 1 car (21).  
Maint Sect: 1 mcl w/sc; 1 car (2/40); 1 truck (3-ton).  
Rgt Hqs Trains: 1 mcl w/sc; 1 car (light); 1 car (15); 2 trucks (light); 2 trucks (1.5-ton); 2 trucks (3-ton); 1 bus (medium/32 seats).
- KStN 1194 Signal Platoon, Panzer Regiment**  
1.10.1937  
Plt: 2 Pz-Bef-III (267); 1 Pz-II (121).  
2 Lt Tele Sect c: 1 car (15/1).
- KStN 1168 \*) Light Tank Platoon:**  
1.10.1937  
Plt: 1 Pz-Bef-I (265); 2 Pz-II (121); 2 Pz-I (101);  
Trains: 1 mcl w/sc; 1 truck (1.5-ton).
- KStN 1067 \*) Motorcycle Messenger Detachment**  
1.10.1938  
Plt Hqs: 3 mcl; 1 mcl w/sc; 1 car (11).  
5 Sect: 7 mcl.
- KStN 1187 Motorized Tank Maintenance Company**  
1.10.1937  
Co Hqs: 1 mcl w/sc; 1 car (light).  
2 Maint Plt: 1 mcl w/sc; 1 car (light); 2 trucks (medium); 1 truck (1.5-ton); 1 truck (3-ton); 1 van (79); 4 halftracks (7); 1 halftrack (9);  
1 trailer (generator); 1 trailer (light tank); 4 trailers (heavy tank).  
Armorer Sect: 2 trucks (light).  
Signal Maint Sect: 2 trucks (1.5-ton); 1 van (42); 1 trailer (generator).  
Co Trains: 1 mcl w/sc; 1 car (light); 3 trucks (light).
- KStN 1107 \*) Headquarters, Panzer Battalion**  
1.10.1938  
Bn Hqs: 3 mcl; 3 cars (15).  
Mcl Plt: Hqs Sect: 1 mcl; 2 cars (15).  
3 Sect: 6 mcl; 1 mcl w/sc; 1 LMG.  
AA Plt: 4 AA cars (4 w/ dual MG).  
Engr Plt: Hqs Sect: 1 mcl; 1 mcl w/sc; 1 car (15).  
3 Sect: 1 car (15); 2 trucks (1.5-ton); 1 Engineer Section w/ 1 LMG.  
Maint Sect: 1 mcl w/sc; 1 car (2/40); 1 truck (3-ton).  
Bn Trains: 1 mcl w/sc; 1 car (light); 1 car (15); 6 trucks (1.5-ton); 4 trucks (3-ton).
- KStN 1195 Signal Platoon, Panzer Battalion**  
1.10.1938  
Plt: 1 Pz-III (141); 1 Pz-Bef-III (267); 1 Pz-Bef-I (265).  
2 Lt Tele Sect c: 1 car (15/1).
- KStN 1168 \*) Light Tank Platoon:**  
1.10.1937  
Plt: 1 Pz-Bef-I (265); 2 Pz-II (121); 2 Pz-I (101);  
Trains: 1 mcl w/sc; 1 truck (1.5-ton).
- KStN 1183 \*) Motorized Light Transport Column, Panzer Battalion**  
1.10.1938  
Col Hqs: 1 mcl; 1 mcl w/sc; 1 car (15).  
3 Sect: 8 trucks (3-ton).  
Maint Sect: 1 mcl w/sc; 1 car (2/40).  
Col Trains: 1 truck (light); 1 truck (2-ton).
- KStN 1178 \*) Reserve Tank Detachment**  
1.03.1939  
Det: 1 Pz-IV (161); 1 Pz-III (141); 2 Pz-II (121); 3 Pz-I (101).
- KStN 1171 \*) Light Tank Company**  
1.03.1939  
Co Hqs: 3 mcl; 1 car (15/2); 1 Pz-Bef-I (265); 2 Pz-II (121); 1 Pz-I (101).  
3 Tank Plt: 3 Pz-II (121); 2 Pz-I (101).  
1 Tank Plt: 5 Pz-II (121).  
Maint Sect: 1 mcl w/sc; 1 car (2/40); 1 truck (3-ton); 2 halftracks (10).  
Co Trains: 2 mcl w/sc; 1 car (15); 1 truck (light); 1 truck (medium); 7 trucks (3-ton).
- KStN 1175 \*) Light Tank Company "a"**  
1.03.1939  
Co Hqs: 3 mcl; 1 car (15/2); 1 Pz-Bef-I (265); 7 Pz-II (121).  
1 Tank Plt: 3 Pz-III (141).  
1 Tank Plt: 6 Pz-IV (161).  
Maint Sect: 1 mcl w/sc; 1 car (2/40); 1 truck (3-ton); 2 halftracks (10).  
Co Trains: 2 mcl w/sc; 1 car (15); 1 truck (light); 1 truck (medium); 7 trucks (3-ton).

**NOTES:**  
This organization applied to all Panzer Brigades except that of the 1. Panzer-Division.

**1939 PANZER-BRIGADE (Sonder Ausführung)  
1939 Tank Brigade (Special Organization)**

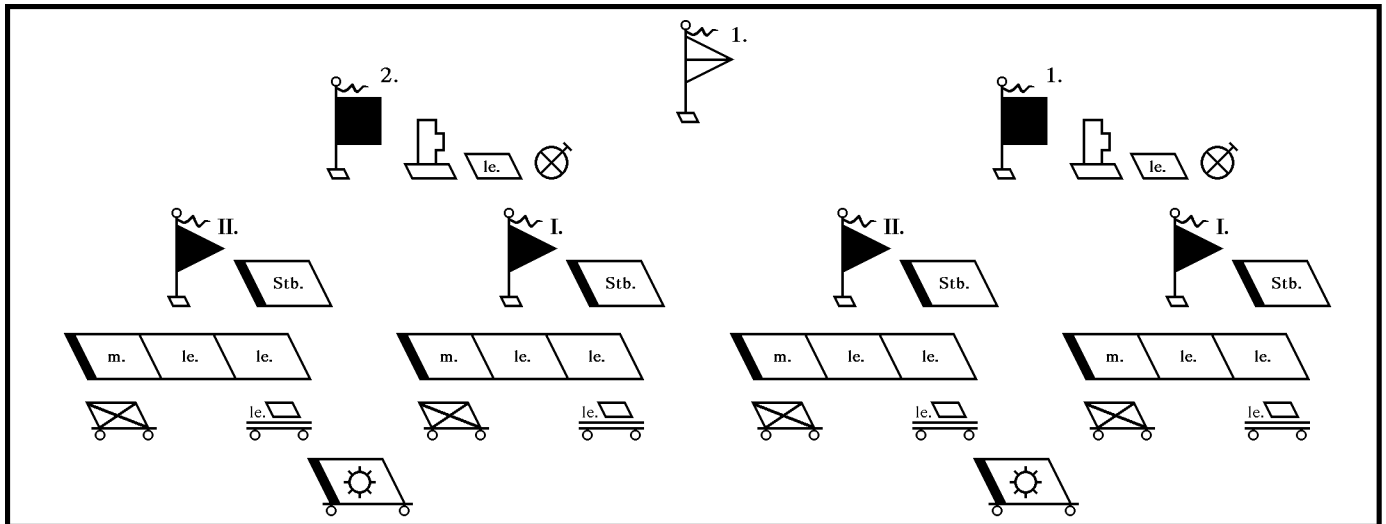
**KStN 53 Headquarters, Tank Brigade**

1.10.1937 Brig Hqs : 3 mcl; 4 mcl w/sc; 1 car (1); 1 car (11); 1 car (21).  
Brig Trains: 1 mcl; 1 car (15); 1 truck (light); 3 trucks (2-ton).

**KStN 1103(Sd) \*) Headquarters, Tank Regiment**

1.09.1939 Rgt Hqs: 4 mcl; 2 mcl w/sc; 2 cars (15); 1 car (21).  
Maint Sect: 1 mcl w/sc; 1 car (2/40); 1 truck (3-ton).  
Rgt Trains: 2 mcl; 1 car (1); 2 trucks (light); 2 trucks (2-ton); 5 trucks (3-ton); 1 bus (medium/30 seats).

**KStN 1194(Sd) \*) Signal Platoon, Tank Regiment**

1.09.1939 Hqs Sect: 1 mcl; 1 mcl w/sc; 1 car (15); 1 Pz-III (141).  
2 Lt Tele Sect c: 1 car (15).  
2 Armd Radio Sect: Bef-Pz-III (141).

**KStN 1168(Sd) \*) Light Tank Platoon, Tank Regiment**

1.09.1939 Plt: 1 mcl; 1 truck (light); 5 Pz-II (121).

**KStN 1187 Motorized Tank Maintenance Company, Tank Regiment**

1.10.1937 Co Hqs: 1 mcl; 1 mcl w/sc; 1 car (light).  
2 Workshop Plt: 1 car (light); 2 trucks (medium); 1 light truck (2-ton); 1 truck (3-ton); 2 van (79); 4 halftracks (7); 1 halftrack (9);  
1 trailer (generator); 1 trailer (10-ton/light tank); 4 trailers (22-ton/medium tank).  
Armorer Sect: 2 trucks (light).  
Signal Maint Sect: 2 trucks (2-ton); 1 van (42); 1 trailer (generator).  
Co Trains: 1 mcl w/sc; 1 car (light); 3 trucks (light).

**KStN 1107(Sd) \*) Headquarters, Tank Battalion**

1.09.1939 Bn Hqs: 2 mcl; 1 mcl w/sc; 1 car (light); 3 cars (15)

**KStN 1150(Sd) \*) Headquarters Company, Panzer Battalion**

1.09.1939 Co Hqs: 3 mcl; 1 car (15).  
Signal Plt: 1 Pz-III (141); 2 Pz-Bef-III (267).  
2 Lt Tele Sect c: 1 car (15/1).  
Lt Tank Plt: 1 mcl; 5 Pz-II (121).  
Scout Plt: Hqs Sect: 3 mcl; 1 car (1).  
4 Sect: 1 mcl; 2 mcl w/sc; 1 LMG.  
Engineer Plt: Hqs Sect: 1 mcl; 1 car (15).  
4 Engineer Sect: 1 truck (3-ton); 1 LMG.  
AA Plt: 4 cars (4 w/ dual MG).  
Maint Sect: 1 mcl w/sc; 1 car (2/40); 1 truck (3-ton).  
Co Trains: 1 mcl; 2 mcl w/sc; 1 car (light); 1 car (15); 7 trucks (2-ton); 2 trucks (medium); 6 trucks (3-ton); 1 ambulance (31).  
Bn Admin Det: 1 mcl; 1 car (light); 1 car (15); 1 truck (light).  
Bn Hqs Trains: 1 truck (light).

**KStN 1183(Sd) \*) Light Motorized Transport Column, Tank Battalion**

1.09.1939 Hqs Sect: 1 mcl; 1 mcl w/sc; 1 car (15).  
3 Transport Sect: 8 trucks (3-ton).  
Col Maint Sect: 1 mcl w/sc; 1 car (2/40).  
Col Trains: 1 truck (light); 1 truck (2-ton w/ field oven).

**KStN 1178(Sd) \*) Reserve Tank Detachment**

1.09.1939 Det: 1 Pz-IV (161); 3 Pz-III (141); 2 Pz-II (121).

**KStN 1171(Sd) \*) Light Tank Company**

1.09.1939 Co Hqs: 3 mcl; 1 car (15/2); 3 Pz-III (141).  
1 Tank Plt: 5 Pz-II (121).  
3 Tank Plt: 5 Pz-III (141).  
Maint Sect: 1 mcl w/sc; 1 car (2/40); 1 truck (3-ton); 2 halftracks (10).  
Co Trains: 2 mcl w/sc; 1 car (15); 1 truck (light); 1 truck (medium); 7 trucks (3-ton).

**KStN 1175(Sd) \*) Medium Tank Company**

1.09.1939 Co Hqs: 3 mcl; 1 car (15/2); 2 Pz-IV (141).  
1 Tank Plt: 5 Pz-II (121).  
3 Tank Plt: 4 Pz-IV (161).  
Maint Sect: 1 mcl w/sc; 1 car (2/40); 1 truck (3-ton); 2 halftracks (10).  
Co Trains: 2 mcl w/sc; 1 car (15); 1 truck (light); 1 truck (medium); 7 trucks (3-ton).

**NOTES:**

This organization applied only to the 1. and 2. Panzer-Regiments of the 1. Panzer-Division.

**PANZER-ABTEILUNG (LTM 35)**  
**Tank Battalion (Czechoslovakian LTM 35 Tanks)**

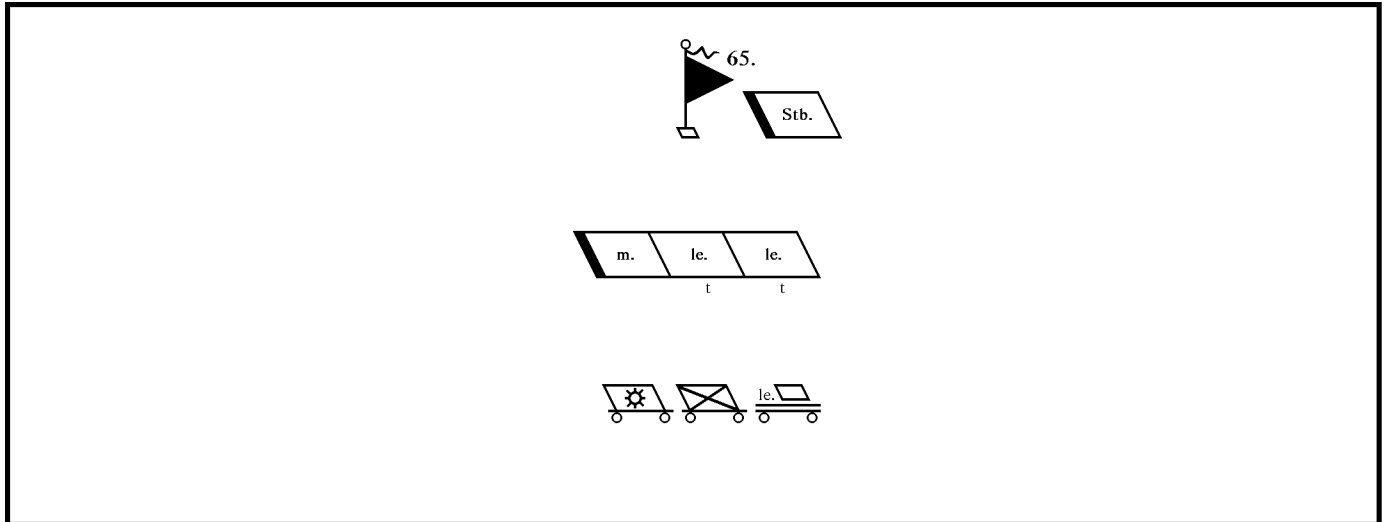

**KStN 1107(Sd) \*) Headquarters, Panzer Battalion**

1.09.1939 Bn Hqs: 3 mcl; 3 cars (15).

**KStN 1150(Sd) \*) Headquarters Company, Panzer Battalion**

1.09.1939

Hqs Sect:

Signal Plt: 1 Pz LTM 35; 2 Bef-Pz LTM 35.

2 Lt Tele Sect c: 1 car (15/1).

Lt Tank Plt: 5 Pz-II (121).

Mcl Plt: Hqs Sect: 1 mcl; 2 cars (15).

3 Sect: 6 mcl; 1 mcl w/sc; 1 LMG.

AA Plt: 4 AA cars (4 w/ dual MG).

Engr Plt: Hqs Sect: 1 mcl; 1 mcl w/sc; 1 car (15).

3 Sect: 1 car (15); 2 trucks (1.5-ton); 1 Engineer Section w/ 1 LMG.

Maint Sect: 1 mcl w/sc; 1 car (2/40); 1 truck (3-ton).

Bn Trains: 1 mcl w/sc; 1 car (light); 1 car (15); 6 trucks (1.5-ton); 4 trucks (3-ton).

**KStN 1183(Sd) \*) Motorized Light Transport Column, Panzer Battalion**

1.09.1939

Col Hqs: 1 mcl; 1 mcl w/sc; 1 car (15).

3 Sect: 8 trucks (3-ton).

Maint Sect: 1 mcl w/sc; 1 car (2/40).

Col Trains: 1 truck (light); 1 truck (2-ton).

**KStN 1178(Sd) \*) Reserve Tank Detachment**

1.09.1939

Det: 1 Pz-IV (161); 2 Pz LTM 35; 3 Pz-II (121).

**KStN 1185 \*) Motorized Tank Maintenance Platoon**

1.10.1937

Plt Hqs: 1 mcl w/sc; 1 car (light).

Maint Det: 1 mcl w/sc; 1 car (light); 2 trucks (medium); 1 truck (1.5-ton); 1 truck (3-ton); 1 van (79); 4 halftracks (7); 1 halftrack (9);

1 trailer (generator); 1 trailer (light tank); 4 trailers (heavy tank).

Armorer Sect: 1 truck (light).

Signal Maint Sect: 1 truck (1.5-ton); 1 van (42); 1 trailer (generator).

Plt Trains: 1 mcl w/sc; 1 car (light); 2 trucks (light).

**KStN 1171(Sd) \*) Light Tank Company**

1.09.1939

Co Hqs: 3 mcl; 1 car (15/2); 2 Pz LTM 35.

1 Tank Plt: 5 Pz-II (121).

3 Tank Plt: 5 Pz LTM 35.

Maint Sect: 1 mcl w/sc; 1 car (2/40); 1 truck (3-ton); 2 halftracks (10).

Co Trains: 2 mcl w/sc; 1 car (15); 1 truck (light); 1 truck (medium); 7 trucks (3-ton).

**KStN 1175(Sd) \*) Medium Tank Company "a"**

1.09.1939

Co Hqs: 3 mcl; 1 car (15/2); 2 Pz-IV (161).

1 Tank Plt: 5 Pz-II (121).

3 Tank Plt: 4 Pz-IV (161).

Maint Sect: 1 mcl w/sc; 1 car (2/40); 1 truck (3-ton); 2 halftracks (10).

Co Trains: 2 mcl w/sc; 1 car (15); 1 truck (light); 1 truck (medium); 7 trucks (3-ton).

**NOTES:**

This organization applied to:  
the 65. Panzer-Abteilung of the 1. leichte Division (motorisiert).

**PANZER-ABTEILUNG (Verlastet)**  
**Tank Battalion (truck-borne)**

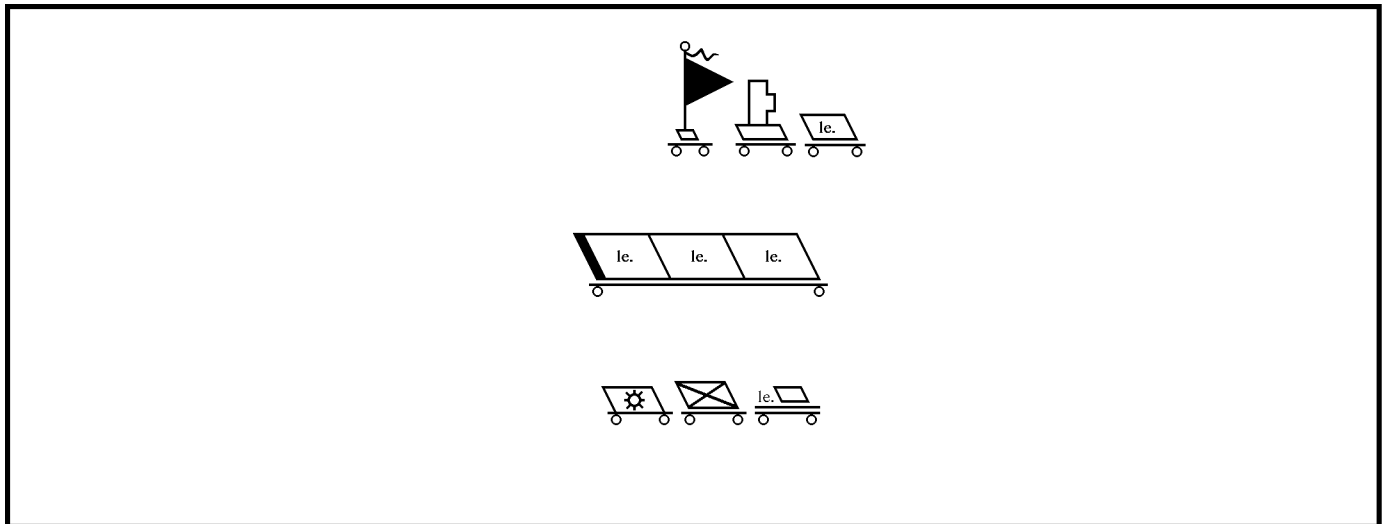

**KStN 1110 \*) Headquarters, Panzer Battalion (truck-borne)**

1.10.1938  
 Bn Hqs: 3 mcl; 3 cars (15).  
 Mcl Plt: Hqs Sect: 1 mcl; 2 cars (15).  
           3 Sect: 6 mcl; 1 mcl w/sc; 1 LMG.  
 AA Plt: 4 AA cars (4 w/ dual MG).  
 Engr Plt: Hqs Sect: 1 mcl; 1 mcl w/sc; 1 car (15).  
           3 Sect: 1 car (15); 2 trucks (1.5-ton); 1 Engineer Section w/ 1 LMG.  
 Maint Sect: 1 mcl w/sc; 1 car (2/40); 1 truck (3-ton).  
 Bn Trains: 1 mcl w/sc; 1 car (light); 1 car (15); 6 trucks (1.5-ton); 4 trucks (3-ton).

**KStN 1193 \*) Signal Platoon, Panzer Battalion (truck-borne)**

1.10.1938  
 Plt: 1 Pz-III (141); 1 Pz-Bef-III (267); 1 Pz-Bef-I (265).  
 2 Lt Tele Sect c: 1 car (15/1).  
 Transportation Sect: 2 trucks (9-ton); 2 trailers (tank).

**KStN 1169 \*) Light Tank Platoon (truck-borne)**

1.10.1937  
 Plt: 1 Pz-Bef-I (265); 2 Pz-II (121); 2 Pz-I (101).  
 Trains: 1 mcl w/sc; 1 truck (1.5-ton).  
 Transportation Sect: 3 trucks (9-ton); 2 trailers (tank).

**KStN 1183 \*) Motorized Light Transport Column, Panzer Battalion**

1.10.1938  
 Col Hqs: 1 mcl; 1 mcl w/sc; 1 car (15).  
 3 Sect: 8 trucks (3-ton).  
 Maint Sect: 1 mcl w/sc; 1 car (2/40).  
 Col Trains: 1 truck (light); 1 truck (2-ton).

**KStN 1180 \*) Reserve Tank Detachment (truck-borne)**

1.10.1938  
 Det: 3 Pz-II (121); 3 Pz-I (101).  
 Transportation Sect: 4 trucks (9-ton); 3 trailers (tank).

**KStN 1185 \*) Motorized Tank Maintenance Platoon**

1.10.1937  
 Plt Hqs: 1 mcl w/sc; 1 car (light).  
 Maint Det: 1 mcl w/sc; 1 car (light); 2 trucks (medium); 1 truck (1.5-ton); 1 truck (3-ton); 1 van (79); 4 halftracks (7); 1 halftrack (9);  
           1 trailer (generator); 1 trailer (light tank); 4 trailers (heavy tank).  
 Armorer Sect: 1 truck (light).  
 Signal Maint Sect: 1 truck (1.5-ton); 1 van (42); 1 trailer (generator).  
 Plt Trains: 1 mcl w/sc; 1 car (light); 2 trucks (light).

**KStN 1173 \*) Light Tank Company (truck-borne)**

1.10.1938  
 Co Hqs: 3 mcl; 1 car (15/2); 1 Pz-Bef-I (265); 3 Pz-II (121).  
 3 Tank Plt: 1 Pz-II (121); 4 Pz-I (101).  
 1 Tank Plt: 5 Pz-II (121).  
 Transportation Det: 12 trucks (9-ton); 12 trailers (tank).  
 Maint Sect: 1 mcl w/sc; 1 car (2/40); 1 truck (3-ton); 2 halftracks (10).  
 Co Trains: 2 mcl w/sc; 1 car (15); 1 truck (light); 1 truck (medium); 7 trucks (3-ton).

**NOTES:**

This organization applied to:  
 the 66. Panzer-Abteilung of the 2. leichte Division (motorisiert),  
 the 33. Panzer-Abteilung of the 4. leichte Division (motorisiert).

**PANZER-ABTEILUNG (Verlastet) (LTM 38)**  
**Tank Battalion (truck-borne) (Czechoslovakian LTM 38 Tanks)**

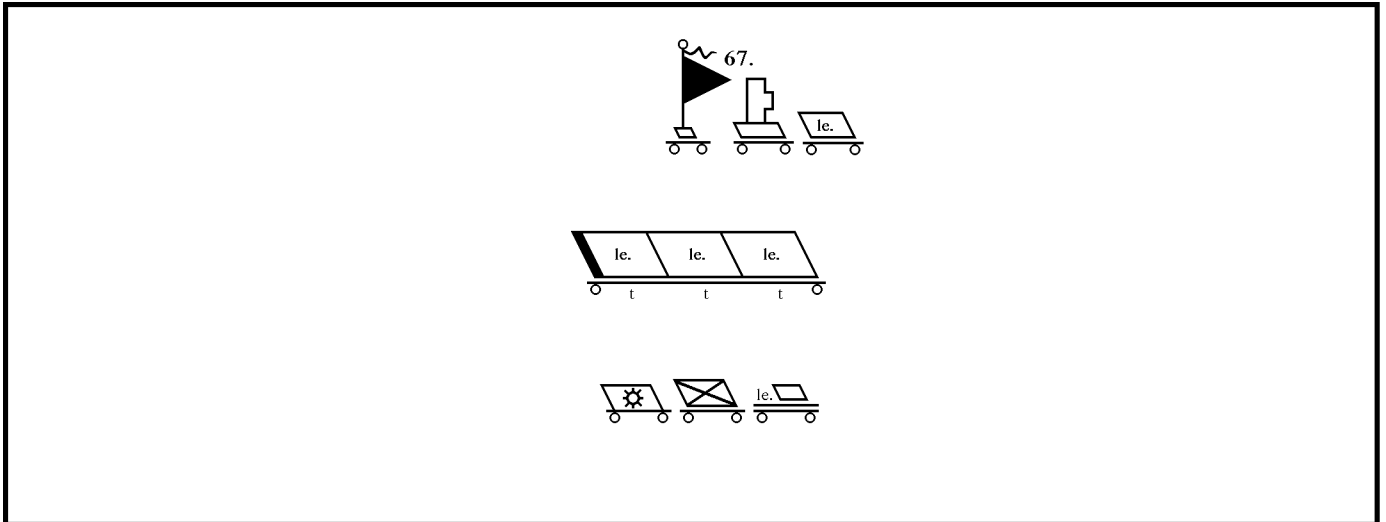

**KStN 1110 \*) Headquarters, Panzer Battalion (truck-borne)**

1.10.1938  
 Bn Hqs: 3 mcl; 3 cars (15).  
 Mcl Plt: Hqs Sect: 1 mcl; 2 cars (15).  
           3 Sect: 6 mcl; 1 mcl w/sc; 1 LMG.  
 AA Plt: 4 AA cars (4 w/ dual MG).  
 Engr Plt: Hqs Sect: 1 mcl; 1 mcl w/sc; 1 car (15).  
           3 Sect: 1 car (15); 2 trucks (1.5-ton); 1 Engineer Section w/ 1 LMG.  
 Maint Sect: 1 mcl w/sc; 1 car (2/40); 1 truck (3-ton).  
 Bn Trains: 1 mcl w/sc; 1 car (light); 1 car (15); 6 trucks (1.5-ton); 4 trucks (3-ton).

**KStN 1193 \*) Signal Platoon, Panzer Battalion (truck-borne)**

1.10.1938  
 Plt: 1 Pz LMT 38; 2 Pz-Bef LMT 38.  
 2 Lt Tele Sect c: 1 car (15/1).  
 Transportation Sect: 2 trucks (9-ton); 2 trailers (tank).

**KStN 1169 \*) Light Tank Platoon (truck-borne)**

1.10.1937  
 Plt: 5 Pz-II (121)  
 Trains: 1 mcl w/sc; 1 truck (1.5-ton).  
 Transportation Sect: 3 trucks (9-ton); 2 trailers (tank).

**KStN 1183 \*) Motorized Light Transport Column, Panzer Battalion**

1.10.1938  
 Col Hqs: 1 mcl; 1 mcl w/sc; 1 car (15).  
 3 Sect: 8 trucks (3-ton).  
 Maint Sect: 1 mcl w/sc; 1 car (2/40).  
 Col Trains: 1 truck (light); 1 truck (2-ton).

**KStN 1180 \*) Reserve Tank Detachment (truck-borne)**

1.10.1938  
 Det: 3 Pz-II (121); 3 Pz LMT 38.  
 Transportation Sect: 3 trucks (9-ton); 3 trailers (tank).

**KStN 1187 Motorized Tank Maintenance Company**

1.10.1937  
 Co Hqs: 1 mcl w/sc; 1 car (light).  
 2 Maint Plt: 1 mcl w/sc; 1 car (light); 2 trucks (medium); 1 truck (1.5-ton); 1 truck (3-ton); 1 van (79); 4 halftracks (7); 1 halftrack (9);  
           1 trailer (generator); 1 trailer (light tank); 4 trailers (heavy tank).  
 Armorer Sect: 2 trucks (light).  
 Signal Maint Sect: 2 trucks (1.5-ton); 1 van (42); 1 trailer (generator).  
 Co Trains: 1 mcl w/sc; 1 car (light); 3 trucks (light).

**KStN 1173 \*) Light Tank Company (truck-borne)**

1.10.1938  
 Co Hqs: 3 mcl; 1 car (15/2); 2 Pz LMT 38  
 3 Tank Plt: 5 Pz LMT 38  
 1 Tank Plt: 5 Pz-II (121).  
 Transportation Det: 11 trucks (9-ton); 11 trailers (tank).  
 Maint Sect: 1 mcl w/sc; 1 car (2/40); 1 truck (3-ton); 2 halftracks (10).  
 Co Trains: 2 mcl w/sc; 1 car (15); 1 truck (light); 1 truck (medium); 7 trucks (3-ton).

**NOTES:**

This organization applied to:  
 the 67. Panzer-Abteilung of the 3. leichte Division (motorisiert).

## SCHÜTZEN-BRIGADE Motorized Infantry Brigade



**KStN 54 \*)**  
1.10.1937

### Headquarters, Motorized Infantry Brigade

Brig Hqs: 6 mcl; 4 mcl w/sc; 2 cars (15); 1 car (21); 1 armored car (247).  
Brig Trains: 1 mcl; 1 car (15); 1 truck (light); 3 trucks (1.5-ton).

### Order of Battle – Motorized and Motorcycle Infantry of the Mechanized Divisions

Div.	Headquarters	Regimental Units	Battalion	Companies (indicating which KStN)	Heavy Company Platoons	
1. Pz	<b>1. Schützen-Brig</b> 1. Schützen-Rgt	Signal Plt	I. Schützen-Btl.	2 mot (1114) + 1 mcl (1111) + 1 mot MG (1116)	1 ATG 1 lt IG 1 Engr	
			II. Schützen-Btl.	2 mot (1114) + 1 mcl (1111) + 1 mot MG (1116)	1 ATG 1 lt IG 1 Engr	
			1. Krad-Schützen-Btl.	3 mcl (1111) + 1 mcl MG (1118)	1 ATG 1 lt IG 1 Engr	
2. Pz	<b>2. Schützen-Brig</b> 2. Schützen-Rgt	Signal Plt	I. Schützen-Btl.	2 mot (1114) + 1 mcl (1111) + 1 mot MG (1116)	1 ATG 1 lt IG 1 Engr	
			II. Schützen-Btl.	2 mot (1114) + 1 mcl (1111) + 1 mot MG (1116)	1 ATG 1 lt IG 1 Engr	
			2. Krad-Schützen-Btl.	3 mcl (1111) + 1 mcl MG (1118)	1 ATG 1 lt IG 1 Engr	
3. Pz	<b>3. Schützen-Brig</b> 3. Schützen-Rgt	Signal Plt	I. Schützen-Btl.	2 mot (1114) + 1 mcl (1111) + 1 mot MG (1116)	1 ATG 1 lt IG 1 Engr	
			II. Schützen-Btl.	2 mot (1114) + 1 mcl (1111) + 1 mot MG (1116)	1 ATG 1 lt IG 1 Engr	
			3. Krad-Schützen-Btl.	3 mcl (1111) + 1 mcl MG (1118)	1 ATG 1 lt IG 1 Engr	
4. Pz	12. Schützen-Rgt	Signal Plt	I. Schützen-Btl.	3 mot (1115)	1 ATG 1 lt IG 1 Engr <sup>1</sup> 1 Mort	
		Mcl Infantry Plt	II. Schützen-Btl.	3 mot (1115)	1 ATG 1 lt IG 1 Engr <sup>1</sup> 1 Mort	
5. Pz	13. Schützen-Rgt	Signal Plt	I. Schützen-Btl.	2 mot (1115) + 1 mcl (1111a)	1 ATG 2 lt IG 1 Engr <sup>1</sup> 1 Mort	
		Mcl Messenger Plt	II. Schützen-Btl.	2 mot (1115) + 1 mcl (1111a)	1 ATG 2 lt IG 1 Engr <sup>1</sup> 1 Mort	
	14. Schützen-Rgt	Signal Plt	I. Schützen-Btl.	2 mot (1115) + 1 mcl (1111a)	1 ATG 2 lt IG 1 Engr <sup>1</sup> 1 Mort	
		Mcl Messenger Plt	II. Schützen-Btl.	2 mot (1115) + 1 mcl (1111a)	1 ATG 2 lt IG 1 Engr <sup>1</sup> 1 Mort	
1. lei	<b>6. Schützen-Brig</b> 4. Kavallerie-Schützen-Rgt	Signal Plt 12./4 IG Company	I. Kav.-Schützen-Abt.	3 mot (1112) + 1 mot MG (1116)	1 ATG <sup>2</sup>	
			II. Kav.-Schützen-Abt.	3 mot (1112) + 1 mot MG (1116)	1 ATG <sup>2</sup>	
			III. Kav.-Schützen-Abt.	3 mot (1112) + 1 mot MG (1116)	1 ATG <sup>2</sup>	
			6. Krad-Schützen-Abt.	3 mcl (1113) + 1 mot MG (1116)	1 ATG <sup>2</sup>	
2. lei	6. Kavallerie-Schützen-Rgt	Signal Plt	I. Kav.-Schützen-Abt.	3 mot (1115)	1 ATG 2 lt IG 1 Engr <sup>1</sup> 1 Mort	
		Signal Plt	II. Kav.-Schützen-Abt.	3 mot (1115)	1 ATG 2 lt IG 1 Engr <sup>1</sup> 1 Mort	
7. Kavallerie-Schützen-Rgt	Signal Plt		I. Kav.-Schützen-Abt.	3 mot (1115)	1 ATG 2 lt IG 1 Engr <sup>1</sup> 1 Mort	
		II. Kav.-Schützen-Abt.	3 mot (1115)	1 ATG 2 lt IG 1 Engr <sup>1</sup> 1 Mort		
3. lei	9. Kavallerie-Schützen-Rgt	Signal Plt 9./8 IG Company 9./9 IG Company	I./8 Kav.-Schützen-Abt.	3 mot (1112) + 1 mot MG (1116)	1 ATG <sup>2</sup>	
			II./8 Kav.-Schützen-Abt.	3 mot (1112) + 1 mot MG (1116)	1 ATG <sup>2</sup>	
			I./9 Kav.-Schützen-Abt.	3 mot (1112) + 1 mot MG (1116)	1 ATG <sup>2</sup>	
			II./9 Krad-Schützen-Abt.	3 mcl (1113) + 1 mot MG (1116)	1 ATG <sup>2</sup>	
4. lei	10. Kavallerie-Schützen-Rgt	Signal Plt Mcl Messenger Plt	I. Kav.-Schützen-Abt.	3 mot (1115)	1 ATG 2 lt IG 1 Engr <sup>1</sup> 1 Mort	
			II. Kav.-Schützen-Abt.	3 mot (1115)	1 ATG 2 lt IG 1 Engr <sup>1</sup> 1 Mort	
			Signal Plt	I. Kav.-Schützen-Abt.	3 mot (1115)	1 ATG 2 lt IG 1 Engr <sup>1</sup> 1 Mort
				II. Kav.-Schützen-Abt.	3 mot (1115)	1 ATG 2 lt IG 1 Engr <sup>1</sup> 1 Mort

#### NOTES:

- The Engineer Platoons were attached directly to the Battalion Headquarters.
- No Heavy Company Headquarters.

The 1. Schützen-Regiment was the only unit equipped with armored personnel carriers (MTW) in 1939. Although no KStN had been published to include these new vehicles, KStN 1114 (for the motorized infantry company) had been modified by a General Army Order (AHM). This order specified for those infantry companies which were issued the MTW, a substitution on a one-for-two basis for the squad personnel carriers (Kfz. 70). However, as only 68 MTW were available on 1.09.1939, not all of the infantry companies were so equipped. It has not been possible to establish which companies were armored, or how the units were exactly organized and equipped. (The first official KStN for armored infantry would be issued on 1.12.1939).

There was no Headquarters, 8. Kavallerie-Schützen-Regiment.

#### Note on German Motorized Infantry Designations in 1939:

The motorized infantry of the Panzer-Division were designated as "Schützen", (lit.: Riflemen).

The motorized infantry of the leichte Division (motorisiert) were designated as "Kavallerie-Schützen", (lit.: Cavalry Riflemen).

The motorcycle and reconnaissance infantry of both types of division were designated as "Krad-Schützen", (lit.: Motorcycle Riflemen).

In keeping with the Cavalry tradition, all battalion echelon units of the regiments of the light mechanized divisions were designated as "Abteilung", (British Army designation would be Regiment; US Army designation would be Squadron).

All company echelon units of the battalions and regiments of the light mechanized divisions were designated as "Schwadron", (British Army designation would be Squadron; US Army designation would be Troop).

Hence, a motorized infantry company of a leichte Division (mot) was designated as "Kavallerie-Schützen-Schwadron".

**SCHÜTZEN-REGIMENT**  
**Motorized Infantry Regiment**

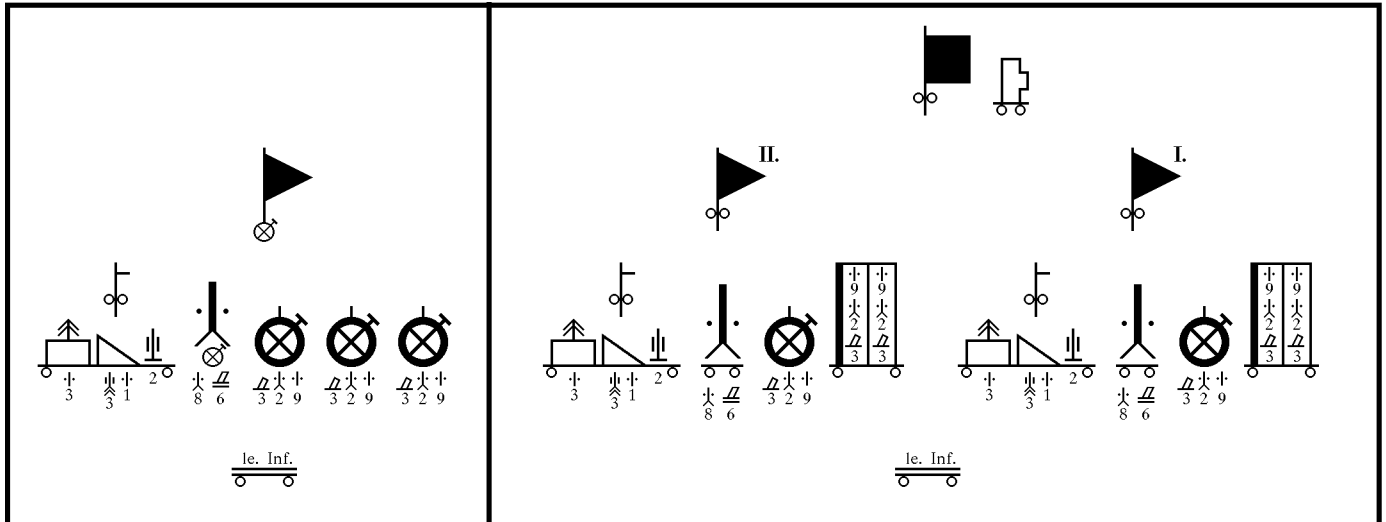

- KStN 1104 \*) Headquarters, Motorized Infantry Regiment**  
1.10.1937 Rgt Hqs: 5 mcl; 2 mcl w/sc; 2 cars (12).
- KStN 1197 \*) Signal Platoon, Motorized Infantry Regiment**  
1.03.1939 Plt Hqs: 1 mcl; 1 mcl w/sc; 1 cars (15/1); 2 cars (15/2).  
2 Lt Tele Sect c: 1 car (15/1).  
4 Pack Radio Sect d: ride in Platoon Headquarters vehicles.  
2 Lt Armored Radio Sect d: 1 radio armored car (261).
- KStN 202 Motorized Light Infantry Column**  
1.10.1937 Co Hqs: 2 mcl; 1 car (medium).  
Ammo Plt: 1 mcl w/sc; 13 trucks (light).  
Col Trains: 1 car (light); 3 trucks (light).
- KStN 1108 Headquarters, Motorized Infantry Battalion**  
1.10.1937 Bn Hqs: 5 mcl; 3 mcl w/sc; 1 car (11); 1 car (15).  
Signal Det: Hqs Sect: 1 car (15/2).  
2 Lt Tele Sect c: 1 car (15/2).  
2 Pack Radio Sect d: 1 car (2/2).  
2 Lt Armd Radio Sect d: 1 armored radio car (261).  
Maint Det: 1 mcl w/sc; 1 car (light); 2 trucks (light); 2 trucks (1.5-ton).  
Bn Trains: 3 mcl; 4 trucks (light); 1 truck (1.5-ton); 1 ambulance (31).
- KStN 1109 Headquarters, Independent Motorcycle Infantry Battalion**  
1.10.1937 Bn Hqs: 5 mcl; 3 mcl w/sc; 1 car (11); 1 car (15).  
Signal Det: Hqs Sect: 1 car (15/2).  
2 Lt Tele Sect c: 1 car (15/1).  
2 Pack Radio Sect b: 1 car (2/2).  
2 Lt Armd Radio Sect d: 1 armored radio car (261).  
Maint Det: 1 mcl w/sc; 1 car (light); 2 trucks (light); 2 trucks (1.5-ton).  
Bn Trains: 3 mcl; 2 cars (light); 3 trucks (light); 1 truck (1.5-ton); 1 ambulance (31).
- KStN 1114 \*) Motorized Infantry Company**  
1.10.1937 Co Hqs: 3 mcl; 2 mcl w/sc; 1 car (18).  
3 Inf Plt: Hqs Sect: 21 mcl; 1 car (18).  
3 Inf Sqd: 2 trucks (70); 1 Infantry Squad with 1 LMG.  
1 Mortar Sect: 1 truck (70); 1 mortar (50mm).  
MG Det: 2 trucks (70); 2 HMG.  
Co Trains: 2 mcl w/sc; 1 car (15); 1 truck (light); 5 trucks (1.5-ton).
- KStN 1111 Motorcycle Infantry Company**  
1.10.1937 Co Hqs: 3 mcl; 1 mcl w/sc; 1 car (11); 1 car (15).  
3 Mcl Plt: Hqs Sect: 2 mcl; 1 car (11); 1 car (18).  
3 Mcl Sqd: 3 mcl w/sc; 1 Infantry Squad with 1 LMG.  
1 Mortar Sect: 2 mcl w/sc; 1 mortar (50mm).  
MG Det: 10 mcl w/sc; 2 HMG.  
Co Trains: 2 mcl w/sc; 1 car (15); 1 truck (light); 5 trucks (1.5-ton).
- KStN 1116 \*) Motorized Machine Gun Company**  
1.10.1937 Co Hqs: 3 mcl; 1 mcl w/sc; 1 car (18); 1 truck (70).  
2 MG Plt: Hqs Sect: 2 mcl; 1 car (11); 1 car (18).  
1 Lt Tele Sect c: 1 car (15/2).  
2 MG Det: 2 trucks (70); 2 HMG..  
1 Mortar Plt: Hqs Sect: 1 mcl w/sc; 1 car (11); 1 truck (70).  
3 Mortar Sect: 1 car (11); 2 trucks (70); 2 mortars (81mm).  
Co Trains: 2 mcl w/sc; 1 car (15); 1 truck (light); 5 trucks (1.5-ton).
- KStN 1118 \*) Motorcycle Machine Gun Company**  
1.10.1938 Co Hqs: 3 mcl; 1 mcl w/sc; 1 car (18); 1 truck (70).  
2 MG Plt: Hqs Sect: 2 mcl; 1 car (11); 1 car (18).  
1 Lt Tele Sect c: 1 car (15/2).  
2 MG Det: 6 mcl w/sc; 2 HMG..  
1 Mortar Plt: Hqs Sect: 1 mcl w/sc; 1 car (11); 1 truck (70).  
3 Mortar Sect: 1 car (11); 2 trucks (70); 2 mortars (81mm).  
Co Trains: 2 mcl w/sc; 1 car (15); 1 truck (light); 5 trucks (1.5-ton).
- Motorized Heavy Company**  
Co Hqs: 2 mcl; 2 mcl w/sc; 1 car (11).  
Co Trains: 1 mcl; 2 mcl w/sc; 1 car (15); 5 trucks (1.5-ton); 1 truck (medium).  
ATG Plt: Hqs Sect: 1 mcl; 1 mcl w/sc; 1 truck (69).  
Gun Det: 4 trucks (69); 3 ATG (37mm – towed); 1 LMG.  
Lt IG Plt: Hqs Sect: 1 mcl; 2 mcl w/sc; 1 car (12).  
1 Lt Tele Sect c: 1 car (15/2).  
Gun Det: 3 trucks (69); 2 IG (75mm – towed); 1 trailer (ammo).  
Hqs Sect: 2 mcl; 1 mcl w/sc; 1 car (15).  
Engr Det: 1 mcl w/sc; 2 cars (15); 6 trucks (2-ton); 3 LMG.
- KStN 1121**  
1.10.1937
- KStN 1122**  
1.10.1937
- KStN 1123**  
1.10.1937
- KStN 1124**  
1.10.1937

**NOTES:**  
These KStN applied to the 1. Panzer-Division, the 2. Panzer-Division, the 3. Panzer-Division.

See Order of Battle on page 35 for details regarding units.



**SCHÜTZEN-REGIMENT**  
**Motorized Infantry Regiment**

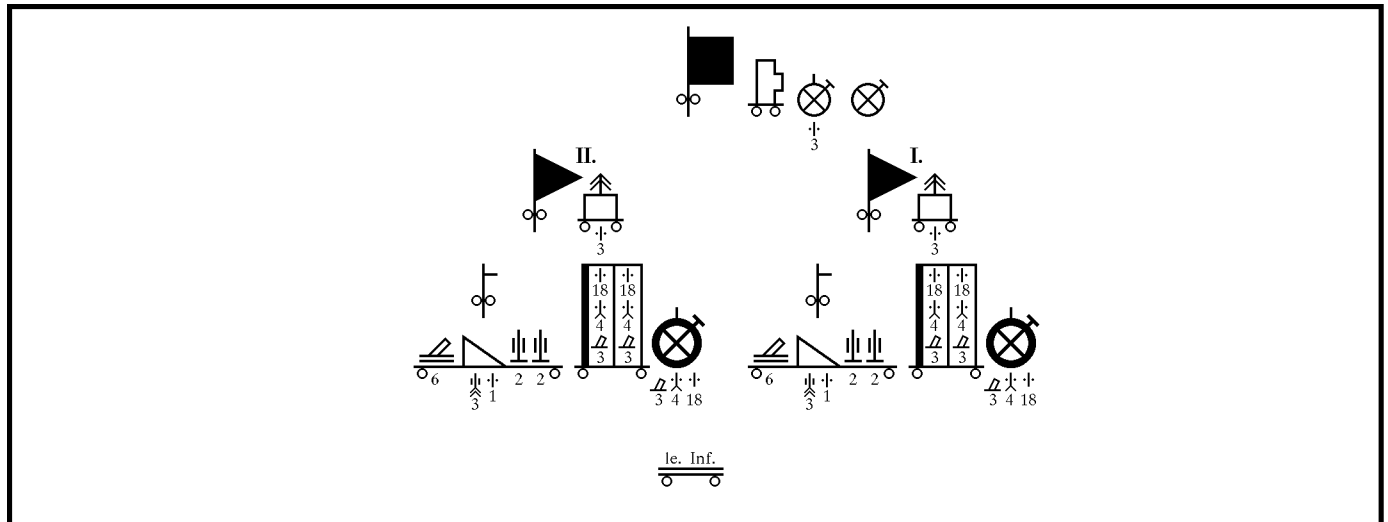

- KStN 1104 \*) Headquarters, Motorized Infantry Regiment**  
1.10.1937 Rgt Hqs: 5 mcl; 2 mcl w/sc; 2 cars (12).
- KStN 1197 \*) Signal Platoon, Motorized Infantry Regiment**  
1.03.1939 Plt Hqs: 1 mcl; 1 mcl w/sc; 1 cars (15/1); 2 cars (15/2).  
2 Lt Tele Sect c: 1 car (15/1).  
4 Pack Radio Sect d: ride in Platoon Headquarters vehicles.  
2 Lt Armored Radio Sect d: 1 radio armored car (261).
- KStN 1067 \*) Motorcycle Messenger Detachment**  
1.10.1938 Plt Hqs: 3 mcl; 1 mcl w/sc; 1 car (11).  
5 Sect: 7 mcl.
- KStN 1133 \*) Motorcycle Scout Platoon / Motorized Infantry Regiment**  
1.10.1937 Plt Hqs: 2 mcl; 1 car (medium).  
3 Inf Sqd: 3 mcl w/sc; 1 Infantry Squad with 1 LMG.
- KStN 202 Motorized Light Infantry Column**  
1.10.1937 Co Hqs: 2 mcl; 1 car (medium).  
Ammo Plt: 1 mcl w/sc; 13 trucks (light).  
Col Trains: 1 car (light); 3 trucks (light).
- KStN 1108 Headquarters, Motorized Infantry Battalion**  
1.10.1937 Bn Hqs: 5 mcl; 3 mcl w/sc; 1 car (11); 1 car (15).  
Signal Det: Hqs Sect: 1 car (15/2).  
2 Lt Tele Sect c: 1 car (15/2).  
2 Pack Radio Sect d: 1 car (2/2).  
2 Lt Armd Radio Sect d: 1 armored radio car (261).  
Maint Det: 1 mcl w/sc; 1 car (light); 2 trucks (light); 2 trucks (1.5-ton).  
Bn Trains: 3 mcl; 4 trucks (light); 1 truck (1.5-ton); 1 ambulance (31).
- KStN 1115 \*) Motorized Infantry Company**  
1.10.1937 Co Hqs: 3 mcl; 2 mcl w/sc; 1 car (15).  
3 Inf Plt: Hqs Sect: 1 mcl; 1 car (15).  
3 Inf Sqd: 2 trucks (70); 1 Infantry Squad with 2 LMG.  
1 Mortar Sect: 1 truck (70); 1 mortar (50mm).  
1 MG Plt: Hqs Sect: 1 mcl; 1 mcl w/sc; 1 car (15).  
1 Lt Tele Sect c: 1 car (15/1).  
2 HMG Det: 2 trucks (70); 2 HMG.  
Co Trains: 2 mcl; 1 car (15); 1 truck (light); 5 trucks (2-ton).
- KStN 1111a Motorcycle Infantry Company**  
1.10.1937 Co Hqs: 3 mcl; 1 mcl w/sc; 1 car (15); 1 car (18).  
3 Mcl Plt: Hqs Sect: 2 mcl; 1 car (11); 1 car (18).  
3 Mcl Sqd: 4 mcl w/sc; 1 Infantry Squad with 2 LMG.  
1 Mortar Sect: 2 mcl w/sc 1 mortar (50mm).  
1 MG Plt: Hqs Sect: 1 mcl; 2 mcl w/sc; 1 car (15); 1 car (18).  
1 Lt Tele Sect c: 1 car (15/2).  
MG Det: 14 mcl w/sc; 4 HMG.  
Co Trains: 2 mcl w/sc; 1 car (15); 1 truck (light); 5 trucks (1.5-ton).
- KStN 1121 Motorized Heavy Company**  
1.10.1937 Co Hqs: 2 mcl; 2 mcl w/sc; 1 car (11).  
Co Trains: 1 mcl; 2 mcl w/sc; 1 car (15); 5 trucks (1.5-ton); 1 truck (medium).
- KStN 1122 ATG Plt:**  
1.10.1937 Hqs Sect: 1 mcl; 1 mcl w/sc; 1 truck (69).  
Gun Det: 4 trucks (69); 3 ATG (37mm – towed); 1 LMG.
- KStN 1123 Lt IG Plt:**  
1.10.1937 Hqs Sect: 1 mcl; 2 mcl w/sc; 1 car (12).  
1 Lt Tele Sect c: 1 car (15/2).  
Gun Det: 3 trucks (69); 2 IG (75mm – towed); 1 trailer (ammo).
- KStN 1124 Engr Plt:**  
1.10.1937 Hqs Sect: 2 mcl; 1 mcl w/sc; 1 car (15).  
Engr Det: 1 mcl w/sc; 2 cars (15); 6 trucks (2-ton); 3 LMG.
- KStN 1126 Mortar Plt:**  
1.10.1938 Hqs Sect: 1 mcl w/sc; 1 car (11).  
3 Mortar Sect: 3 trucks (70); 2 mortars (81mm).

**NOTES:**

These KStN applied to the 4. Panzer-Division, the 5. Panzer-Division, the 2. leichte Division, the 4. leichte Division.

The 4. Panzer-Division's infantry regiment had a Motorcycle Scout Platoon.

The 5th Panzer-Division and the 4. leichte Division infantry regiments had Motorcycle Messenger Platoons.

The 2. leichte Division's infantry regiments did not have either type of motorcycle platoons.

See Order of Battle on page 35 for details regarding units.

**SCHÜTZEN-REGIMENT**  
**Motorized Infantry Regiment**

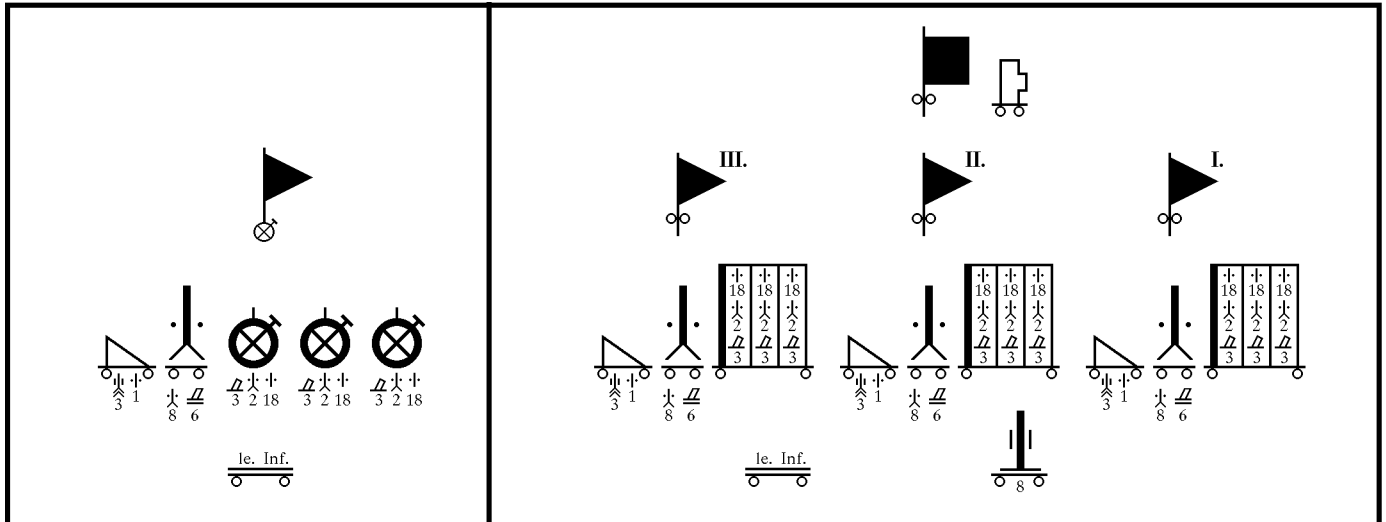

- KStN 1104 \*) Headquarters, Motorized Infantry Regiment**  
1.10.1937 Rgt Hqs: 5 mcl; 2 mcl w/sc; 2 cars (12).
- KStN 1197 \*) Signal Platoon, Motorized Infantry Regiment**  
1.03.1939 Plt Hqs: 1 mcl; 1 mcl w/sc; 1 cars (15/1); 2 cars (15/2).  
2 Lt Tele Sect c: 1 car (15/1).  
4 Pack Radio Sect d: ride in Platoon Headquarters vehicles.  
2 Lt Armored Radio Sect d: 1 radio armored car (261).
- KStN 202 Motorized Light Infantry Column**  
1.10.1937 Co Hqs: 2 mcl; 1 car (medium).  
Ammo Plt: 1 mcl w/sc; 13 trucks (light).  
Col Trains: 1 car (light); 3 trucks (light).
- KStN 1119 \*) Motorized Light Infantry Gun Company**  
1.10.1937 Co Hqs: 5 mcl; 2 mcl w/sc; 2 cars (15).  
4 Lt IG Plt: Hqs Sect: 1 mcl; 2 mcl w/sc; 1 car (12).  
1 Lt Tele Sect c: 1 car (15/2).  
Gun Det: 3 trucks (69); 2 IG (75mm – towed); 1 trailer (ammo).  
Co Trains: 2 mcl; 1 mcl w/sc; 1 car (15); 1 truck (light); 6 trucks (2-ton).
- KStN 1108 Headquarters, Motorized Infantry Battalion**  
1.10.1937 Bn Hqs: 5 mcl; 3 mcl w/sc; 1 car (11); 1 car (15).  
Signal Det: Hqs Sect: 1 car (15/2).  
2 Lt Tele Sect c: 1 car (15/2).  
2 Pack Radio Sect d: 1 car (2/2).  
2 Lt Armd Radio Sect d: 1 armored radio car (261).  
Maint Det: 1 mcl w/sc; 1 car (light); 2 trucks (light); 2 trucks (1.5-ton).  
Bn Trains: 3 mcl; 4 trucks (light); 1 truck (1.5-ton); 1 ambulance (31).
- KStN 1109 Headquarters, Independent Motorcycle Infantry Battalion**  
1.10.1937 Bn Hqs: 5 mcl; 3 mcl w/sc; 1 car (11); 1 car (15).  
Signal Det: Hqs Sect: 1 car (15/2).  
2 Lt Tele Sect c: 1 car (15/1).  
2 Pack Radio Sect b: 1 car (2/2).  
2 Lt Armd Radio Sect d: 1 armored radio car (261).  
Maint Det: 1 mcl w/sc; 1 car (light); 2 trucks (light); 2 trucks (1.5-ton).  
Bn Trains: 3 mcl; 2 cars (light); 3 trucks (light); 1 truck (1.5-ton); 1 ambulance (31).
- KStN 1113 Motorcycle Infantry Company**  
1.10.1937 Co Hqs: 3 mcl; 1 mcl w/sc; 1 car (15); 1 car (18).  
3 Mcl Plt: Hqs Sect: 2 mcl; 1 car (11); 1 car (18).  
3 Mcl Sqd: 4 mcl w/sc; 1 Infantry Squad with 2 LMG.  
1 Mortar Sect: 2 mcl w/sc; 1 mortar (50mm).  
MG Det: 10 mcl w/sc; 2 HMG.  
Co Trains: 2 mcl w/sc; 1 car (15); 1 truck (light); 5 trucks (1.5-ton).
- KStN 1112 \*) Motorized Infantry Company**  
1.10.1937 Co Hqs: 3 mcl; 2 mcl w/sc; 1 car (18).  
3 Inf Plt: Hqs Sect: 1 mcl; 1 car (15).  
3 Inf Sqd: 2 trucks (70); 1 Infantry Squad with 2 LMG.  
1 Mortar Sect: 1 truck (70); 1 mortar (50mm).  
HMG Det: 2 trucks (70); 2 HMG.  
Co Trains: 2 mcl; 1 car (15); 1 truck (light); 3 trucks (2-ton).
- KStN 1116 \*) Motorized Machine Gun Company**  
1.10.1937 Co Hqs: 3 mcl; 1 mcl w/sc; 1 car (18); 1 truck (70).  
2 MG Plt: Hqs Sect: 2 mcl; 1 car (11); 1 car (18).  
1 Lt Tele Sect c: 1 car (15/2).  
2 MG Det: 2 trucks (70); 2 HMG.  
1 Mortar Plt: Hqs Sect: 1 mcl w/sc; 1 car (11); 1 truck (70).  
3 Mortar Sect: 1 car (11); 2 trucks (70); 2 mortars (81mm).  
Co Trains: 2 mcl w/sc; 1 car (15); 1 truck (light); 5 trucks (1.5-ton).
- KStN 1122 Motorized Anti-Tank Platoon**  
1.10.1937 Hqs Sect: 1 mcl; 1 mcl w/sc; 1 truck (69).  
Gun Det: 4 trucks (69); 3 ATG (37mm – towed); 1 LMG.

**NOTES:**  
These KStN applied to the 1. leichte Division, the 3. leichte Division.

See Order of Battle on page 35 for for details regarding units.

**PANZER-ABWEHR-ABTEILUNG**  
**Motorized Anti-Tank Battalion**

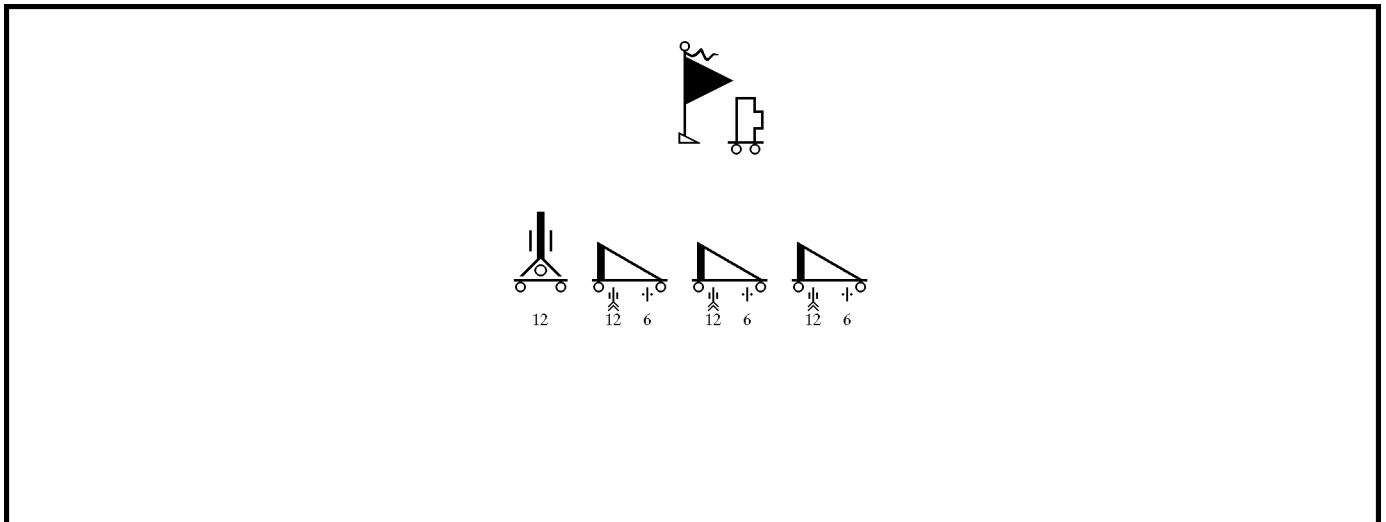

- KStN 1106 \*) Headquarters, Motorized Anti-Tank Battalion**  
1.10.1937  
Bn Hqs: 3 mcl; 2 mcl w/sc; 1 car (1); 1 car (12); 1 car (15).  
Bn Maint Det: 1 mcl w/sc; 1 car (light); 1 truck (light); 2 trucks (1.5-ton).  
Bn Trains: 3 mcl; 4 trucks (light).
- KStN 1192 \*) Motorized Signal Platoon, Motorized Anti-Tank Battalion**  
1.10.1937  
Plt Hqs: 2 mcl; 1 car (15/1).  
1 Lt Tele Sect c: 1 car (15/1).  
6 Pack Radio Sect b: 1 car (2/2).  
2 Lt Radio Sect b: 1 van (17).
- KStN 1141 \*) Motorized Anti-Tank Company "a"**  
1.10.1937  
Co Hqs: 3 mcl; 1 mcl w/sc; 1 car (15/1).  
3 ATG Plt: Hqs Sect: 1 mcl; 1 mcl w/sc; 1 car (12).  
MG & Ammo Sect: 2 trucks (69); 2 trailers (ammo); 2 LMG.  
Gun Det: 4 trucks (69); 4 ATG (37mm – towed).  
Co Trains: 1 mcl; 2 mcl w/sc; 1 car (light); 1 truck (light); 6 trucks (2-ton).
- KStN 1143 \*) Motorized Anti-Tank Company "b"**  
1.10.1937  
Co Hqs: 4 mcl; 1 car (12).  
3 ATG Plt: Hqs Sect: 1 mcl; 1 mcl w/sc; 1 car (12).  
MG Sect: 2 cars (12); 2 LMG.  
Ammo Sect: 4 cars (12); 4 trailers (ammo).  
Gun Det: 4 cars (12); 4 ATG (37mm – towed).  
Co Trains: 1 mcl; 2 mcl w/sc; 1 car (12); 1 truck (light); 3 trucks (3-ton).
- KStN 191 \*) Motorized Light Anti-Aircraft Company**  
1.10.1937  
Co Hqs: 4 mcl; 1 car (1); 1 car (15).  
Signal Det: Hqs Sect: 1 car (15/2).  
1 Lt Tele Sect c: 1 car (15/1).  
4 Pack Radio Sect d: 1 car (2/2).  
1 Lt Radio Sect c: 1 van (17/1).  
3 AA Plt: Hqs Sect: 1 car (15/1).  
Ammo Sect: 2 halftracks (10).  
Gun Det: 4 halftracks (10); 4 AA Guns (20mm – towed).  
Co Trains: 2 mcl; 1 mcl w/sc; 1 car (15); 2 trucks (light); 2 trucks (2-ton); 2 trucks (3-ton).

**Order of Battle – Anti-Tank Units**

Div.	Battalion	Anti-Tank Companies	Anti-Aircraft Company
1. Pz	37. Panzer-Abwehr-Abt.	3 "a"	2./59
2. Pz	38. Panzer-Abwehr-Abt.	3 "a"	–
3. Pz	39. Panzer-Abwehr-Abt.	3 "a"	6./59
4. Pz	79. Panzer-Abwehr-Abt.	2 "a"	5./66
5. Pz	(no battalion headquarters)	3 "a"	–
1. lei	41. Panzer-Abwehr-Abt.	3 "a"	3./46
2. lei	42. Panzer-Abwehr-Abt.	3 "b"	3./59
3. lei	43. Panzer-Abwehr-Abt.	3 "b"	4./48
4. lei	50. Panzer-Abwehr-Abt.	3 "b"	3./47

**NOTES:**

The Light Anti-Aircraft Company was designated in German both as "Maschinengewehr Kompanie (s)", (Machine Gun Company (heavy)) and as "Fliegerabwehr-MG-Kompanie" (Anti-Aircraft MG Company). These light anti-aircraft units (with KStN numbering in the 100's), were raised by the Infantry Inspectorate.

**ARTILLERIE-REGIMENT (motorisiert)**  
**Motorized Artillery Regiment**

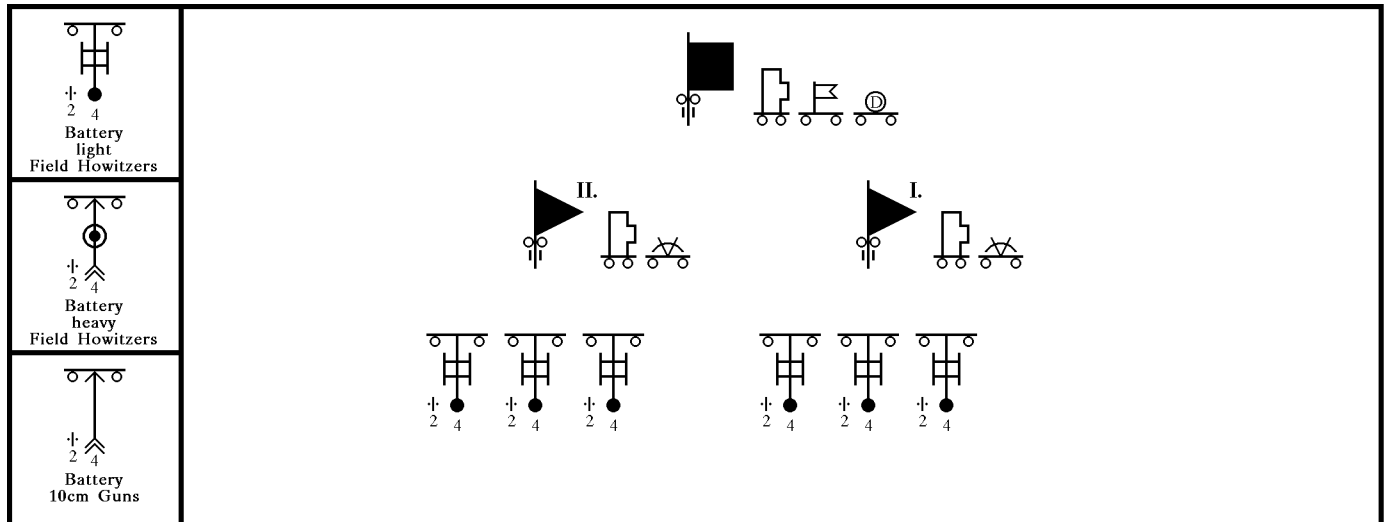

**KStN 411 \*)**  
1.10.1938

**Headquarters, Motorized Artillery Regiment**  
Rgt Hqs: 4 mcl; 1 car (1); 3 cars (15); 1 bus (medium).

**KStN 561 \*)**  
1.10.1937

**Signal Platoon, Motorized Artillery Regiment**  
Plt Hqs: 2 mcl; 1 car (15); 1 van (17/1).  
1 Hvy Tele Sect *b*: 1 car (2/1); 1 van (77).  
3 Lt Tele Sect *c*: 1 car (15/1).  
2 Lt Radio Sect *b*: 1 van (17).  
4 Pack Radio Sect *b*: 1 car (2/2).  
1 Lt Radio Sect *c*: 1 van (17/1).

**KStN 531**  
15.02.1932

**Motorized Meteorological Detachment**  
Det: 1 mcl; 1 van (62).

**KStN 527**  
1.12.1934

**Motorized Printing Detachment**  
Det: 1 mcl; 1 truck (3-ton); 1 van (62); 1 trailer (generator).

**Order of Battle – Artillery Units**

Div.	Artillerie Regiment	Battalion	Batteries			Battalion	Batteries		
1. Pz	72. Artillerie-Regiment (mot)	I.	1. le FH	2. le FH	3. le FH	II.	4. le FH	5. le FH	6. le FH
2. Pz	74. Artillerie-Regiment (mot)	I.	1. le FH	2. le FH	3. le FH	I/110	1. s FH	2. s FH	4. 10cm K
3. Pz	76. Artillerie-Regiment (mot)	I.	1. le FH	2. le FH	3. le FH	II.	4. le FH	5. le FH	6. le FH
4. Pz	103. Artillerie-Regiment (mot)	I.	1. le FH	2. le FH	3. le FH	II.	4. le FH	5. le FH	6. le FH
5. Pz	116. Artillerie-Regiment (mot)	I.	1. le FH	2. le FH	3. le FH	II.	4. le FH	5. le FH	7. le FH
1. lei	76. Artillerie-Regiment (mot)	I.	1. le FH	2. le FH	3. le FH	II.	4. le FH	5. le FH	6. le FH
2. lei	78. Artillerie-Regiment (mot)	I.	1. le FH	2. le FH	3. le FH	II.	4. le FH	5. le FH	6. le FH
3. lei	80. Artillerie-Regiment (mot)	I.	1. le FH	2. le FH	3. le FH	II.	4. le FH	5. le FH	6. le FH
4. lei	102. Artillerie-Regiment (mot)	I.	1. le FH	2. le FH	3. le FH	II.	4. le FH	5. le FH	6. le FH

**ARTILLERIE-REGIMENT (motorisiert)**  
**Motorized Artillery Regiment**

- KStN 413**      **Headquarters, Motorized Light Artillery Battalion**  
1.10.1937      Bn Hqs: 3 mcl; 2 mcl w/sc; 1 car (1); 1 car (12); 1 car (15).  
                  Bn Maint Det: 1 mcl w/sc; 1 car (light); 1 truck (light); 2 trucks (1.5-ton).  
                  Bn Trains: 3 mcl; 4 trucks (light).
- KStN 564**      **Motorized Signal Platoon, Motorized Light Artillery Battalion / Panzer-Division and light Division (mot)**  
1.10.1937      Plt Hqs: 3 mcl; 1 mcl w/sc; 1 car (light); 1 car (15); 1 car (15/2).  
                  1 Med Tele Sect *b*: 1 car (15/1); 1 van (76).  
                  1 Hvy Tele Sect *b*: 1 car (2/1); 1 van (77).  
                  2 Lt Tele Sect *c*: 1 car /15/1).  
                  3 Pack Radio Sect *b*: 1 car (2/2).  
                  3 Pack Radio Sect *b*: ride with other sections of the platoon.
- KStN 529 \*)**    **Motorized Calibration Detachment**  
15.02.1932      Det: 2 mcl; 1 car (3); 1 truck (1.5-ton).
- KStN 434**      **Motorized Light Field Howitzer Battery**  
1.10.1938      Bty Hqs : 3 mcl; 1 car (11); 1 car (12).  
                  Signal Det: Hqs Sect: 1 car (2/2).  
                          1 Hvy Tele Sect *a*: 1 car (2/2); 1 van (23).  
                          1 Med Tele Sect *b*: 1 car (15/1); 1 van (76).  
                          1 Pack Radio Sect *f*: 1 car (2/2).  
                          2 Pack Radio Sect *f*: ride with other sections of the platoon.  
                  Gun Plt: 2 mcl; 1 car (1); 1 AA car (4 w/dual MG); 2 cars (12); 4 halftracks (6/1); 4 light Field Howitzers (105mm – towed).  
                  1 Ammo Det: 2 mcl; 1 mcl w/sc; 4 trucks (2-ton).  
                  1 Ammo Det: 1 mcl; 4 trucks (2-ton); 4 trailers (ammo).  
                  Bty Trains: 1 mcl; 1 mcl w/sc; 3 trucks (light); 1 truck (medium); 1 halftrack (6/1).
- KStN 406 \*)**    **Headquarters, Motorized Heavy Artillery Battalion**  
1.10.1937      Bn Hqs: 3 mcl; 2 mcl w/sc; 1 car (1); 2 cars (15).  
                  Bn Maint Det: 1 mcl w/sc; 1 car (light); 1 truck (light); 2 trucks (1.5-ton).  
                  Bn Trains: 2 mcl; 1 mcl w/sc; 6 trucks (light).
- KStN 556**      **Motorized Signal Platoon, Motorized Heavy Artillery Battalion / Panzer-Division and light Division (mot)**  
1.10.1937      Plt Hqs: 3 mcl; 1 mcl w/sc; 1 car (light); 1 car (15); 1 car (15/2).  
                  1 Med Tele Sect *b*: 1 car (15/1); 1 van (76).  
                  1 Hvy Tele Sect *b*: 1 car (2/1); 1 van (77).  
                  2 Lt Tele Sect *c*: 1 car /15/1).  
                  6 Pack Radio Sect *b*: 1 car (2/2).  
                  1 Lt Radio Sect *c*: 1 van (17/1).
- KStN 529 \*)**    **Motorized Calibration Detachment**  
15.02.1932      Det: 2 mcl; 1 car (3); 1 truck (1.5-ton).
- KStN 462 \*)**    **Motorized Heavy Field Howitzer Battery**  
1.10.1938      Bty Hqs : 3 mcl; 1 car (11); 1 car (12).  
                  Signal Det: Hqs Sect: 1 car (2/2).  
                          1 Hvy Tele Sect *a*: 1 car (2/2); 1 van (23).  
                          1 Med Tele Sect *b*: 1 car (15/1); 1 van (76).  
                          1 Pack Radio Sect *f*: 1 car (2/2).  
                          2 Pack Radio Sect *f*: ride with other sections of the platoon.  
                  Gun Plt: 2 mcl; 1 car (1); 1 AA car (4 w/dual MG); 2 cars (12); 4 halftracks (7); 4 heavy Field Howitzers (150mm – towed).  
                  1 Ammo Det: 2 mcl; 1 mcl w/sc; 4 trucks (2-ton).  
                  1 Ammo Det: 1 mcl; 4 trucks (2-ton); 4 trailers (ammo).  
                  Bty Trains: 1 mcl; 1 mcl w/sc; 3 trucks (light); 1 truck (medium); 1 halftrack (7).
- KStN 454 \*)**    **Motorized 10cm Gun Battery**  
1.10.1938      Bty Hqs : 3 mcl; 1 car (11); 1 car (12).  
                  Signal Det: Hqs Sect: 1 car (2/2).  
                          1 Hvy Tele Sect *a*: 1 car (2/2); 1 van (23).  
                          1 Med Tele Sect *b*: 1 car (15/1); 1 van (76).  
                          1 Pack Radio Sect *f*: 1 car (2/2).  
                          2 Pack Radio Sect *f*: ride with other sections of the platoon.  
                  Gun Plt: 2 mcl; 1 car (1); 1 AA car (4 w/dual MG); 2 cars (12); 8 halftracks (7); four 105mm Gun in two loads, each – towed (barrel & cradle).  
                  1 Ammo Det: 2 mcl; 1 mcl w/sc; 4 trucks (2-ton).  
                  1 Ammo Det: 1 mcl; 4 trucks (2-ton); 4 trailers (ammo).  
                  Bty Trains: 1 mcl; 1 mcl w/sc; 3 trucks (light); 1 truck (medium); 1 halftrack (7).

**AUFKLÄRUNGS-REGIMENT (motorisiert) & AUFKLÄRUNGS-ABTEILUNG (motorisiert)**  
**Motorized Reconnaissance Regiment & Motorized Reconnaissance Battalion**

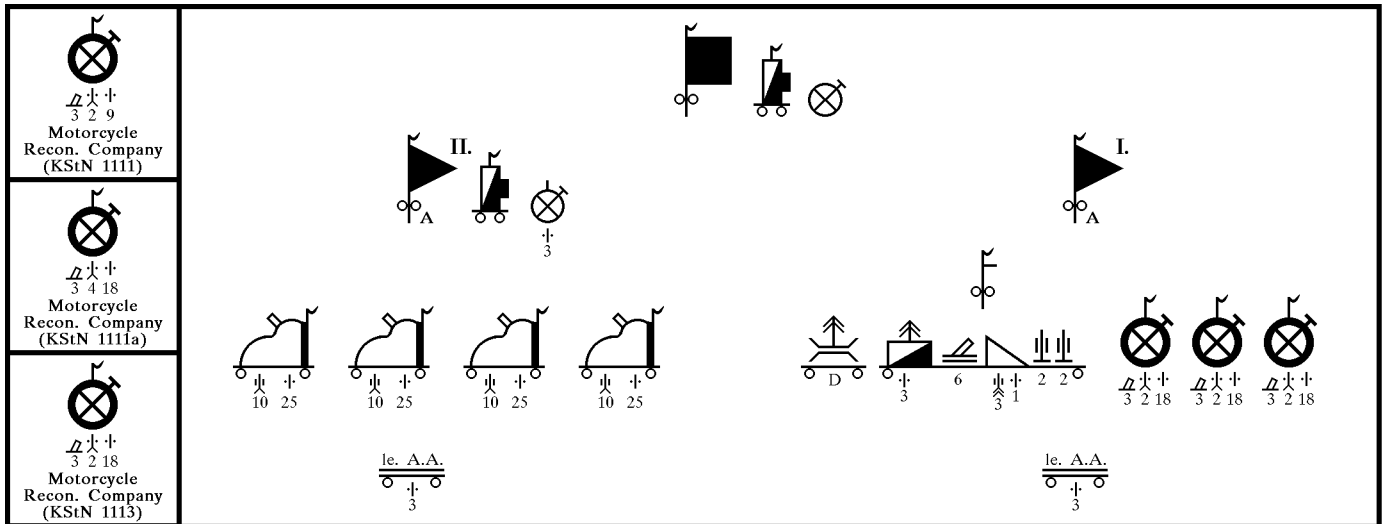

- KStN 1101**      **Headquarters, Motorized Reconnaissance Regiment**  
 1.10.1938      Rgt Hqs: 3 mcl; 2 mcl w/sc; 1 car (11); armored staff car (247).  
                     Rgt Hqs Trains: 2 mcl w/sc; 1 car (light); 1 car (15); 1 truck (light); 2 trucks (1.5-ton).
- KStN 1189**      **Signal Platoon, Motorized Reconnaissance Regiment**  
 1.10.1937      Plt Hqs: 2 mcl w/sc; 1 car (15).  
                     1 Lt Tele Sect c: 1 car (15/1).  
                     1 Hvy Tele Sect b: 1 car (2/1); 1 van (77).  
                     3 Med Radio Sect b: 1 car (15/6); 1 van (17/3).
- KStN 1067 \*)**      **Motorcycle Messenger Platoon**  
 1.10.1937      Plt Hqs: 3 mcl; 1 mcl w/sc; 1 car (11).  
                     5 Sect: 7 mcl.

**Order of Battle – Motorized Reconnaissance Regiments and Battalions**

Div.	Regiment	Regimental Units	Battalion (with KStN)	Battalion Units	Companies (with KStN)		Heavy Company Platoons				
					Armored Car	Motorcycle	1 ATG	1 IG	1 Engr	–	Bridge D
1. Pz	–	–	4. Aufklärungs-Abt. (1105)	Signal Plt	2	1 (1111)	1 ATG	1 IG	1 Engr	–	Bridge D
2. Pz	–	–	5. Aufklärungs-Abt. (1105)	Signal Plt + Mcl Plt	2	1 (1111)	1 ATG	1 IG	1 Engr	–	–
3. Pz	–	–	3. Aufklärungs-Abt. (1105)	Signal Plt	2	1 (1111)	1 ATG	1 IG	1 Engr	–	Bridge D
4. Pz	–	–	7. Aufklärungs-Abt. (1105)	Signal Plt	2	1 (1111a)	1 ATG	1 IG	1 Engr	–	Bridge D
5. Pz	–	–	8. Aufklärungs-Abt. (1105)	Signal Plt	2	1 (1111a)	–	2IG	1 Engr	–	–
1. lei	–	–	1. Aufklärungs-Abt. (1105)	Signal Plt + Mcl Plt	2	1 (1113)	1 ATG	1 IG	1 Engr	–	–
2. lei	7.	Signal Plt + Mcl Plt	I. Kradschützen-Abt. (1108)	–	–	3 (1113)	1 ATG	2IG	1 Engr	1 Mortar	Bridge D
			II. Panzerspäh-Abt. (1105)	Signal Plt	4	–	–	–	–	–	–
3. lei	8.	Signal Plt + Mcl Plt	I. Aufklärungs-Abt. (1105)	Signal Plt	2	1 (1113)	1 ATG	1 IG	1 Engr	–	–
			II. Aufklärungs-Abt. (1105)	Signal Plt	2	1 (1113)	1 ATG	1 IG	1 Engr	–	–
4. lei	9.	Signal Plt + Mcl Plt	I. Kradschützen-Abt. (1108)	–	–	3 (1111a)	1 ATG	2IG	1 Engr	1 Mortar	Bridge D
			II. Panzerspäh-Abt. (1105)	Signal Plt	3	–	–	–	–	–	–

**Note on German Motorized Reconnaissance Designations in 1939:**  
 All company echelon units of all reconnaissance battalions and regiments were designated as “Schwadron”, (British Army designation would be Squadron; US Army designation would be Troop), not “Kompanie” (Company). The prefix “Panzer-” for the battalions was not used until 1.04.1940.

**AUFKLÄRUNGS-REGIMENT (motorisiert) & AUFKLÄRUNGS-ABTEILUNG (motorisiert)**  
**Motorized Reconnaissance Regiment & Motorized Reconnaissance Battalion**

- KStN 1108**  
1.10.1937 **Headquarters, Motorcycle Reconnaissance Battalion / Motorized Reconnaissance Regiment**  
 Bn Hqs: 5 mcl; 3 mcl w/sc; 1 car (11); 1 car (15).  
 Signal Det: Hqs Sect: 1 car (15/2).  
                   2 Lt Tele Sect c: 1 car (15/2).  
                   2 Pack Radio Sect d: 1 car (2/2).  
                   2 Lt Radio Sect d: 1 van (17/2).  
 Maint Det: 1 mcl w/sc; 1 car (light); 2 trucks (light); 2 trucks (1.5-ton).  
 Bn Trains: 3 mcl; 4 trucks (light); 1 truck (1.5-ton); 1 ambulance (31).
- KStN 1133 \***  
1.03.1939 **Motorcycle Scout Platoon / Motorcycle Reconnaissance Battalion**  
 Plt Hqs: 2 mcl; 1 car (11); 1 car (18).  
 3 Inf Sqd: 4 mcl w/sc; 1 Infantry Squad with 1 LMG.
- KStN 1181**  
1.10.1937 **Motorized Light Reconnaissance Column / Motorcycle Reconnaissance Battalion**  
 Col Hqs: 3 mcl; 4 mcl w/sc; 1 car (15); 3 LMG.  
 1 Sect: 1 mcl; 5 trucks (2-ton).  
 2 Sect: 4 trucks (medium).  
 Col Trains: 1 mcl w/sc; 2 trucks (light).
- KStN 1111**  
1.10.1937 **Motorcycle Reconnaissance Company**  
 Co Hqs: 3 mcl; 1 mcl w/sc; 1 car (11); 1 car (15).  
 3 Mcl Plt: Hqs Sect: 2 mcl; 1 car (11); 1 car (18).  
                   3 Mcl Sqd: 3 mcl w/sc; 1 Reconnaissance Squad with 1 LMG.  
                   1 Mortar Sect: 2 mcl w/sc; 1 mortar (50mm).  
 MG Det: 10 mcl w/sc; 2 HMG.  
 Co Trains: 2 mcl w/sc; 1 car (15); 1 truck (light); 5 trucks (1.5-ton).
- KStN 1111a**  
1.10.1937 **Motorcycle Reconnaissance Company**  
 Co Hqs: 3 mcl; 1 mcl w/sc; 1 car (15); 1 car (18).  
 3 Mcl Plt: Hqs Sect: 2 mcl; 1 car (11); 1 car (18).  
                   3 Mcl Sqd: 4 mcl w/sc; 1 Reconnaissance Squad with 2 LMG.  
                   1 Mortar Sect: 2 mcl w/sc; 1 mortar (50mm).  
 1 MG Plt: Hqs Sect: 1 mcl; 2 mcl w/sc; 1 car (15); 1 car (18).  
                   1 Lt Tele Sect c: 1 car (15/2).  
                   MG Det: 14 mcl w/sc; 4 HMG.  
 Co Trains: 2 mcl w/sc; 1 car (15); 1 truck (light); 5 trucks (1.5-ton).
- KStN 1113**  
1.10.1937 **Motorcycle Reconnaissance Company**  
 Co Hqs: 3 mcl; 1 mcl w/sc; 1 car (15); 1 car (18).  
 3 Mcl Plt: Hqs Sect: 2 mcl; 1 car (11); 1 car (18).  
                   3 Mcl Sqd: 4 mcl w/sc; 1 Reconnaissance Squad with 2 LMG.  
                   1 Mortar Sect: 2 mcl w/sc; 1 mortar (50mm).  
 MG Det: 10 mcl w/sc; 2 HMG.  
 Co Trains: 2 mcl w/sc; 1 car (15); 1 truck (light); 5 trucks (1.5-ton).
- KStN 1105**  
1.10.1937 **Headquarters, Motorized Reconnaissance Battalion**  
 Bn Hqs: 2 mcl; 3 mcl w/sc; 1 car (11); 1 car (15); 1 armored staff car (247).  
 Bn Trains: 1 mcl w/sc; 1 car (1); 2 cars (15); 4 trucks (light); 5 trucks (1.5-ton); 1 ambulance (31).
- KStN 1191**  
1.10.1938 **Motorized Signal Platoon / Motorized Reconnaissance Battalion**  
 Plt Hqs: 1 mcl; 2 mcl w/sc; 1 car (15).  
                   2 Lt Tele Sect c: 1 car (15/2).  
                   2 Pack Radio Sect d: 1 car (2/2).  
                   2 Med Armd Radio Sect b: 1 car (15/2); 1 armored radio car (263).  
                   4 Lt Armd Radio Sect d: 1 armored radio car (261).  
                   1 Lt Armd Radio Sect c: 1 armored radio car (260).  
 Personnel Replacement Det: 1 truck (1.5-ton).
- KStN 1133 \***  
1.03.1939 **Motorcycle Scout Platoon / Motorized Reconnaissance Battalion**  
 Plt Hqs: 2 mcl; 1 car (11); 1 car (18).  
 3 Inf Sqd: 4 mcl w/sc; 1 Infantry Squad with 1 LMG.
- KStN 1181**  
1.10.1937 **Motorized Light Reconnaissance Column / Motorized Reconnaissance Battalion**  
 Col Hqs: 3 mcl; 4 mcl w/sc; 1 car (15); 3 LMG.  
 1 Sect: 1 mcl; 5 trucks (2-ton).  
 2 Sect: 4 trucks (medium).  
 Col Trains: 1 mcl w/sc; 2 trucks (light).
- KStN 1162**  
1.10.1938 **Armored Car Company**  
 Co Hqs: 6 mcl; 6 mcl w/sc; 1 car (11); 1 armored staff car (247).  
 1 Signal Det: 4 armored radio cars (223).  
 1 Med Armd Radio Sect b: 1 car (15/2); 1 armored radio car (263).  
 1 Hvy Armored Car Plt: 3 armored cars (231); 3 armored radio cars (232).  
 1 Lt Armored Car Plt: 6 armored cars (221).  
 1 Lt Armored Car Plt: 4 armored cars (221); 4 armored cars (222).  
 Co Trains: 2 mcl w/sc; 1 car (15); 1 truck (light); 7 trucks (2-ton).
- KStN 1121**  
1.10.1937 **Motorized Heavy Company**  
 Co Hqs: 2 mcl; 2 mcl w/sc; 1 car (11).  
 Co Trains: 1 mcl; 2 mcl w/sc; 1 car (light); 1 car (15); 7 trucks (2-ton); 1 truck (medium).
- KStN 1122**  
1.10.1937 **Motorized Heavy Company**  
 ATG Plt: Hqs Sect: 1 mcl; 1 mcl w/sc; 1 truck (69).  
                   Gun Det: 4 trucks (69); 3 ATG (37mm – towed); 1 LMG.
- KStN 1123**  
1.10.1937 **Motorized Heavy Company**  
 Lt IG Plt: Hqs Sect: 1 mcl; 2 mcl w/sc; 1 car (12).  
                   1 Lt Tele Sect c: 1 car (15/2).  
                   Gun Det: 3 trucks (69); 2 IG (75mm – towed); 1 trailer (ammo).
- KStN 1126**  
1.10.1938 **Motorized Heavy Company**  
 Mortar Plt: Hqs Sect: 1 mcl w/sc; 1 car (11).  
                   3 Mortar Sect: 3 trucks (70); 2 mortars (81mm).
- KStN 1124**  
1.10.1937 **Motorized Heavy Company**  
 Engr Plt: Hqs Sect: 2 mcl; 1 mcl w/sc; 1 car (15).  
                   Engr Det: 1 mcl w/sc; 2 cars (15); 6 trucks (2-ton); 3 LMG.  
 Type D Bridge Det: 1 mcl; 7 trucks (3-ton).
- (AHM 3596/39**  
dated 11.08.1939)

**PIONIER-BATAILLON (motorisiert)**  
**Motorized Combat Engineer Battalion**

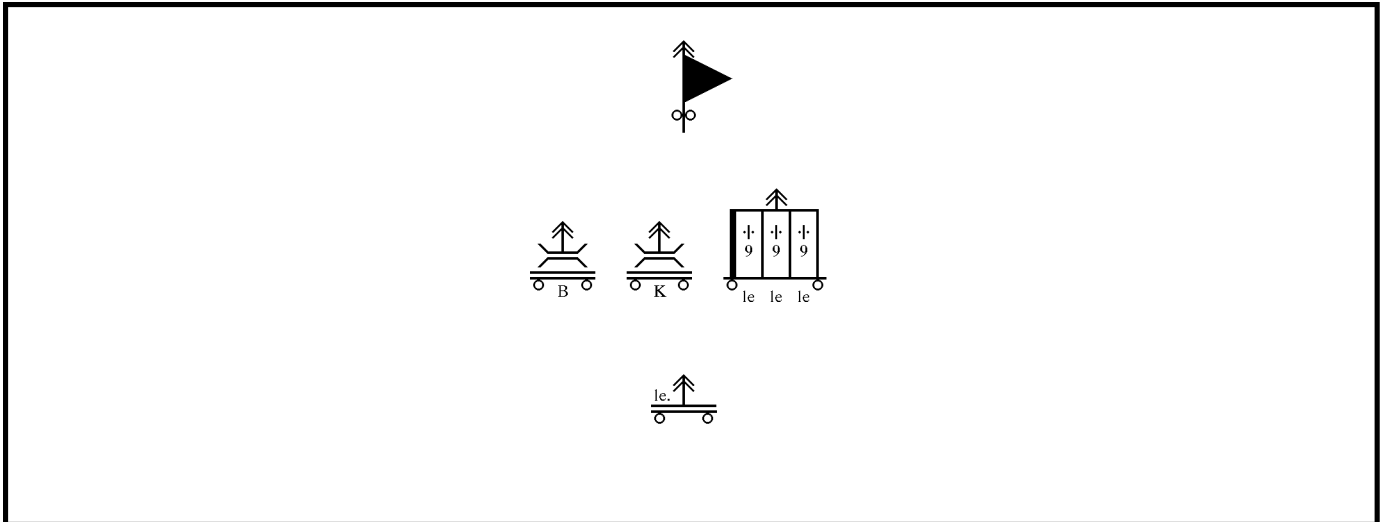

**KStN 703**  
1.10.1937

**Headquarters, Motorized Combat Engineer Battalion**

Bn Hqs: 3 mcl; 2 mcl w/sc; 1 car (11); 2 cars (15).  
 Signal Det: Hqs Sect: 1 mcl w/sc.  
                   2 Pack Radio Sect *b*: 1 car (2).  
                   2 Pack Radio Sect *b*: ride together in 1 truck (2-ton).  
 Bn Hqs Trains: 2 mcl; 2 trucks (light).

**KStN 742**  
1.10.1938(?)

**Motorized Light Engineer Column / Motorized Combat Engineer Battalion / Panzer Division**

Col Hqs: 1 mcl; 1 mcl w/sc; 1 car (light).  
 1 Plt: 1 mcl; 1 mcl w/sc; 8 trucks (medium); 1 trailer (2-wheel – compressor); 1 trailer (4-wheel – cargo).  
 1 Plt: 1 mcl; 1 mcl w/sc; 7 trucks (medium); 1 ambulance (31); 2 trailers (4-wheel – cargo).  
 Col Trains: 1 mcl ; 2 trucks (light).

**KStN 714**  
1.10.1938

**Motorized Light Combat Engineer Company**

Co Hqs: 3 mcl; 1 mcl w/sc; 1 car (15); 1 truck (2-ton).  
 2 Pack Radio Sect *b*: 1 car (15).  
 3 Engr Plt: Hqs Sect: 1 mcl; 1 mcl w/sc; 1 car (15).  
                   2 Engr Sect: 1 car (2); 2 trucks (2-ton); 1 Combat Engineer Section with 1 LMG.  
                   1 Engr Sect: 1 mcl; 1 mcl w/sc; ; 2 trucks (2-ton); 1 Combat Engineer Section with 1 LMG.  
 Co Trains: 2 mcl; 2 trucks (light); 1 truck (medium); 3 trucks (3-ton).

**KStN 733**  
1.10.1937

**Motorized Type B Bridge Column**

Col Hqs: 3 mcl; 1 car (1).  
 2 Bridge Plt: Hqs Sect: 1 mcl; 1 car (light).  
                   Trestle Sect: 4 halftracks (7); 4 trailers (4-wheel w/ trestles)  
                   Pontoon Sect: 8 trucks (3-ton); 8 trailers (4-wheel w/ 3 pontoons each).  
                   Boat Sect: 1 truck (3-ton); 1 trailer (4-wheel w/ motor boat).  
 1 Support Plt: 2 mcl w/sc; 1 truck (light); 1 truck (medium); 3 trucks (3-ton); 1 trailer (2-wheel w/ winch); 2 trailers (4-wheel w/ ramps).  
 Col Trains: 1 truck (light).

**KStN 737**  
1.10.1937

**Motorized Type K Bridge Column**

Col Hqs: 3 mcl; 1 car (light).  
 2 Bridge Plt: Hqs Sect: 1 mcl; 1 mcl w/sc.  
                   Pontoon Sect: 4 trucks (3-ton).  
                   Trestle Sect: 4 trucks (3-ton).  
                   Beam Sect: 4 trucks (3-ton).  
 1 Support Plt: 2 mcl w/sc, 2 trucks (light); 4 trucks (3-ton).  
 Col Trains: 1 truck (light).

**Order of Battle – Motorized Combat Engineer Units**

Div.	Battalion	Combat Engineer Companies	Bridge Columns
1. Pz	37. Pionier-Btl.	3	2 B + 1 K
2. Pz	38. Pionier-Btl.	3	2 B + 1 K
3. Pz	39. Pionier-Btl.	3	2 B + 1 K
4. Pz	(no battalion headquarters)	1	K
5. Pz	89. Pionier-Btl.	2	1 B + 1 K
1. lei	57. Pionier-Btl.	2	B
2. lei	58. Pionier-Btl.	2	B
3. lei	59. Pionier-Btl.	2	B
4. lei	86. Pionier-Btl.	2	B



**NACHRICHTEN-ABTEILUNG (motorisiert) & NACHRICHTEN-KOMPANIE (motorisiert)**  
**Motorized Signal Battalion & Motorized Signal Company**

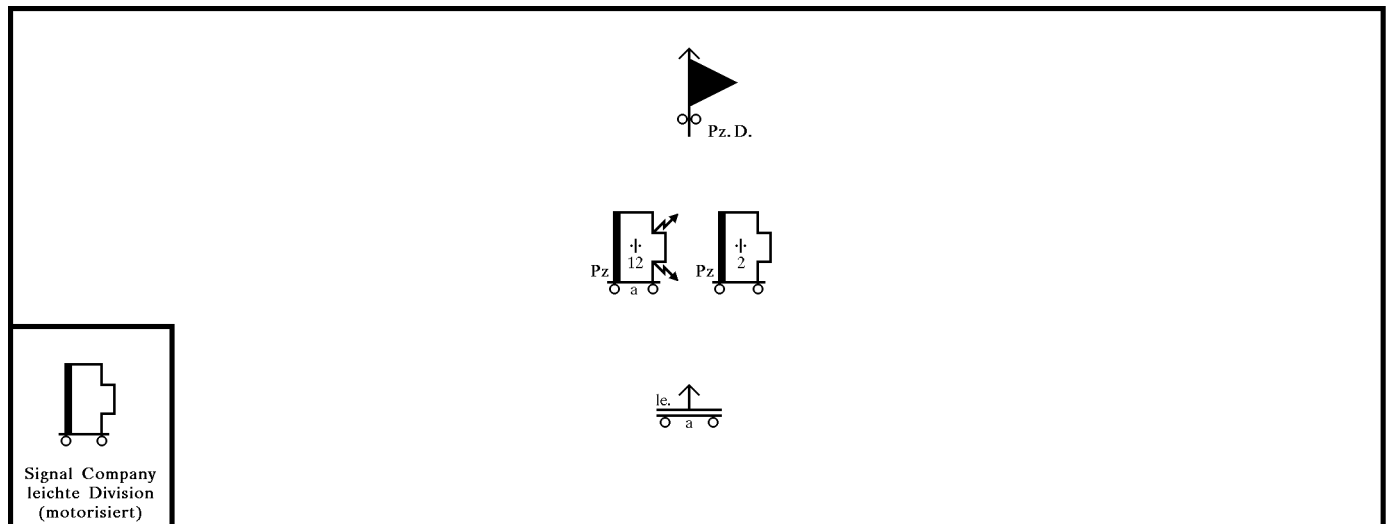

- KStN 807**      **Headquarters, Motorized Divisional Signal Battalion**  
 1.10.1937      Bn Hqs: 2 mcl; 3 cars (15); 2 trucks (1.5-ton).
- KStN 991**      **Motorized Light Signal Column "a" / Panzer Division Signal Battalion**  
 1.10.1937      Col: 1 mcl w/sc; 1 car (light); 1 van (light); 4 trucks (light); 1 truck (medium); 2 vans (42); 1 trailer (generator).
- KStN 971**      **Armored Radio Company "a"**  
 1.10.1937      Co Hqs: 2 mcl; 1 mcl w/sc; 2 cars (15); 1 truck (2-ton).  
 1st Plt:      Hqs Sect: 2 mcl, 1 car (15).  
                  Signal Det: 3 Pz-Bef-III (267); 1 Pz-Bef-III (266).  
                  1 Lt Armd Radio Sect c: 1 radio armored car (260).  
                  6 Lt Armd Radio Sect d: 1 radio armored car (261).  
 2nd Plt:      Hqs Sect: 2 mcl, 1 car (15).  
                  6 Med Armd Radio Sect b: 1 car (15/6); 1 armored radio car (263).  
 3rd Plt:      Hqs Sect: 2 mcl, 1 car (15).  
                  Signal Det: 2 Pz-Bef-III (267); 1 Pz-Bef-III (268).  
                  1 Lt Armd Radio Sect c: 1 radio armored car (260).  
 Personnel Reserve Det: 1 mcl; 1 car (2); 3 trucks (2-ton).  
 Co Trains: 2 mcl; 6 trucks (light); 1 van (42); 1 trailer (generator).
- KStN 981**      **Armored Signal Company**  
 1.10.1937      Co Hqs: 2 mcl; 1 mcl w/sc; 2 cars (15); 1 truck (2-ton).  
 1st Plt:      Hqs Sect: 2 mcl; 1 car (15).  
                  1 Med Armd Radio Sect b: 1 car (15/6); 1 armored radio car (263).  
                  1 Tele Ops Sect a: 1 car (15/1); 1 van (17).  
                  2 Lt Tele Sect b: 1 car (15/1).  
                  1 Hvy Tele Sect b: 1 car /2/1; 1 van (77).  
 2nd Plt:      Hqs Sect: 2 mcl; 1 car (15).  
                  4 Hvy Tele Sect b: 1 car /2/1; 1 van (77).  
 3rd Plt:      Hqs Sect: 2 mcl; 1 car (15).  
                  1 Med Armd Radio Sect b: 1 car (15/6); 1 armored radio car (263).  
                  4 Lt Armd Radio Sect d: 1 radio armored car (261).  
                  1 Tele Ops Sect a: 1 car (15/1); 1 van (17).  
                  1 Hvy Tele Sect b: 1 car (2/1); 1 van (77).  
                  4 Lt Tele Sect b: 1 car (15/1).  
 Personnel Reserve Det: 1 mcl; 1 car (2); 1 truck (2-ton).  
 Co Trains: 2 mcl; 5 trucks (light); 1 van (42); 1 trailer (generator).
- KStN 947 \***      **Motorized Signal Company / leichte Division (motorisiert)**  
 1.10.1937      Co Hqs: 2 mcl; 1 mcl w/sc; 2 cars (15); 1 truck (2-ton).  
 1 Tele Plt: Hqs Sect: 2 mcl; 1 car (15).  
                  2 Tele Ops Sect a: 1 car (15/1); 1 van (17).  
                  1 Tele Ops Sect a: 1 car (15/1); 1 van (17).  
                  4 Lt Tele Sect b: 1 car (15/1).  
                  2 Hvy Tele Sect b: 1 car /2/1; 1 van (77).  
 3 Radio Plt: Hqs Sect: 2 mcl; 1 car (15).  
                  2 Med Radio Sect b: 1 car (2/1); 1 van (77).  
                  4 Lt Tele Sect b: 1 car (15/1).  
 Personnel Reserve Det: 1 mcl; 1 car (2); 1 truck (2-ton).  
 Co Trains: 2 mcl; 6 trucks (light); 1 van (42); 1 trailer (generator).

**NOTES:**

The 1st Platoon, Armored Radio Company was attached to the Divisional Headquarters.

The 2nd Platoon, Armored Signal Company, plus 1 Light Armored Radio Section of the Armored Radio Company were attached to the highest infantry echelon.

The 3rd Platoon, Armored Radio Company, plus 2 Light Telephone Sections of the Armored Signal Company were attached to the highest Panzer echelon.

**DIVISIONS VERSORGUNGSDIENSTE**  
**Divisional Support Services**

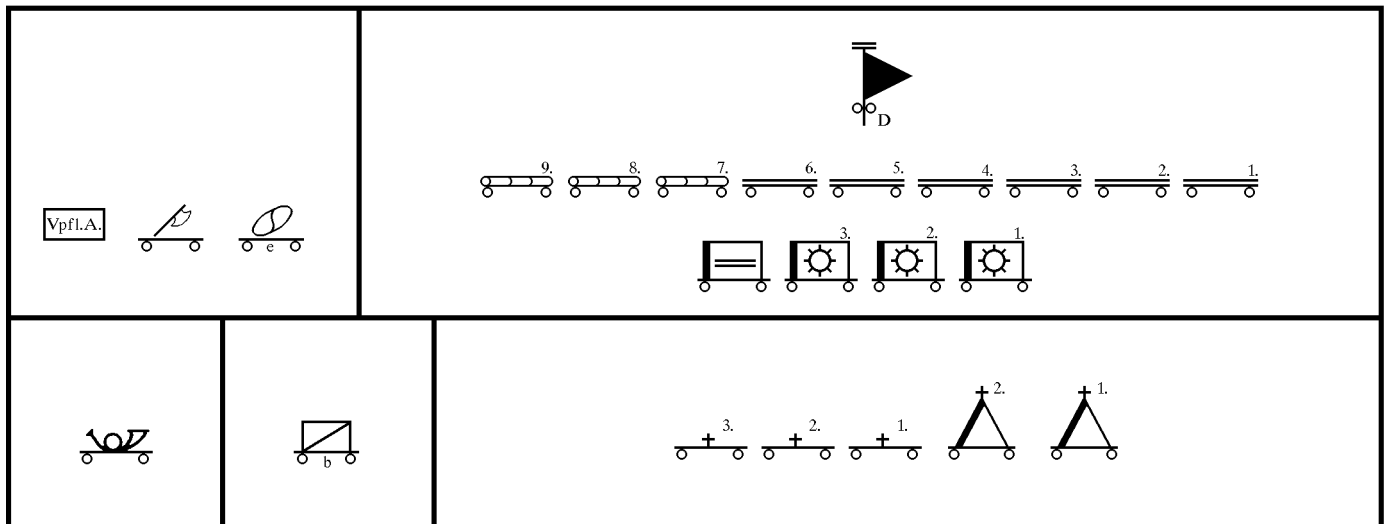

- KStN 1208 \*) Chief of Divisional Supply Services (mot)**  
1.03.1939  
Bn Hqs: 3 mcl; 1 mcl w/Sc; 2 cars (light); 1 car (medium); 1 car (11); 1 motor bus (light/11 seats).  
Commissary Det: 1 mcl; 1 car (light); 2 trucks (light); 2 trucks (medium).  
Ammunition Det: 1 mcl; 1 car (light); 1 motor bus (light/11 seats).  
Fuel Det: 1 mcl; 1 car (light); 2 trucks (light); 2 trucks (medium).  
Bn Maint Det: 1 mcl w/sc; 1 car (2/40); 1 car (light); 2 trucks (3-ton).
- KStN 1225 Motorized Transport Column (30 tons)**  
1.10.1937  
Col Hqs: 1 mcl; 1 mcl w/sc; 2 cars (light).  
2 Sect: 5 trucks (medium).  
1 Sect: 1 mcl w/sc; 1 truck (light).
- KStN 1226 Motorized Fuel Transport Column (25 m<sup>3</sup>)**  
1.10.1937  
Col Hqs: 1 mcl; 1 mcl w/sc; 1 car (light).  
2 Sect: 5 trucks (medium).  
1 Sect: 1 mcl w/sc; 1 truck (light).
- KStN 1052 Motorized Motor Maintenance Company**  
1.10.1937  
Co Hqs: 1 mcl; 1 car (light).  
2 Maint Plt: 1 mcl w/sc; 1 car (light); 1 truck (light); 1 truck (heavy); 1 bus (medium/31 seats); 1 van (79); 1 halftrack (7);  
1 trailer (cargo); 1 trailer (tool).  
1 Armorer Plt: 2 mcl w/sc; 1 truck (2-ton); 4 trucks (medium).  
Co Trains: 1 mcl w/sc; 1 car (light); 2 trucks (light).
- KStN 1255 Motorized Supply Company**  
1.10.1937  
Co Hqs: 2 mcl w/sc; 1 car (light); 1 truck (light).  
3 Supply Plt: 1 mcl w/sc; 3 trucks (medium).  
1 Technical Plt: 1 mcl w/sc; 3 trucks (medium).  
Co Trains: 1 mcl; 1 truck (light).

**NOTES:**

The divisional supply and support services were under Quartermaster Section (*Quartiermeisterabteilung*) in the Division Headquarters, headed up by the "Ib" Staff Officer = Division Quartermaster General. Excluding the supply battalion, these units were not grouped under a battalion or regiment headquarters.

The "Ib"'s staff consisted of:

- "Ib/WuG" Staff Officer = Division Arms and Equipment Officer
- "Ib/Kfz" Staff Officer = Division Motor Vehicle Officer
- "IVa" Staff Officer = Division Commissariat Officer
- "IVb" Staff Officer = Division Surgeon
- "IVc" Staff Officer = Division Veterinarian Doctor
- "IVd" Staff Officer = Division Chaplain
- "IVz" Staff Officer = Division Paymaster
- Field Post Master (*Feldpostmeister*)  
also Chief of the Divisional Field Post Detachment (mot), see below.
- Chief of Divisional Supply Services (*Dinasti*)  
also the Commanding Officer, Supply Battalion (with about half of his staff).

The two units indicated above:

- Divisional Field Post Detachment (*Feldpostamt*)
- Divisional Supply Battalion *Nachschub-Abteilung*, who also commanded all the unit trains of the division, with the other half of the staff

Division Commissariat Officer (*IVa*) had directly under him:

- Division Rations Administration Detachment (mot)
- Bakery Company (mot)
- Butchery Company (mot)

Division Surgeon (*IVb*) had directly under him:

- Medic Companies
- Ambulance Platoons (mot)
- All medical services and personnel of the division

Division Veterinary Doctor (*IVc*) had directly under him:

- Veterinary Company
- All veterinary services and personnel of the division

**DIVISIONS VERSORGUNGSDIENSTE**  
**Divisional Support Services**

- KStN 2086**  
1.02.1937      **Motorized Divisional Rations Administration Detachment**  
Det: 1 mcl; 1 car (light); 3 trucks (medium); 1 bicycle.
- KStN 1282 \*)**  
1.10.1938      **Motorized Butchery Platoon**  
Co Hqs: 1 mcl; 1 mcl w/sc; 1 car (light).  
2 Plt: 3 trucks (medium); 1 trailer (generator).  
Co Trains: 1 mcl w/sc; 1 car (light); 3 trucks (light).
- KStN 1277 \*)**  
1.10.1937      **Motorized Bakery Company "e"**  
Co Hqs: 1 mcl; 1 car (light).  
2 Plt: 3 trucks (heavy); 1 truck (heavy – water); 1 bus (medium/33 seats); 1 trailer (dough mixer); 2 trailers (oven).  
Co Trains: 1 mcl w/sc; 1 car (light); 3 trucks (light).
- KStN 1313**  
1.10.1937      **Motorized Medical Company**  
Co Hqs: 1 mcl; 1 mcl w/sc; 2 cars (15); 1 truck (light); 1 bus.  
2 Lt Radio Sect a: ride in company headquarters light truck.  
2 Medical Plt: 1 mcl w/sc; 1 car (11); 5 truck (medium); 1 van (medium); 5 ambulances (31).
- KStN 1365 \*)**  
1.10.1937      **Motorized Ambulance Platoon**  
Plt Hqs: 1 car (light); 2 trucks (light).  
3 Sect: 5 ambulances (31).
- KStN 2033b \*)**  
1.10.1938      **Motorized Military Police Detachment "b"**  
Det: 12 mcl; 4 mcl w/sc; 14 cars (light); 1 truck (light).
- KStN 2251**  
1.04.1935      **Motorized Field Post Detachment**  
Det: 1 car (medium); 2 vans (light); 1 motor bus (medium).

**NOTES:**

The Panzer-Division each had six and the leichte Division (motorisiert) each had five Motorized Transport Columns. The 1. Panzer-Division had seven Motorized Transport Columns.

## 2. Infantry Division (motorized)

Activated 15.10.1935  
 Mobilized 18.08.1939  
 Home Garrison II. Wehrkreis  
 Status on 1.09.1939

Assigned to XIX. Armeekorps (mot), 4. Armee, Heeresgruppe Nord  
 Commanding General Generalmajor (US equivalent is Brigadier General □ )  
 Paul Bader

## Authorized Strength in accordance with the Mobilization Plan 1939/1940

	Division Total	Division Headquarters	Infantry Regiments <sup>4</sup>	Artillery Regiment	Recon Battalion	Anti-Tank Battalion	Engineer Battalion	Signal Battalion	Support Services
Officers	492	17	246	106	15	22	22	4	50
Government Service Officials	133	14	33	14	3	3	2	3	61
Non-Commissioned Officers	2,456	26	1,467	372	58	132	91	74	236
Enlisted Men	13,364	106	7,572	2,345	310	551	716	333	1,431
<b>Total</b>	<b>16,445</b>	<b>163</b>	<b>9,318</b>	<b>2,837</b>	<b>386</b>	<b>708</b>	<b>831</b>	<b>424</b>	<b>1,778</b>
Pistols	4,142	49	2,538	479	162	259	142	28	485
Rifles	11,931	110	6,780	2,358	224	449	689	396	925
Sub-Machine Guns	31	–	–	–	31	–	–	–	–
Light Machine Guns <sup>1</sup>	374	–	264	30	35	18	27	–	–
Heavy Machine Guns	130	2	126	–	2	–	–	–	–
20mm AA Guns	12	–	–	–	–	12	–	–	–
37mm AT Guns	72	–	36	–	–	36	–	–	–
light (50mm) Mortars	84	–	81	–	3	–	–	–	–
heavy (81mm) Mortars	54	–	54	–	–	–	–	–	–
light (75mm) Infantry Guns	24	–	24	–	–	–	–	–	–
heavy (150mm) Infantry Guns	–	–	–	–	–	–	–	–	–
light (105mm) Field Howitzers	36	–	–	36	–	–	–	–	–
heavy (105mm) Guns	–	–	–	–	–	–	–	–	–
heavy (150mm) Field Howitzers	12	–	–	12	–	–	–	–	–
20mm AFV Guns	10	–	–	–	10	–	–	–	–
37mm AFV Guns	–	–	–	–	–	–	–	–	–
75mm AFV Guns	–	–	–	–	–	–	–	–	–
Gun Tanks	–	–	–	–	–	–	–	–	–
Other Tanks <sup>2</sup>	–	–	–	–	–	–	–	–	–
Armored Cars <sup>3</sup>	30	–	–	–	30	–	–	–	–
<b>Total AFV</b>	<b>30</b>	<b>–</b>	<b>–</b>	<b>–</b>	<b>30</b>	<b>–</b>	<b>–</b>	<b>–</b>	<b>–</b>
Personnel Carriers	989	11	489	260	19	45	27	82	56
Load Carriers	1,687	13	765	328	25	91	97	25	343
Motorcycles	702	40	345	172	20	32	29	28	35
Motorcycles with sidecars	621	1	369	46	57	46	29	3	70
Trailers	119	–	84	–	–	12	3	2	18

1) LMG includes those mounted on AFV.

2) Other tanks are command tanks, signal tanks, and MG-equipped tanks.

3) Armored Cars include command armored cars, signal armored cars, MG-equipped armored cars, and gun-equipped armored cars.

4) Including the Headquarters, Infantry Division (mot); the Motorcycle Messenger Platoon; and the Motorized Mapping Detachment.

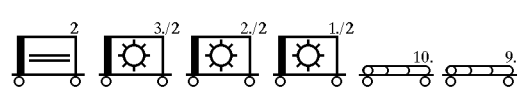
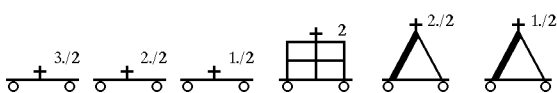
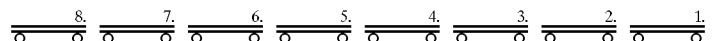
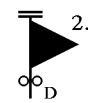
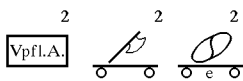
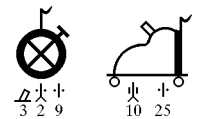
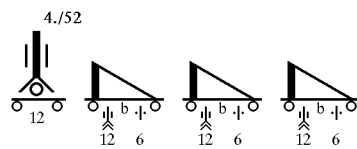
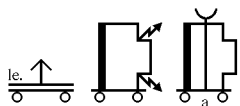
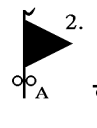
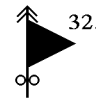
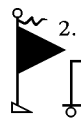
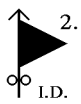
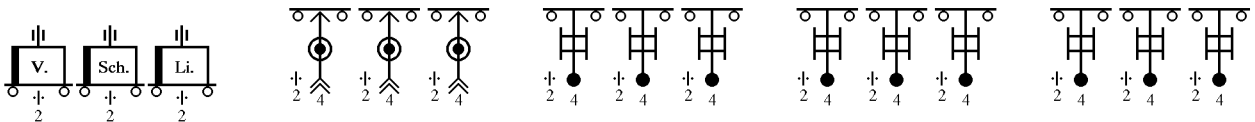
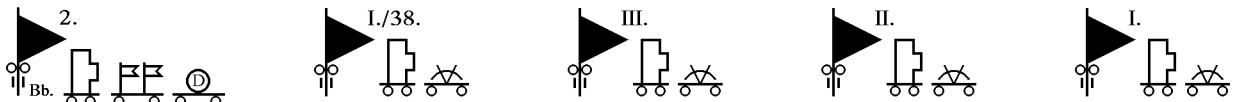
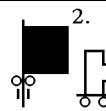
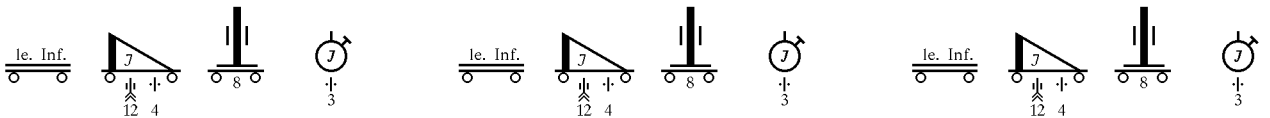
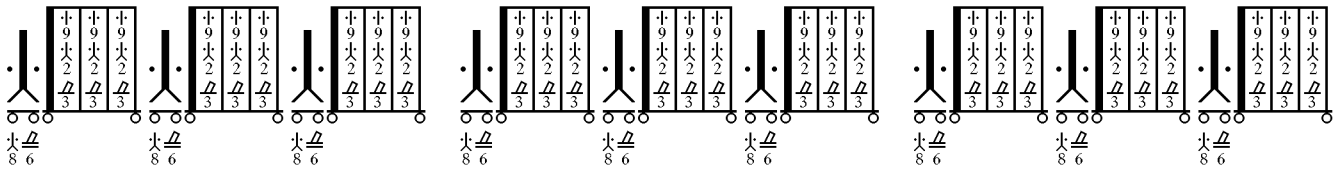
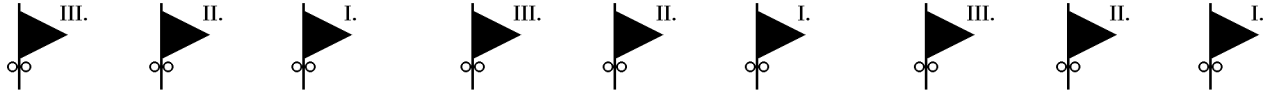
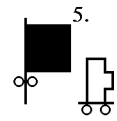
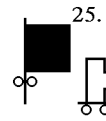
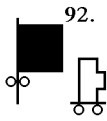
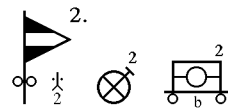

## 13. Infantry Division (motorized)

Activated 15.10.1935  
 Mobilized 18.08.1939  
 Home Garrison XI. Wehrkreis  
 Status on 1.09.1939

Assigned to XI. Armeekorps (mot), 10. Armee, Heeresgruppe Süd  
 Commanding General Generalleutnant (US equivalent is Major General □ □ )  
 Paul Otto

## Authorized Strength in accordance with the Mobilization Plan 1939/1940

	Division Total	Division Headquarters <sup>4</sup>	Infantry Regiments <sup>4</sup>	Artillery Regiment	Recon Battalion	Anti-Tank Battalion	Engineer Battalion	Signal Battalion	Support Services
Officers	492	17	246	106	15	22	22	4	50
Government Service Officials	133	14	33	14	3	3	2	3	61
Non-Commissioned Officers	2,456	26	1,467	372	58	132	91	74	236
Enlisted Men	13,364	106	7,572	2,345	310	551	716	333	1,431
<b>Total</b>	<b>16,445</b>	<b>163</b>	<b>9,318</b>	<b>2,837</b>	<b>386</b>	<b>708</b>	<b>831</b>	<b>424</b>	<b>1,778</b>
Pistols	4,142	49	2,538	479	162	259	142	28	485
Rifles	11,931	110	6,780	2,358	224	449	689	396	925
Sub-Machine Guns	31	–	–	–	31	–	–	–	–
Light Machine Guns <sup>1</sup>	374	–	264	30	35	18	27	–	–
Heavy Machine Guns	130	2	126	–	2	–	–	–	–
20mm AA Guns	12	–	–	–	–	12	–	–	–
37mm AT Guns	72	–	36	–	–	36	–	–	–
light (50mm) Mortars	84	–	81	–	3	–	–	–	–
heavy (81mm) Mortars	54	–	54	–	–	–	–	–	–
light (75mm) Infantry Guns	24	–	24	–	–	–	–	–	–
heavy (150mm) Infantry Guns	–	–	–	–	–	–	–	–	–
light (105mm) Field Howitzers	36	–	–	36	–	–	–	–	–
heavy (105mm) Guns	–	–	–	–	–	–	–	–	–
heavy (150mm) Field Howitzers	12	–	–	12	–	–	–	–	–
20mm AFV Guns	10	–	–	–	10	–	–	–	–
37mm AFV Guns	–	–	–	–	–	–	–	–	–
75mm AFV Guns	–	–	–	–	–	–	–	–	–
Gun Tanks	–	–	–	–	–	–	–	–	–
Other Tanks <sup>2</sup>	–	–	–	–	–	–	–	–	–
Armored Cars <sup>3</sup>	30	–	–	–	30	–	–	–	–
<b>Total AFV</b>	<b>30</b>	<b>–</b>	<b>–</b>	<b>–</b>	<b>30</b>	<b>–</b>	<b>–</b>	<b>–</b>	<b>–</b>
Personnel Carriers	989	11	489	260	19	45	27	82	56
Load Carriers	1,687	13	765	328	25	91	97	25	343
Motorcycles	702	40	345	172	20	32	29	28	35
Motorcycles with sidecars	621	1	369	46	57	46	29	3	70
Trailers	119	–	84	–	–	12	3	2	18

1) LMG includes those mounted on AFV.

2) Other tanks are command tanks, signal tanks, and MG-equipped tanks.

3) Armored Cars include command armored cars, signal armored cars, MG-equipped armored cars, and gun-equipped armored cars.

4) Including the Headquarters, Infantry Division (mot); the Motorcycle Messenger Platoon; and the Motorized Mapping Detachment.

1. Welle  
1.09.1939

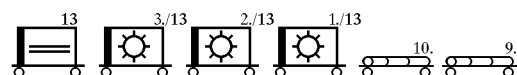
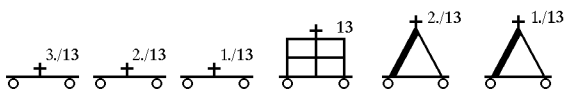
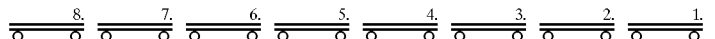
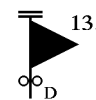
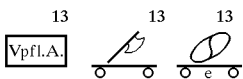
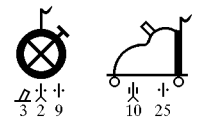
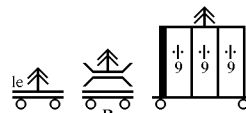
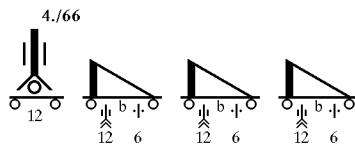
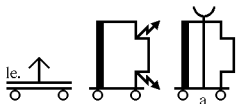
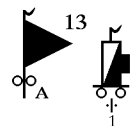
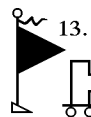
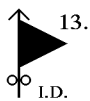
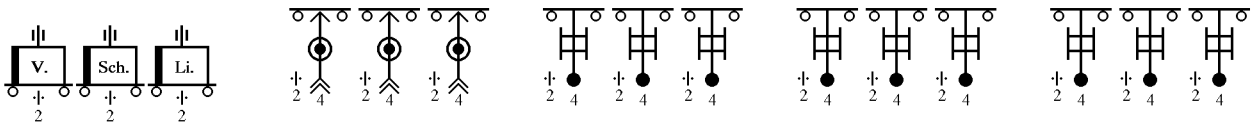
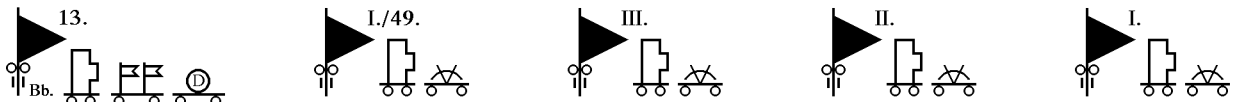
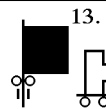
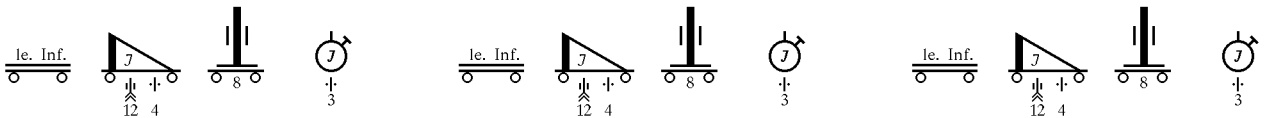
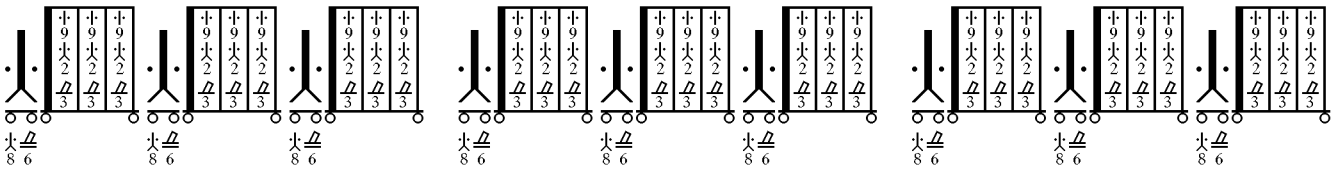
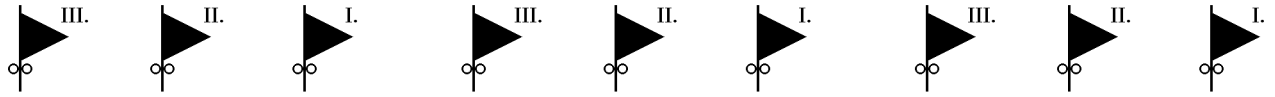
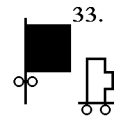
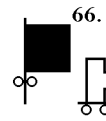
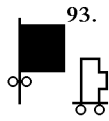
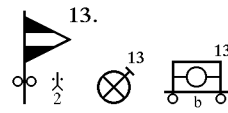

## 20. Infantry Division (motorized)

Activated 10.10.1936  
 Mobilized 01.08.1939  
 Home Garrison X. Wehrkreis  
 Status on 1.09.1939

Assigned to XIX. Armeekorps (mot), 4. Armee, Heeresgruppe Nord  
 Commanding General Generalleutnant (US equivalent is Major General □ □ )  
 Mauritz von Viktorin

## Authorized Strength in accordance with the Mobilization Plan 1939/1940

	Division Total	Division Headquarters <sup>4</sup>	Infantry Regiments	Artillery Regiment	Recon Battalion	Anti-Tank Battalion	Engineer Battalion	Signal Battalion	Support Services
Officers	492	17	246	106	15	22	22	4	50
Government Service Officials	133	14	33	14	3	3	2	3	61
Non-Commissioned Officers	2,456	26	1,467	372	58	132	91	74	236
Enlisted Men	13,364	106	7,572	2,345	310	551	716	333	1,431
<b>Total</b>	<b>16,445</b>	<b>163</b>	<b>9,318</b>	<b>2,837</b>	<b>386</b>	<b>708</b>	<b>831</b>	<b>424</b>	<b>1,778</b>
Pistols	4,142	49	2,538	479	162	259	142	28	485
Rifles	11,931	110	6,780	2,358	224	449	689	396	925
Sub-Machine Guns	31	–	–	–	31	–	–	–	–
Light Machine Guns <sup>1</sup>	374	–	264	30	35	18	27	–	–
Heavy Machine Guns	130	2	126	–	2	–	–	–	–
20mm AA Guns	12	–	–	–	–	12	–	–	–
37mm AT Guns	72	–	36	–	–	36	–	–	–
light (50mm) Mortars	84	–	81	–	3	–	–	–	–
heavy (81mm) Mortars	54	–	54	–	–	–	–	–	–
light (75mm) Infantry Guns	24	–	24	–	–	–	–	–	–
heavy (150mm) Infantry Guns	–	–	–	–	–	–	–	–	–
light (105mm) Field Howitzers	36	–	–	36	–	–	–	–	–
heavy (105mm) Guns	–	–	–	–	–	–	–	–	–
heavy (150mm) Field Howitzers	12	–	–	12	–	–	–	–	–
20mm AFV Guns	10	–	–	–	10	–	–	–	–
37mm AFV Guns	–	–	–	–	–	–	–	–	–
75mm AFV Guns	–	–	–	–	–	–	–	–	–
Gun Tanks	–	–	–	–	–	–	–	–	–
Other Tanks <sup>2</sup>	–	–	–	–	–	–	–	–	–
Armored Cars <sup>3</sup>	30	–	–	–	30	–	–	–	–
<b>Total AFV</b>	<b>30</b>	<b>–</b>	<b>–</b>	<b>–</b>	<b>30</b>	<b>–</b>	<b>–</b>	<b>–</b>	<b>–</b>
Personnel Carriers	989	11	489	260	19	45	27	82	56
Load Carriers	1,687	13	765	328	25	91	97	25	343
Motorcycles	702	40	345	172	20	32	29	28	35
Motorcycles with sidecars	621	1	369	46	57	46	29	3	70
Trailers	119	–	84	–	–	12	3	2	18

1) LMG includes those mounted on AFV.

2) Other tanks are command tanks, signal tanks, and MG-equipped tanks.

3) Armored Cars include command armored cars, signal armored cars, MG-equipped armored cars, and gun-equipped armored cars.

4) Including the Headquarters, Infantry Division (mot); the Motorcycle Messenger Platoon; and the Motorized Mapping Detachment.



1. Welle  
1.09.1939

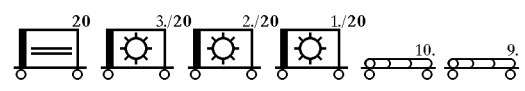
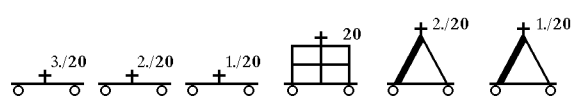
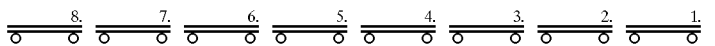
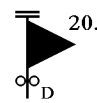
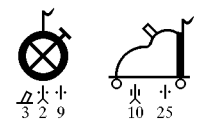
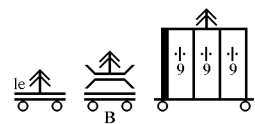
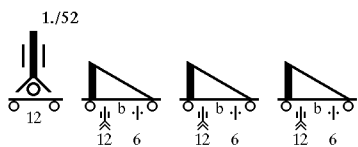
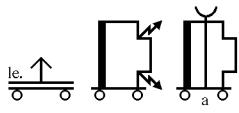
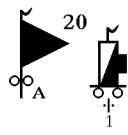
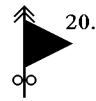
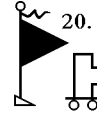
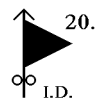
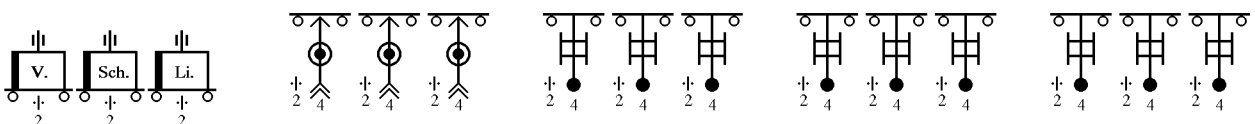
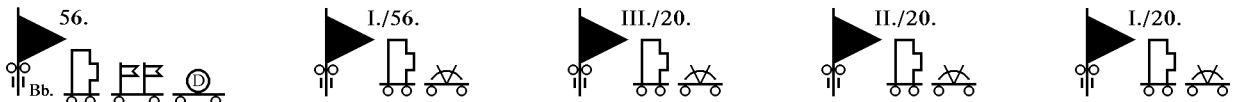
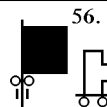
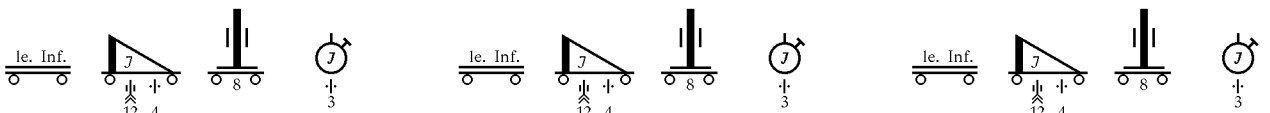
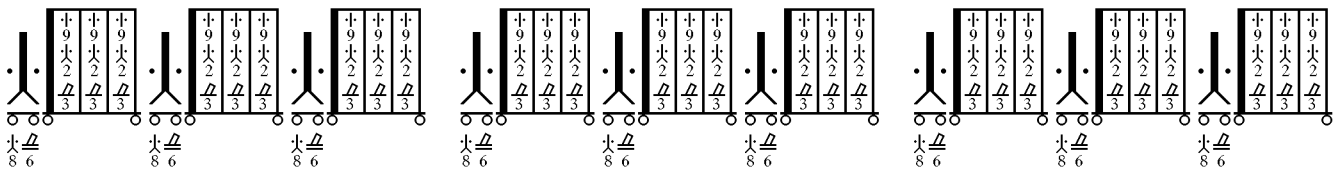
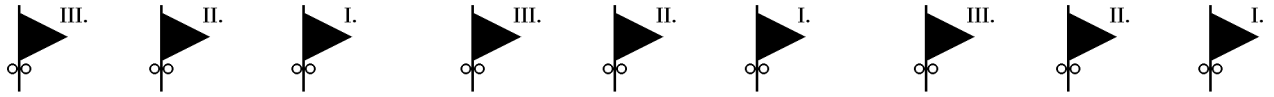
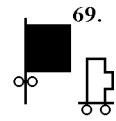
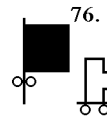
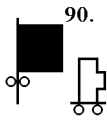
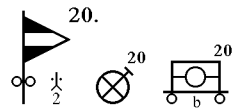

## 29. Infantry Division (motorized)

Activated 01.10.1936  
 Mobilized 24.08.1939  
 Home Garrison IX. Wehrkreis  
 Status on 1.09.1939

Assigned to XI. Armeekorps (mot), 10. Armee, Heeresgruppe Süd  
 Commanding General Generalmajor (US equivalent is Brigadier General □ )  
 Joachim Lemelsen

## Authorized Strength in accordance with the Mobilization Plan 1939/1940

	Division Total	Division Headquarters <sup>4</sup>	Infantry Regiments	Artillery Regiment	Recon Battalion	Anti-Tank Battalion	Engineer Battalion	Signal Battalion	Support Services
Officers	492	17	246	106	15	22	22	4	50
Government Service Officials	133	14	33	14	3	3	2	3	61
Non-Commissioned Officers	2,456	26	1,467	372	58	132	91	74	236
Enlisted Men	13,364	106	7,572	2,345	310	551	716	333	1,431
<b>Total</b>	<b>16,445</b>	<b>163</b>	<b>9,318</b>	<b>2,837</b>	<b>386</b>	<b>708</b>	<b>831</b>	<b>424</b>	<b>1,778</b>
Pistols	4,142	49	2,538	479	162	259	142	28	485
Rifles	11,931	110	6,780	2,358	224	449	689	396	925
Sub-Machine Guns	31	–	–	–	31	–	–	–	–
Light Machine Guns <sup>1</sup>	374	–	264	30	35	18	27	–	–
Heavy Machine Guns	130	2	126	–	2	–	–	–	–
20mm AA Guns	12	–	–	–	–	12	–	–	–
37mm AT Guns	72	–	36	–	–	36	–	–	–
light (50mm) Mortars	84	–	81	–	3	–	–	–	–
heavy (81mm) Mortars	54	–	54	–	–	–	–	–	–
light (75mm) Infantry Guns	24	–	24	–	–	–	–	–	–
heavy (150mm) Infantry Guns	–	–	–	–	–	–	–	–	–
light (105mm) Field Howitzers	36	–	–	36	–	–	–	–	–
heavy (105mm) Guns	–	–	–	–	–	–	–	–	–
heavy (150mm) Field Howitzers	12	–	–	12	–	–	–	–	–
20mm AFV Guns	10	–	–	–	10	–	–	–	–
37mm AFV Guns	–	–	–	–	–	–	–	–	–
75mm AFV Guns	–	–	–	–	–	–	–	–	–
Gun Tanks	–	–	–	–	–	–	–	–	–
Other Tanks <sup>2</sup>	–	–	–	–	–	–	–	–	–
Armored Cars <sup>3</sup>	30	–	–	–	30	–	–	–	–
<b>Total AFV</b>	<b>30</b>	<b>–</b>	<b>–</b>	<b>–</b>	<b>30</b>	<b>–</b>	<b>–</b>	<b>–</b>	<b>–</b>
Personnel Carriers	989	11	489	260	19	45	27	82	56
Load Carriers	1,687	13	765	328	25	91	97	25	343
Motorcycles	702	40	345	172	20	32	29	28	35
Motorcycles with sidecars	621	1	369	46	57	46	29	3	70
Trailers	119	–	84	–	–	12	3	2	18

1) LMG includes those mounted on AFV.

2) Other tanks are command tanks, signal tanks, and MG-equipped tanks.

3) Armored Cars include command armored cars, signal armored cars, MG-equipped armored cars, and gun-equipped armored cars.

4) Including the Headquarters, Infantry Division (mot); the Motorcycle Messenger Platoon; and the Motorized Mapping Detachment.

1. Welle  
1.09.1939

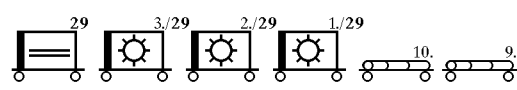
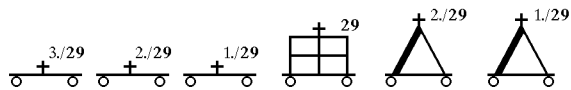
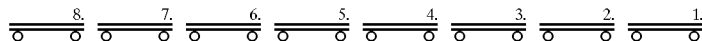
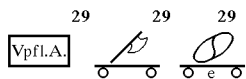
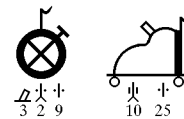
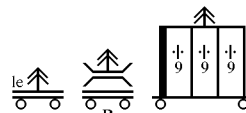
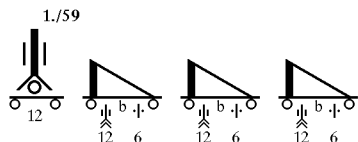
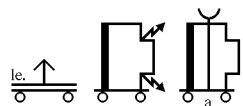
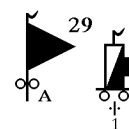
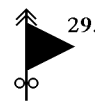
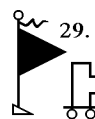
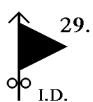
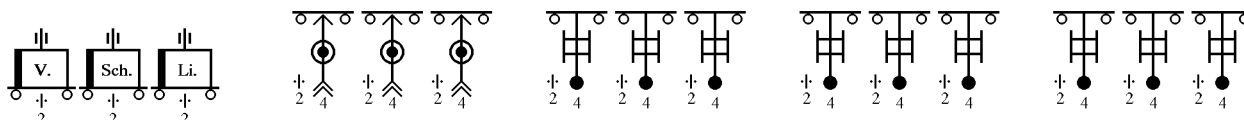
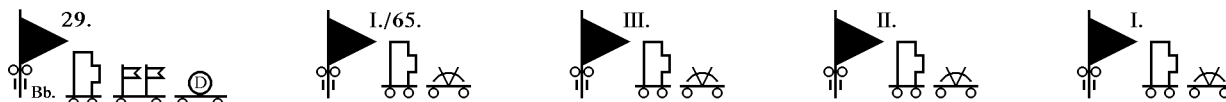
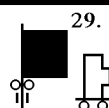
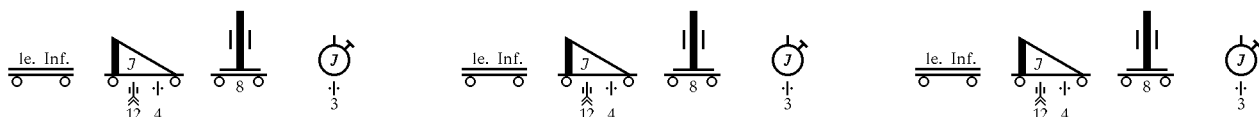
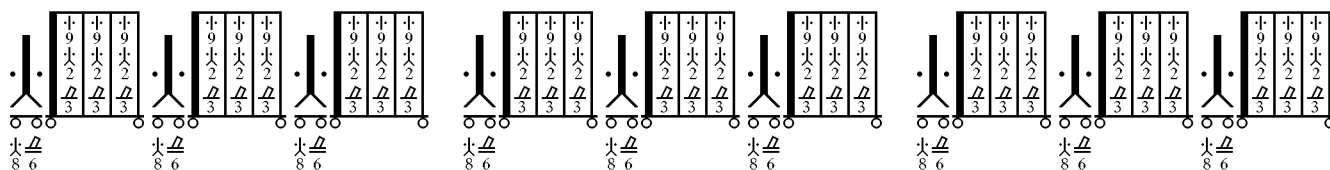
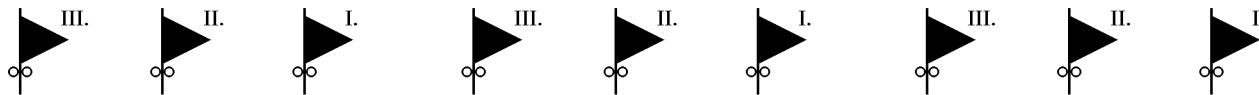
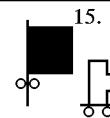
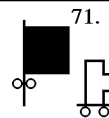
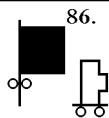
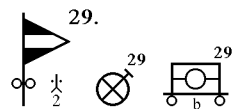

**STAB, INFANTERIE-DIVISION (motorisiert)**  
**Headquarters, Infantry Division (motorized)**

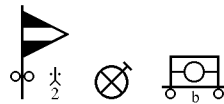

**KStN 23 \*)**  
1.10.1937

**Headquarters, Infantry Division (motorized)**

Div Hqs: (15 Off; 14 GSO; 13 NCO; 52 EM).

Div Gds: 1 Infantry Squad with 2 LMG.

Motor Pool: 2 mcl; 2 cars (light); 3 cars (medium); 3 cars (2/2); 1 car (21);  
 2 buses (light); 1 bus (medium – converted to office use);  
 6 trucks (light); 1 truck (medium); 2 ambulances (medium van).

**KStN 1067 \*)**

**Motorcycle Messenger Platoon**

1.10.1937

Plt Hqs: 3 mcl; 1 mcl w/sc; 1 car (11).

5 Sect: 7 mcl.

**KStN 2076**

**Motorized Mapping Detachment “b”**

1.10.1938

Det: 1 car (light); 1 bus (light – converted to office use).

**PANZER-ABWEHR-ABTEILUNG**  
**Motorized Anti-Tank Battalion**

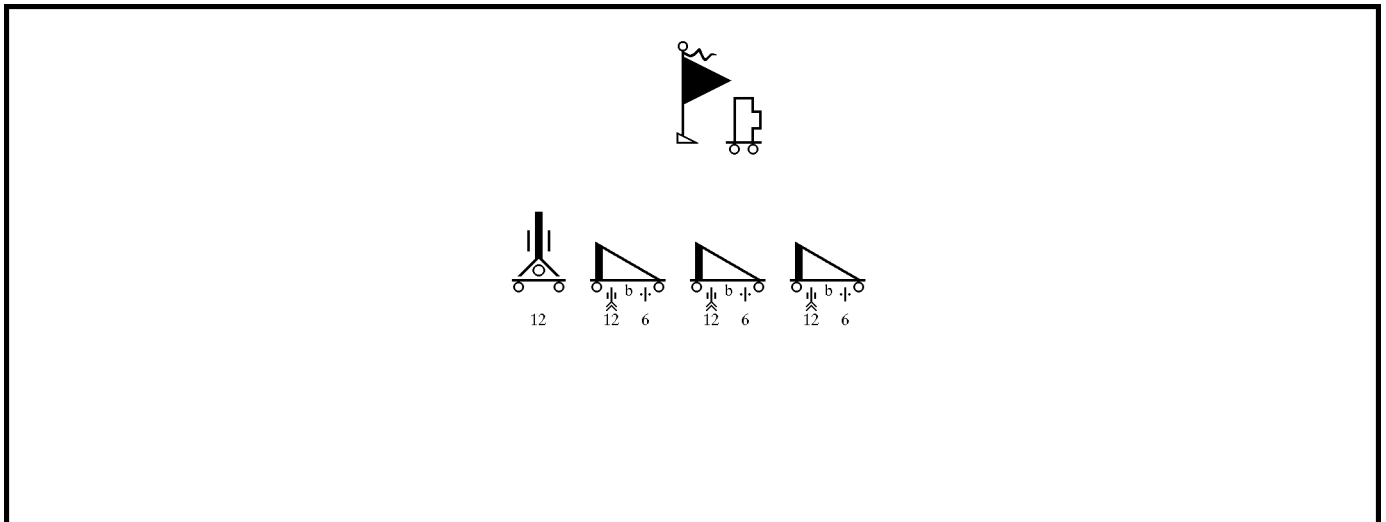

- KStN 1106 \*) Headquarters, Motorized Anti-Tank Battalion**  
1.10.1937  
Bn Hqs: 3 mcl; 2 mcl w/sc; 1 car (1); 1 car (12); 1 car (15).  
Bn Maint Det: 1 mcl w/sc; 1 car (light); 1 truck (light); 2 trucks (1.5-ton).  
Bn Trains: 3 mcl; 4 trucks (light).
- KStN 1192 \*) Motorized Signal Platoon, Motorized Anti-Tank Battalion**  
1.10.1937  
Plt Hqs: 2 mcl; 1 car (15/1).  
1 Lt Tele Sect *c*: 1 car (15/1).  
6 Pack Radio Sect *b*: 1 car (2/2).  
2 Lt Radio Sect *b*: 1 van (17).
- KStN 1143 \*) Motorized Anti-Tank Company "b"**  
1.10.1937  
Co Hqs: 4 mcl; 1 car (12).  
3 ATG Plt: Hqs Sect: 1 mcl; 1 mcl w/sc; 1 car (12).  
MG Sect: 2 cars (12); 2 LMG.  
Ammo Sect: 4 cars (12); 4 trailers (ammo).  
Gun Det: 4 cars (12); 4 ATG (37mm – towed).  
Co Trains: 1 mcl; 2 mcl w/sc; 1 car (12); 1 truck (light); 3 trucks (3-ton).
- KStN 191 \*) Motorized Light Anti-Aircraft Company**  
1.10.1937  
Co Hqs: 4 mcl; 1 car (1); 1 car (15).  
Signal Det: Hqs Sect: 1 car (15/2).  
1 Lt Tele Sect *c*: 1 car (15/1).  
4 Pack Radio Sect *d*: 1 car (2/2).  
1 Lt Radio Sect *c*: 1 van (17/1).  
3 AA Plt: Hqs Sect: 1 car (15/1).  
Ammo Sect: 2 halftracks (10).  
Gun Det: 4 halftracks (10); 4 AA Guns (20mm – towed).  
Co Trains: 2 mcl; 1 mcl w/sc; 1 car (15); 2 trucks (light); 2 trucks (2-ton); 2 trucks (3-ton).

**Order of Battle – Anti-Tank Battalions**

Div.	Battalion	Anti-Tank Companies	Anti-Aircraft Companies
2. Inf	2. Panzer-Abwehr-Abt.	3	4./52
13. Inf	13. Panzer-Abwehr-Abt.	3	4./66
20. Inf	20. Panzer-Abwehr-Abt.	3	1./52
29. Inf	29. Panzer-Abwehr-Abt.	3	1./59

**NOTES:**

The Light Anti-Aircraft Company was designated in German both as "Maschinengewehr Kompanie (s)", (Machine Gun Company (heavy)) or as "Fliegerabwehr-MG-Kompanie" (Anti-Aircraft MG Company). These light anti-aircraft units (with KStN numbering in the 100's), were raised by the Infantry Inspectorate.

**INFANTERIE-REGIMENT (motorisiert)**  
**Army Infantry Regiment (motorized)**

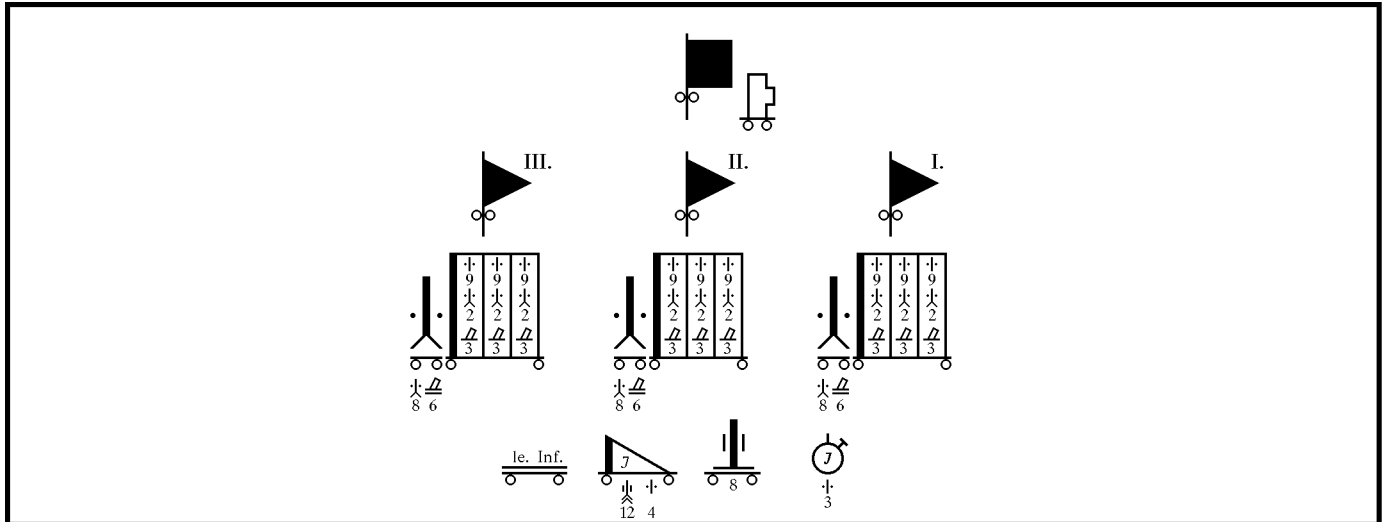

- KStN 103 \*) Headquarters, Infantry Regiment (motorized)**  
 1.10.1937 Rgt Hqs: 5 mcl; 2 mcl w/sc; 2 cars (12); 1 car (21).
- KStN 261 Signal Platoon, Infantry Regiment (motorized)**  
 1.10.1937 Plt Hqs: 1 mcl; 1 car (15); 1 truck (medium).  
 3 Lt Tele Sect *c*: 1 car (15/1).  
 2 Pack Radio Sect *d*: ride in Platoon Headquarters vehicles.  
 2 Pack Radio Sect *d*: 1 car (2/2)..
- KStN 146 \*) Infantry Motorcycle Platoon**  
 1.10.1937 Plt: 4 mcl; 1 mcl w/sc; 1 car (11); 1 truck (1.5-ton).  
 3 Inf Sqd: 4 mcl w/sc; 1 Infantry Squad with 1 LMG.
- KStN 202 Light Infantry Column (motorized)**  
 1.10.1937 Co Hqs: 2 mcl; 1 car (medium).  
 Ammo Plt: 1 mcl w/sc; 13 trucks (light).  
 Col Trains: 1 car (light); 3 trucks (light).
- KStN 173 Infantry-Gun Company (motorized)**  
 1.10.1937 Co Hqs: 3 mcl; 3 mcl w/sc; 1 car (12); 2 cars (15).  
 4 Lt IG Plt: Hqs Sect: 2 mcl; 1 mcl w/sc; 1 car (12); 1 car (15).  
 Gun Det: 6 cars (12); 4 Lt IG (75 – towed); 4 trailers (ammo).  
 Co Trains: 1 mcl; 1 mcl w/sc; 1 car (medium); 1 truck (light); 1 truck (1.5-ton); 1 truck (3-ton).
- KStN 184 Infantry Anti-Tank Company (motorized)**  
 5.10.1937 Co Hqs: 4 mcl; 2 mcl w/sc; 1 car (12).  
 4 ATG Plt: Hqs Sect: 3 mcl; 1 mcl w/sc; 1 car (12).  
 Gun Det: 7 cars (12); 3 ATG (37mm – towed); 3 trailers (ammo); 1 LMG.  
 Co Trains: 1 mcl w/sc; 1 car (light); 2 trucks (1.5-ton); 1 truck (3-ton).
- KStN 115 \*) Headquarters, Infantry Battalion (motorized)**  
 1.10.1937 Bn Hqs: 4 mcl; 2 mcl w/sc; 2 cars (11); 1 car (21).  
 Signal Det: Hqs Sect: 1 mcl w/sc; 1 car (15/2); 1 truck (1.5-ton)..  
 2 Lt Tele Sect *c*: 1 car (15/2).  
 4 Pack Radio Sect *d*: ride in Headquarters Section 1.5-ton truck.  
 Bn Trains: 3 mcl; 1 mcl w/sc; 4 trucks (light); 1 truck (3-ton).
- KStN 138 \*) Infantry Company (motorized)**  
 1.10.1937 Co Hqs: 3 mcl; 2 mcl w/sc; 1 car (11); 1 truck (3-ton).  
 3 Inf Plt: Hqs Sect: 1 mcl w/sc; 1 car (11).  
 3 Inf Sqd: 1 truck (3-ton); 1 Infantry Squad with 2 LMG.  
 1 Mortar Sect: 1 mortar (50mm); rides with one of the squads.  
 1 MG Det: Hqs Sect: 1 mcl; 1 mcl w/sc; 1 car (15).  
 1 HMG Sect: 1 truck (3-ton); 2 HMG.  
 Co Trains: 1 mcl; 1 mcl w/sc; 1 car (light); 4 trucks (light); 1 truck (3-ton).
- KStN 166 \*) Mixed Machine-Gun Company (motorized)**  
 1.10.1937 Co Hqs: 3 mcl; 2 mcl w/sc; 2 cars (11).  
 2 HMG Plt: Hqs Sect: 1 mcl w/sc; 1 car (11).  
 2 MG Sect: 1 truck (3-ton); 2 HMG.  
 1 Mortar Plt: Hqs Sect: 1 mcl; 1 car (11).  
 3 Mortar Sect: 1 mcl; 2 trucks (3-ton); 2 mortars (18mm).  
 Co Trains: 1 mcl; 1 mcl w/sc; 1 car (light); 6 trucks (light); 1 truck (3-ton).

**Note on German Motorized Infantry Designations in 1939:**

The motorized infantry battalions and regiments of the Infantry Division (motorized) was designated as "Infanterie-...(motorisiert); the companies as Schützen-Kompanie (motorisiert)".



**ARTILLERIE-REGIMENT (motorisiert)**  
**Motorized Artillery Regiment**

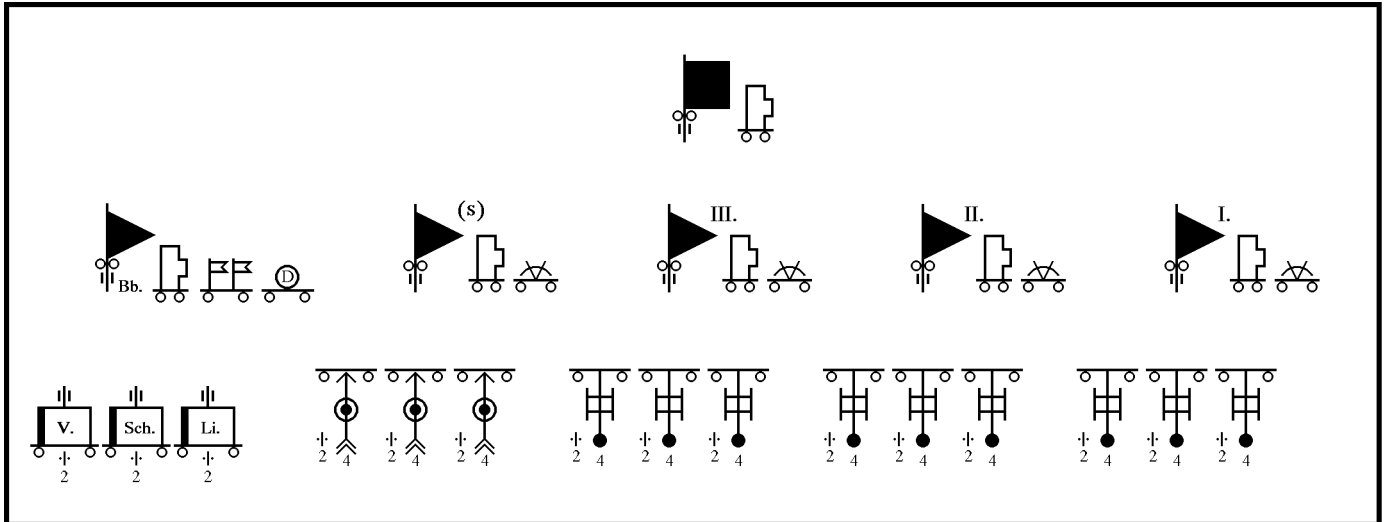

**KStN 411 \*)**  
1.10.1938

**Headquarters, Motorized Artillery Regiment**  
Rgt Hqs: 4 mcl; 1 car (1); 3 cars (15); 1 bus (medium).

**KStN 561 \*)**  
1.10.1937

**Signal Platoon, Motorized Artillery Regiment**  
Plt Hqs: 2 mcl; 1 car (15); 1 van (17/1).  
1 Hvy Tele Sect *b*: 1 car (2/1); 1 van (77).  
3 Lt Tele Sect *c*: 1 car (15/1).  
2 Lt Radio Sect *b*: 1 van (17).  
4 Pack Radio Sect *b*: 1 car (2/2).  
1 Lt Radio Sect *c*: 1 van (17/1).

**KStN 533 \*)**  
1.10.1936

**Headquarters, Motorized Artillery Observation Battalion**  
Bn Hqs: 1 mcl; 3 cars (1); 1 van (light).

**KStN 571 \*)**  
1.10.1938

**Motorized Signal Platoon, Motorized Artillery Observation Battalion**  
Hqs Sect: 1 car (15).  
2 Med Tele Sect *b*: 1 car (15); 1 van (76).  
4 Lt Radio Sect *b*: 1 van (17).

**KStN 538 \*)**  
1.10.1936

**Motorized Meteorological Platoon**  
Hqs: 1 mcl; 1 van (62).  
1 Wind Gauge Sect: 1 car (3).  
1 Temperature Measurement Sect: 1 van (62).  
3 Azimuth Sect: 1 van (62).  
1 Med Radio Sect *b*: 1 car (15); 1 van (76).

**KStN 527**  
1.12.1934

**Motorized Printing Detachment**  
Det: 1 mcl; 1 truck (3-ton); 1 van (62); 1 trailer (generator).

**KStN 534 \*)**  
1.10.1938

**Motorized Calibration Battery**  
Bty Hqs: 3 mcl; 1 car (16).  
3 Calibration Plt: Hqs Sect: 1 car (3); 1 car (16).  
3 Calibration Sect: 1 car (16).  
1 Evaluation Plt: Hqs Sect: 1 mcl w/sc; 1 car (16).  
1 Evaluation Sect: 1 van (62); 1 trailer (generator).  
1 Evaluation Sect: 1 van (62).  
1 Support Sect: 1 AA car (4 w/ dual MG); 1 van (64).  
Bty Trains: 1 mcl; 4 trucks (light); 1 truck (2-ton); 1 truck (medium).

**KStN 535**  
1.10.1938

**Motorized Sound Ranging Battery**  
Bty Hqs: 4 mcl; 1 car (16).  
1 Warning Plt: Hqs Sect: 1 car (3).  
2 Sect: 1 car (16).  
2 Sound Ranging Plt: Hqs Sect: 2 cars (3).  
2 Sect: 1 car (16); 1 van (63).  
1 Evaluation Plt: Hqs Sect: 1 mcl w/sc; 2 cars (light).  
2 Recording Sect: 1 van (62).  
1 Evaluation Sect: 1 van (62); 1 trailer (generator).  
1 Evaluation Sect: 1 van (62).  
1 Support Sect: 1 AA car (4 w/ dual MG); 1 van (64).  
Bty Trains: 1 mcl; 4 trucks (light); 1 truck (2-ton); 1 truck (medium).

**KStN 536 \*)**  
1.10.1938

**Motorized Flash Ranging Battery**  
Bty Hqs: 4 mcl; 1 car (16).  
3 Flash Ranging Plt: Hqs Sect: 2 cars (3).  
2 Sect: 1 car (16); 1 van (63).  
1 Evaluation Plt: Hqs Sect: 1 mcl w/sc; 2 cars (light).  
2 Recording Sect: 1 van (62).  
1 Evaluation Sect: 1 van (62); 1 trailer (generator).  
1 Evaluation Sect: 1 van (62).  
1 Support Sect: 1 AA car (4 w/ dual MG); 1 van (64).  
Bty Trains: 1 mcl; 4 trucks (light); 1 truck (2-ton); 1 truck (medium).



**ARTILLERIE-REGIMENT (motorisiert)**  
**Motorized Artillery Regiment**

- KStN 413**  
1.10.1937  
**Headquarters, Motorized Light Artillery Battalion**  
Bn Hqs: 3 mcl; 2 mcl w/sc; 1 car (1); 1 car (12); 1 car (15).  
Bn Maint Det: 1 mcl w/sc; 1 car (light); 1 truck (light); 2 trucks (1.5-ton).  
Bn Trains: 3 mcl; 4 trucks (light).
- KStN 556 \*)**  
1.10.1937  
**Motorized Signal Platoon, Motorized Light Artillery Battalion**  
Plt Hqs: 3 mcl; 1 mcl w/sc; 1 car (light); 1 car (15); 1 car (15/2).  
1 Med Tele Sect *b*: 1 car (15/1); 1 van (76).  
1 Hvy Tele Sect *b*: 1 car (2/1); 1 van (77).  
4 Lt Tele Sect *c*: 1 car /15/1).  
2 Pack Radio Sect *f*: 1 car (2/2).  
2 Pack Radio Sect *f*: ride with other sections of the platoon.
- KStN 529 \*)**  
15.02.1932  
**Motorized Calibration Detachment**  
Det: 2 mcl; 1 car (3); 1 truck (1.5-ton).
- KStN 434**  
1.10.1938  
**Motorized Light Field Howitzer Battery**  
Bty Hqs : 3 mcl; 1 car (11); 1 car (12).  
Signal Det: Hqs Sect: 1 car (2/2).  
1 Hvy Tele Sect *a*: 1 car (2/2); 1 van (23).  
1 Med Tele Sect *b*: 1 car (15/1); 1 van (76).  
1 Pack Radio Sect *f*: 1 car (2/2).  
2 Pack Radio Sect *f*: ride with other sections of the platoon.  
Gun Plt: 2 mcl; 1 car (1); 1 AA car (4 w/dual MG); 2 cars (12); 4 halftracks (6/1); 4 light Field Howitzers (105mm – towed).  
1 Ammo Det: 2 mcl; 1 mcl w/sc; 4 trucks (2-ton).  
1 Ammo Det: 1 mcl; 4 trucks (2-ton); 4 trailers (ammo).  
Bty Trains: 1 mcl; 1 mcl w/sc; 3 trucks (light); 1 truck (medium); 1 halftrack (6/1).
- KStN 406 \*)**  
1.10.1937  
**Headquarters, Motorized Heavy Artillery Battalion**  
Bn Hqs: 3 mcl; 2 mcl w/sc; 1 car (1); 2 cars (15).  
Bn Maint Det: 1 mcl w/sc; 1 car (light); 1 truck (light); 2 trucks (1.5-ton).  
Bn Trains: 2 mcl; 1 mcl w/sc; 6 trucks (light).
- KStN 555 \*)**  
1.10.1937  
**Motorized Signal Platoon, Motorized Heavy Artillery Battalion**  
Plt Hqs: 3 mcl; 1 mcl w/sc; 1 car (light); 1 car (15); 1 car (15/2).  
1 Hvy Tele Sect *a*: 1 car (2/2); 1 van (23).  
1 Med Tele Sect *b*: 1 car (15/1); 1 van (76).  
2 Lt Tele Sect *c*: 1 car (15/1).  
2 Pack Radio Sect *f*: 1 car (2/2).  
1 Lt Radio Sect *c*: 1 van (17/1).
- KStN 529 \*)**  
15.02.1932  
**Motorized Calibration Detachment**  
Det: 2 mcl; 1 car (3); 1 truck (1.5-ton).
- KStN 462 \*)**  
1.10.1938  
**Motorized Heavy Field Howitzer Battery**  
Bty Hqs : 3 mcl; 1 car (11); 1 car (12).  
Signal Det: Hqs Sect: 1 car (2/2).  
1 Hvy Tele Sect *a*: 1 car (2/2); 1 van (23).  
1 Med Tele Sect *b*: 1 car (15/1); 1 van (76).  
1 Pack Radio Sect *f*: 1 car (2/2).  
2 Pack Radio Sect *f*: ride with other sections of the platoon.  
Gun Plt: 2 mcl; 1 car (1); 1 AA car (4 w/dual MG); 2 cars (12); 4 halftracks (7); 4 heavy Field Howitzers (150mm – towed).  
1 Ammo Det: 2 mcl; 1 mcl w/sc; 4 trucks (2-ton).  
1 Ammo Det: 1 mcl; 4 trucks (2-ton); 4 trailers (ammo).  
Bty Trains: 1 mcl; 1 mcl w/sc; 3 trucks (light); 1 truck (medium); 1 halftrack (7).

**Order of Battle – Artillery Regiments (motorized)**

Div.	Artillery Regiment	Battalion	Batteries	Observation Battalion	Artillery Observation Battalion	
2. Inf	2. Artillerie-Regiment (mot)	I./2	1. le FH	2. le FH	3. le FH	2. Beobachtungs-Abteilung
		II./2	4. le FH	5. le FH	6. le FH	
		III./2	7. le FH	8. le FH	9. le FH	
		I./38	1. s FH	2. s FH	3. s SH	
13. Inf	13. Artillerie-Regiment (mot)	I./13	1. le FH	2. le FH	3. le FH	13. Beobachtungs-Abteilung
		II./13	4. le FH	5. le FH	6. le FH	
		III./13	7. le FH	8. le FH	9. le FH	
		I./49	1. s FH	2. s FH	3. s SH	
20. Inf	56. Artillerie-Regiment (mot)	I./20	1. le FH	2. le FH	3. le FH	56. Beobachtungs-Abteilung
		II./20	4. le FH	5. le FH	6. le FH	
		III./20	7. le FH	8. le FH	9. le FH	
		I./56	1. s FH	2. s FH	3. s SH	
29. Inf	29. Artillerie-Regiment (mot)	I./29	1. le FH	2. le FH	3. le FH	29. Beobachtungs-Abteilung
		II./29	4. le FH	5. le FH	6. le FH	
		III./29	7. le FH	8. le FH	9. le FH	
		I./65	1. s FH	2. s FH	3. s SH	

**AUFKLÄRUNGS-ABTEILUNG (motorisiert)**  
**Motorized Reconnaissance Battalion**

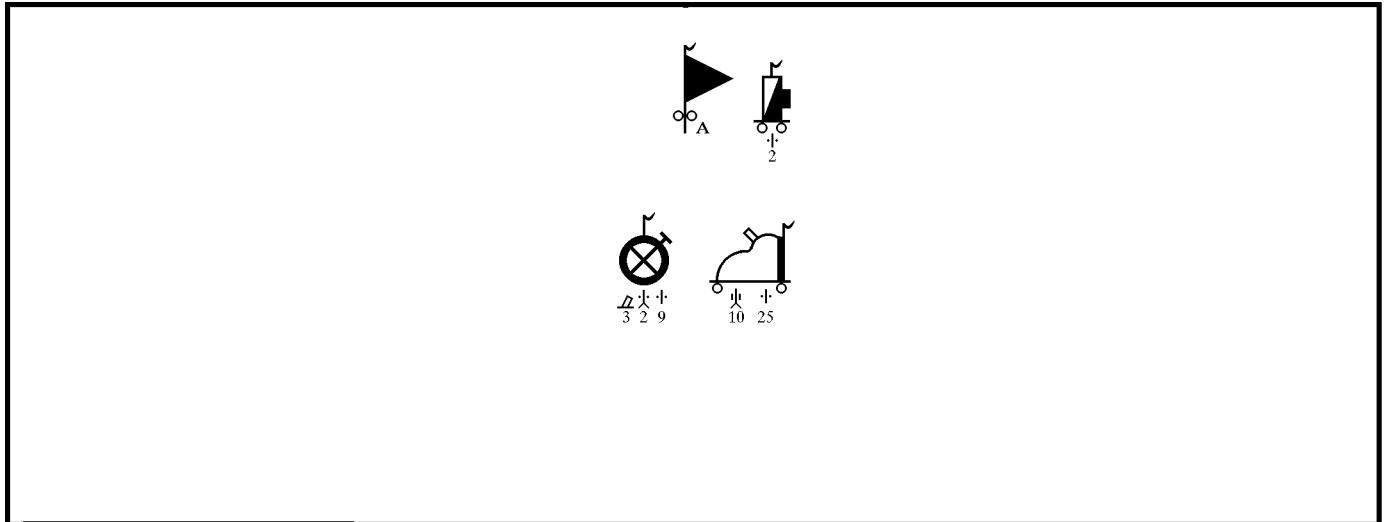

- KStN 1105a**  
1.10.1937 **Headquarters, Motorized Reconnaissance Battalion / Infantry Division (motorized)**  
Bn Hqs: 2 mcl; 3 mcl w/sc; 1 car (11); 1 car (15); 1 armored staff car (247).  
Bn Trains: 1 mcl w/sc; 1 car (1); 2 cars (15); 2 trucks (light); 3 trucks (1.5-ton); 1 ambulance (31).
- KStN 1191a**  
1.10.1938 **Motorized Signal Platoon / Motorized Reconnaissance Battalion / Infantry Division (motorized)**  
Plt Hqs: 1 mcl; 2 mcl w/sc; 1 car (15).  
2 Lt Tele Sect *c*: 1 car (15/2).  
2 Pack Radio Sect *d*: 1 car (2/2).  
1 Med Armd Radio Sect *b*: 1 car (15/2); 1 armored radio car (263).  
2 Lt Armd Radio Sect *d*: 1 armored radio car (261).  
1 Lt Armd Radio Sect *c*: 1 armored radio car (260).  
Personnel Replacement Det: 1 truck (1.5-ton).
- KStN 1162**  
1.10.1938 **Armored Car Company**  
Co Hqs: 6 mcl; 6 mcl w/sc; 1 car (11); 1 armored staff car (247).  
1 Signal Det: 4 armored radio cars (223).  
1 Med Armd Radio Sect *b*: 1 car (15/2); 1 armored radio car (263).  
1 Hvy Armored Car Plt: 3 armored cars (231); 3 armored radio cars (232).  
1 Lt Armored Car Plt: 6 armored cars (221).  
1 Lt Armored Car Plt: 4 armored cars (221); 4 armored cars (222).  
Co Trains: 2 mcl w/sc; 1 car (15); 1 truck (light); 7 trucks (2-ton).
- KStN 1111**  
1.10.1937 **Motorcycle Reconnaissance Company**  
Co Hqs: 3 mcl; 1 mcl w/sc; 1 car (11); 1 car (15).  
3 Mcl Plt: Hqs Sect: 2 mcl; 1 car (11); 1 car (18).  
3 Mcl Sqd: 3 mcl w/sc; 1 Reconnaissance Squad with 1 LMG.  
1 Mortar Sect: 2 mcl w/sc; 1 mortar (50mm).  
MG Det: 10 mcl w/sc; 2 HMG.  
Co Trains: 2 mcl w/sc; 1 car (15); 1 truck (light); 5 trucks (1.5-ton).

**Order of Battle – Reconnaissance Battalions**

Div.	Battalion	Armored Car Company	Motorcycle Company
2. Inf	2. Aufklärungs-Abt.	1	1
13. Inf	13. Aufklärungs-Abt.	1	1
20. Inf	20. Aufklärungs-Abt.	1	1
29. Inf	29. Aufklärungs-Abt.	1	1

**Note on German Motorized Reconnaissance Designations in 1939:**

All company echelon units of reconnaissance battalions were designated as “Schwadron”, (British Army designation would be Squadron; the US Army designation would be Troop), not “Kompanie” (Company).

The prefix “Panzer-” for reconnaissance battalions was not used until 1.04.1940.

**PIONIER-BATAILLON (motorisiert)**  
**Motorized Combat Engineer Battalion**

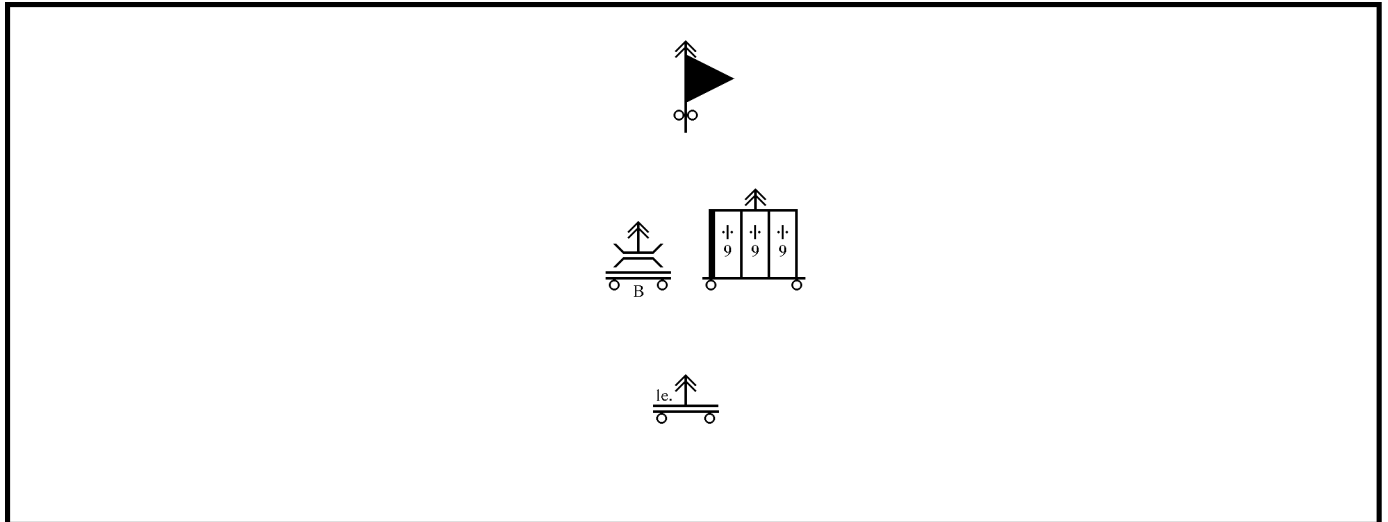
**KStN 703**

1.10.1937

**Headquarters, Motorized Combat Engineer Battalion**

Bn Hqs: 3 mcl; 2 mcl w/sc; 1 car (11); 2 cars (15).  
 Signal Det: Hqs Sect: 1 mcl w/sc.  
                   2 Pack Radio Sect *b*: 1 car (2).  
                   2 Pack Radio Sect *b*: ride together in 1 truck (2-ton).  
 Bn Hqs Trains: 2 mcl; 2 trucks (light).

**KStN 712**

1.10.1937

**Motorized Combat Engineer Company**

Co Hqs: 1 mcl; 4 mcl w/sc; 1 car (15).  
 2 Pack Radio Sect *b*: 1 car (15).  
 3 Engr Plt: Hqs Sect: 1 mcl; 1 mcl w/sc; 1 car (15); 1 truck (3-ton).  
                   3 Engr Sect: 1 truck (3-ton); 1 Combat Engineer Section with 1 LMG.  
 Co Trains: 1 mcl; 2 trucks (light); 4 trucks (medium).

**KStN 733**

1.10.1937

**Motorized Type B Bridge Column**

Col Hqs: 3 mcl; 1 car (1).  
 2 Bridge Plt: Hqs Sect: 1 mcl; 1 car (light).  
                   Trestle Sect: 4 halftracks (7); 4 trailers (4-wheel w/ trestles)  
                   Pontoon Sect: 8 trucks (3-ton); 8 trailers (4-wheel w/ 3 pontoons each).  
                   Boat Sect: 1 truck (3-ton); 1 trailer (4-wheel w/ motor boat).  
 1 Support Plt: 2 mcl w/sc; 1 truck (light); 1 truck (medium); 3 trucks (3-ton); 1 trailer (2-wheel w/ winch); 2 trailers (4-wheel w/ ramps).  
 Col Trains: 1 truck (light).

**KStN 741**

1.10.1937

**Motorized Light Engineer Column**

Col Hqs: 1 mcl; 1 mcl w/sc; 1 car (light).  
 1 Plt: 1 mcl; 1 mcl w/sc; 6 trucks (medium); 2 trailers (2-wheel w/ air compressor).  
 1 Plt: 1 mcl; 1 mcl w/sc; 7 trucks (medium); 1 ambulance (31).  
 Col Trains: 1 mcl; 1 truck (light).

**Order of Battle – Motorized Combat Engineer Battalions**

Div.	Battalion	Combat Engineer Companies	Bridge Columns
2. Inf	32. Pionier-Batallion (mot)	3	B
13. Inf	4. Pionier-Batallion (mot)	3	B
20. Inf	20. Pionier-Batallion (mot)	3	B
29. Inf	29. Pionier-Batallion (mot)	3	B

**NACHRICHTEN-ABTEILUNG (motorisiert)**  
**Motorized Signal Battalion**

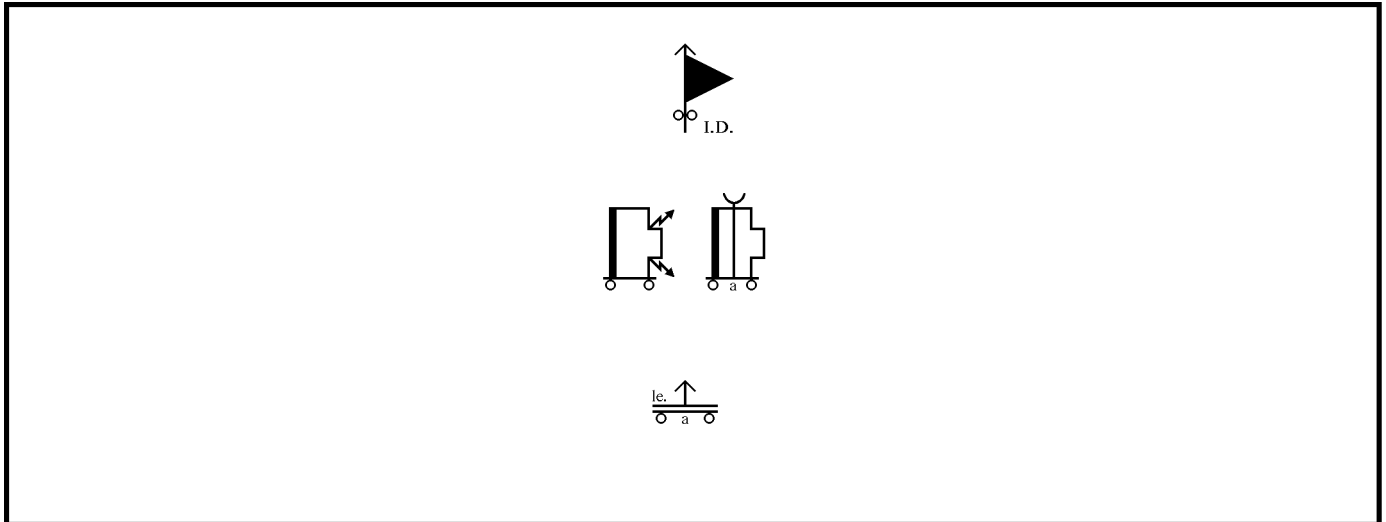

- KStN 807**  
1.10.1937 **Headquarters, Motorized Divisional Signal Battalion**  
Bn Hqs: 2 mcl; 3 cars (15); 2 trucks (1.5-ton).
- KStN 871 \*)**  
1.10.1937 **Motorized Light Signal Column "a" / Infantry Division (motorized)**  
Col: 1 mcl w/sc; 1 car (light); 1 truck (light); 4 trucks (medium); 2 vans (42); 1 trailer (generator).
- KStN 832 \*)**  
1.10.1938 **Motorized Telephone Company "a" / Infantry Division (motorized)**  
Co Hqs: 1 mcl; 1 mcl w/sc; 1 car (15); 1 truck (1.5-ton).  
1st Plt: Hqs Sect: 2 mcl; 1 car (15).  
3 Tele Ops Sect *a*: 1 car (15); 1 van (17).  
4 Lt Tele Sect *b*: 1 car (15).  
2nd Plt: Hqs Sect: 2 mcl; 1 car (15).  
4 Hvy Tele Sect *a*: 1 car (2); 1 van (23).  
3rd Plt: Hqs Sect: 2 mcl; 1 car (15).  
4 Hvy Tele Sect *a*: 1 car (2); 1 van (23).  
4th Plt: Hqs Sect: 2 mcl; 1 car (15).  
4 Hvy Tele Sect *a*: 1 car (2); 1 van (23).  
Co Trains: 1 car (15); 3 trucks (light); 2 trucks (medium).
- KStN 858 \*)**  
1.10.1938 **Motorized Radio Company / Infantry Division (motorized)**  
Co Hqs: 1 mcl; 1 mcl w/sc; 1 car (15); 1 truck (1.5-ton).  
1st Plt: Hqs Sect: 2 mcl; 1 car (15).  
5 Med Radio Sect *a*: 1 car (15); 1 van (17).  
2 Lt Radio Sect *c*: 1 van (17/1).  
2 Pack Radio Sect *b*: 1 car (2/2).  
2nd Plt: Hqs Sect: 2 mcl; 1 car (15).  
10 Lt Radio Sect *d*:  
3rd Plt: Hqs Sect: 2 mcl; 1 car (15).  
4 Pack Radio Sect *d*: 1 car (2/2).  
2 Pack Radio Sect *b*: 1 car (2/2).  
1 Radio Interception Sect: 1 van (76).  
1 Radio Listening Sect: 1 van (76).  
1 Code Sect: 2 cars (15).  
Co Trains: 1 car (15); 3 trucks (light); 3 trucks (medium); 1 van (42); 1 trailer (generator).

**Order of Battle – Motorized Signal Battalions**

Div.	Battalion	Telephone Company	Radio Company
2. Inf	2. Nachrichten-Abteilung (mot)	1	1
13. Inf	13. Nachrichten-Abteilung (mot)	1	1
20. Inf	20. Nachrichten-Abteilung (mot)	1	1
29. Inf	29. Nachrichten-Abteilung (mot)	1	1

**DIVISIONS VERSORGUNGSDIENSTE**  
**Divisional Support Services**

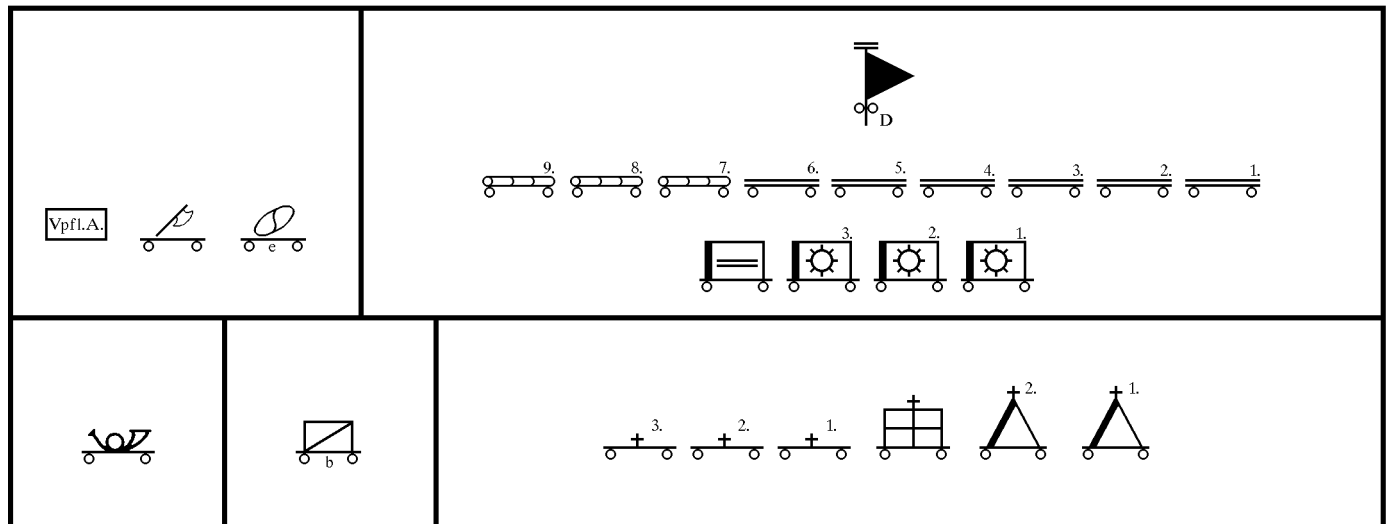

- KStN 1208 \*) Headquarters, Motorized Divisional Supply Battalion**  
1.03.1939  
Bn Hqs: 1 mcl; 4 mcl; 1 car (medium); 1 bus (light/11 seats).  
Bn Trains: 1 truck (light).
- KStN 1225 Motorized Transport Column (30 tons)**  
1.10.1937  
Col Hqs: 1 mcl; 1 mcl w/sc; 2 cars (light).  
2 Sect: 5 trucks (medium).  
1 Sect: 1 mcl w/sc; 1 truck (light).
- KStN 1226 Motorized Fuel Transport Column (25 m<sup>3</sup>)**  
1.10.1937  
Col Hqs: 1 mcl; 1 mcl w/sc; 1 car (light).  
2 Sect: 5 trucks (medium).  
1 Sect: 1 mcl w/sc; 1 truck (light).
- KStN 1052 Motorized Motor Maintenance Company**  
1.10.1937  
Co Hqs: 1 mcl; 1 car (light).  
2 Maint Plt: 1 mcl w/sc; 1 car (light); 1 truck (light); 1 truck (heavy); 1 bus (medium/31 seats); 1 van (79); 1 halftrack (7); 1 trailer (cargo); 1 trailer (tool).  
1 Armorer Plt: 2 mcl w/sc; 1 truck (2-ton); 4 trucks (medium).  
Co Trains: 1 mcl w/sc; 1 car (light); 2 trucks (light).
- KStN 1255 Motorized Supply Company**  
1.10.1937  
Co Hqs: 2 mcl w/sc; 1 car (light); 1 truck (light).  
3 Supply Plt: 1 mcl w/sc; 3 trucks (medium).  
1 Technical Plt: 1 mcl w/sc; 3 trucks (medium).  
Co Trains: 1 mcl; 1 truck (light).
- KStN 2086 \*) Motorized Divisional Rations Administration Detachment**  
1.02.1937  
Det: 1 mcl; 4 trucks (medium).
- KStN 1282 \*) Motorized Butchery Platoon**  
1.10.1938  
Co Hqs: 1 mcl; 1 mcl w/sc; 1 car (light).  
2 Plt: 3 trucks (medium); 1 trailer (generator).  
Co Trains: 1 mcl w/sc; 1 car (light); 3 trucks (light).
- KStN 1277 \*) Motorized Bakery Company "e"**  
1.10.1937  
Co Hqs: 1 mcl; 1 car (light).  
2 Plt: 3 trucks (heavy); 1 truck (heavy – water); 1 bus (medium/33 seats); 1 trailer (dough mixer); 2 trailers (oven).  
Co Trains: 1 mcl w/sc; 1 car (light); 3 trucks (light).
- KStN 1313 Motorized Medical Company**  
1.10.1937  
Co Hqs: 1 mcl; 1 mcl w/sc; 2 cars (15); 1 truck (light); 1 bus.  
2 Lt Radio Sect a: ride in company headquarters light truck.  
2 Medical Plt: 1 mcl w/sc; 1 car (11); 5 truck (medium); 1 van (medium); 5 ambulances (31).
- KStN 1342 Motorized Field Hospital**  
1.10.1937  
Co Hqs: 2 mcl w/sc; 1 car (medium); 1 truck (light); 1 bus (medium).  
2 Hospital Plt: 1 car (light); 3 trucks (light); 1 van (medium); 1 bus (light); 1 ambulance (31).
- KStN 1365 \*) Motorized Ambulance Platoon**  
1.10.1937  
Plt Hqs: 1 car (light); 2 trucks (light).  
3 Sect: 5 ambulances (31).
- KStN 2033b \*) Motorized Military Police Detachment "b"**  
1.10.1938  
Det: 12 mcl; 4 mcl w/sc; 14 cars (light); 1 truck (light).
- KStN 2251 \*) Motorized Field Post Detachment**  
1.04.1935  
Det: 3 cars (light); 1 truck (medium).

**SS-UNITS AUTHORIZED STRENGTHS**  
in accordance with the Mobilization Plan 1939/1940

	SS- Standarte	LSSAH- Standarte	Artillery Standarte	Antiaircraft Battalion	Recon Battalion	Engineer Battalion	Signal Battalion
Officers	88	89	?	?	?	23	15
Government Service Officials	11	11	?	?	?	2	3
Non-Commissioned Officers	542	547	?	?	?	112	95
Enlisted Men	2704	2755	?	?	?	722	399
<b>Total</b>	<b>3345</b>	<b>3402</b>	<b>?</b>	<b>?</b>	<b>?</b>	<b>859</b>	<b>452</b>
Pistols	950	962	?	?	?	137	56
Rifles	2405	2405	?	?	?	545	396
Sub-Machine Guns	8	8	?	?	?	–	–
Light Machine Guns <sup>1</sup>	102	105	?	?	?	18	–
Heavy Machine Guns	44	44	?	?	?	–	–
20mm AA Guns	4	4	?	?	?	–	–
37mm AT Guns	12	12	?	?	?	–	–
light (50mm) Mortars	30	30	?	?	?	–	–
heavy (81mm) Mortars	18	18	?	?	?	–	–
light (75mm) Infantry Guns	8	8	?	?	?	–	–
heavy (150mm) Infantry Guns	–	–	?	?	?	–	–
light (105mm) Field Howitzers	–	–	?	?	?	–	–
heavy (105mm) Guns	–	–	?	?	?	–	–
heavy (150mm) Field Howitzers	–	–	?	?	?	–	–
20mm AFV Guns	–	–	?	?	?	–	–
37mm AFV Guns	–	–	?	?	?	–	–
75mm AFV Guns	–	–	?	?	?	–	–
Gun Tanks	–	–	?	?	?	–	–
Other Tanks <sup>2</sup>	–	–	?	?	?	–	–
Armored Cars <sup>3</sup>	8	8	?	?	?	–	–
<b>Total AFV</b>	<b>8</b>	<b>8</b>	<b>?</b>	<b>?</b>	<b>?</b>	<b>–</b>	<b>–</b>
Personnel Carriers	175	176	?	?	?	24	82
Load Carriers	264	270	?	?	?	85	25
Motorcycles	148	150	?	?	?	26	28
Motorcycles with sidecars	163	165	?	?	?	26	3
Trailers	28	28	?	?	?	3	2

1) LMG includes those mounted on AFV.

2) Other tanks are command tanks, signal tanks, and MG-equipped tanks.

3) Armored Cars include command armored cars, signal armored cars, MG-equipped armored cars, and gun-equipped armored cars.

**NOTES:**

The Waffen-SS was not part of the Wehrmacht (German Armed Forces), but formed a separate, broadly speaking, fourth service. The designation "Waffen-SS" has been used for SS field combat units here, as opposed to strictly political or paramilitary SS units. Waffen-SS units have been very well documented. On 1.09.1939, there were no Waffen-SS divisions. There were enough SS-Verfügungs-Truppen to make up one Infantry Division (motorized), but no divisional headquarters had been raised as yet.

Waffen-SS units were thrown into the hottest part of the fight – by the Army, because they were not of their own; by the Nazi party, because they were there to prove the superiority of the Nazi doctrine and spirit which had created them.

The infantry regiments of the SS were organized with extra units. As a divisional base did not exist at the time of their conception, they were originally organized to be able to operate independently, (and so did operate during the 1939 Polish Campaign), and included reconnaissance and engineer elements.

The SS designated its units differently than the Army:

<b>Heer</b>	<b>SS &amp; Waffen-SS</b>	<b>Army</b>
Regiment	SS-Standarte	Regiment
Battalion	SS-Sturmabteilung	Battalion
Abteilung	SS-Sturm	Battalion
Kompanie	SS-Sturm	Company
Batterie	SS-Sturm	Battery
Schwadron	SS-Sturm	Squadron
Zug	SS-Schar	Platoon

The official SS system of nomenclature was difficult to apply in military situations, and did not really endure for the Waffen-SS. Frequently, and as the war continued, standard German Army terminology tended to be used more and more often. The *Standarte* designation by itself, as indicated above, was used for the infantry regiments. For all other units, the type of unit was indicated before the size designation, e.g.

<b>Army</b>	<b>Waffen-SS</b>
Infantry Regiment	SS-Standarte
Infantry Battalion	SS-Sturmabteilung
Infantry Company	SS-Sturm
Artillery Regiment	SS-Artillerie-Standarte
Signal Battalion	SS-Nachrichten-Sturmabteilung

**SS-STANDARTE (motorisiert)  
SS Infantry Regiment (motorized)**

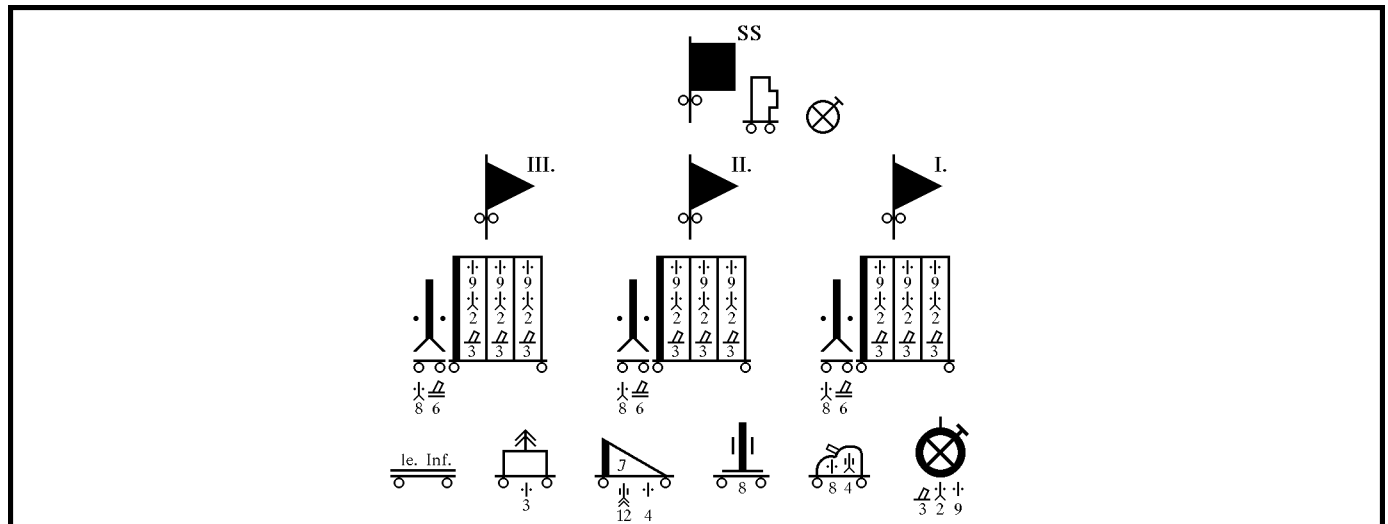

- KStN 103 \*)**  
1.10.1937 **Headquarters, Infantry Regiment (motorized)**  
Rgt Hqs: 5 mcl; 2 mcl w/sc; 2 cars (12); 1 car (21).
- KStN 261**  
1.10.1937 **Signal Platoon, Infantry Regiment (motorized)**  
Plt Hqs: 1 mcl; 1 car (15); 1 truck (medium).  
3 Lt Tele Sect c: 1 car (15/1).  
2 Pack Radio Sect d: ride in Platoon Headquarters vehicles.  
2 Pack Radio Sect d: 1 car (2/2)..
- KStN 1067 \*)**  
1.10.1937 **Motorcycle Messenger Platoon**  
Plt Hqs: 3 mcl; 1 mcl w/sc; 1 car (11).  
5 Sect: 7 mcl.
- KStN 146 \*)**  
1.10.1937 **Infantry Motorcycle Platoon**  
Plt: 4 mcl; 1 mcl w/sc; 1 car (11); 1 truck (1.5-ton).  
3 Inf Sqd: 4 mcl w/sc; 1 Infantry Squad with 1 LMG.
- KStN 202**  
1.10.1937 **Light Infantry Column (motorized)**  
Co Hqs: 2 mcl; 1 car (medium).  
Ammo Plt: 1 mcl w/sc; 13 trucks (light).  
Col Trains: 1 car (light); 3 trucks (light).
- KStN 173**  
1.10.1937 **Infantry-Gun Company (motorized)**  
Co Hqs: 3 mcl; 3 mcl w/sc; 1 car (12); 2 cars (15).  
4 Lt IG Plt: Hqs Sect: 2 mcl; 1 mcl w/sc; 1 car (12); 1 car (15).  
Gun Det: 6 cars (12); 4 lt IG (75 – towed); 4 trailers (ammo).  
Co Trains: 1 mcl; 1 mcl w/sc; 1 car (medium); 1 truck (light); 1 truck (1.5-ton); 1 truck (3-ton).
- KStN 184**  
5.10.1937 **Infantry Anti-Tank Company (motorized)**  
Co Hqs: 4 mcl; 2 mcl w/sc; 1 car (12).  
4 ATG Plt: Hqs Sect: 3 mcl; 1 mcl w/sc; 1 car (12).  
Gun Det: 7 cars (12); 3 ATG (37mm – towed); 3 trailers (ammo); 1 LMG.  
Co Trains: 1 mcl w/sc; 1 car (light); 2 trucks (1.5-ton); 1 truck (3-ton).
- KStN 1111**  
1.10.1937 **Motorcycle Infantry Company**  
Co Hqs: 3 mcl; 1 mcl w/sc; 1 car (11); 1 car (15).  
3 Mcl Plt: Hqs Sect: 2 mcl; 1 car (11); 1 car (18).  
3 Mcl Sqd: 3 mcl w/sc; 1 Infantry Squad with 1 LMG.  
1 Mortar Sect: 2 mcl w/sc; 1 mortar (50mm).  
MG Det: 10 mcl w/sc; 2 HMG.  
Co Trains: 2 mcl w/sc; 1 car (15); 1 truck (light); 5 trucks (1.5-ton).
- KStN 1136**  
1.03.1939 **SS-Armored Car Platoon**  
Lt Sect: 4 armored cars (221).  
Hvy Sect: 2 armored cars (231); 2 armored radio cars (232)
- KStN 1124**  
1.10.1937 **Motorized Engineer Platoon**  
Hqs Sect: 2 mcl; 1 mcl w/sc; 1 car (15).  
Engr Det: 1 mcl w/sc; 2 cars (15); 3 truck (2-ton); 3 LMG.
- KStN 115 \*)**  
1.10.1937 **Headquarters, Infantry Battalion (motorized)**  
Bn Hqs: 4 mcl; 2 mcl w/sc; 2 cars (11); 1 car (21).  
Signal Det: Hqs Sect: 1 mcl w/sc; 1 car (15/2); 1 truck (1.5-ton)..  
2 Lt Tele Sect c: 1 car (15/2).  
4 Pack Radio Sect d: ride in Headquarters Section 1.5-ton truck.  
Bn Trains: 3 mcl; 1 mcl w/sc; 4 trucks (light); 1 truck (3-ton).
- KStN 138 \*)**  
1.10.1937 **Infantry Company (motorized)**  
Co Hqs: 3 mcl; 2 mcl w/sc; 1 car (11); 1 truck (3-ton).  
3 Inf Plt: Hqs Sect: 1 mcl w/sc; 1 car (11).  
3 Inf Sqd: 1 truck (3-ton); 1 Infantry Squad with 2 LMG.  
1 Mortar Sect: 1 mortar (50mm); rides with one of the squads.  
1 MG Det: Hqs Sect: 1 mcl; 1 mcl w/sc; 1 car (15).  
1 HMG Sect: 1 truck (3-ton); 2 HMG.  
Co Trains: 1 mcl; 1 mcl w/sc; 1 car (light); 4 trucks (light); 1 truck (3-ton).
- KStN 166 \*)**  
1.10.1937 **Mixed Machine-Gun Company (motorized)**  
Co Hqs: 3 mcl; 2 mcl w/sc; 2 cars (11).  
2 HMG Plt: Hqs Sect: 1 mcl w/sc; 1 car (11).  
2 MG Sect: 1 truck (3-ton); 2 HMG.  
1 Mortar Plt: Hqs Sect: 1 mcl; 1 car (11).  
3 Mortar Sect: 1 mcl; 2 trucks (3-ton); 2 mortars (18mm).  
Co Trains: 1 mcl; 1 mcl w/sc; 1 car (light); 6 trucks (light); 1 truck (3-ton).

The *Leibstandarte SS-Adolf Hitler* had a slightly modified organization, but the difference was in personnel, and is not obvious from the above diagram or text. The *IV./LSSAH* was a watch unit stationed in Berlin, and is not detailed here.

On 1.09.1939, the *SS-Standarte* were located as follows:  
*SS-Standarte Deutschland* Panzer-Verband Kempf  
*SS-Standarte Germania* Prague  
*SS-Standarte Der Führer* Prague  
*Leibstandarte SS-Adolf Hitler* XIII. Army Corps

**SS-ARTILLERIE-STANDARTE (motorisiert)**  
**SS Motorized Artillery Regiment**

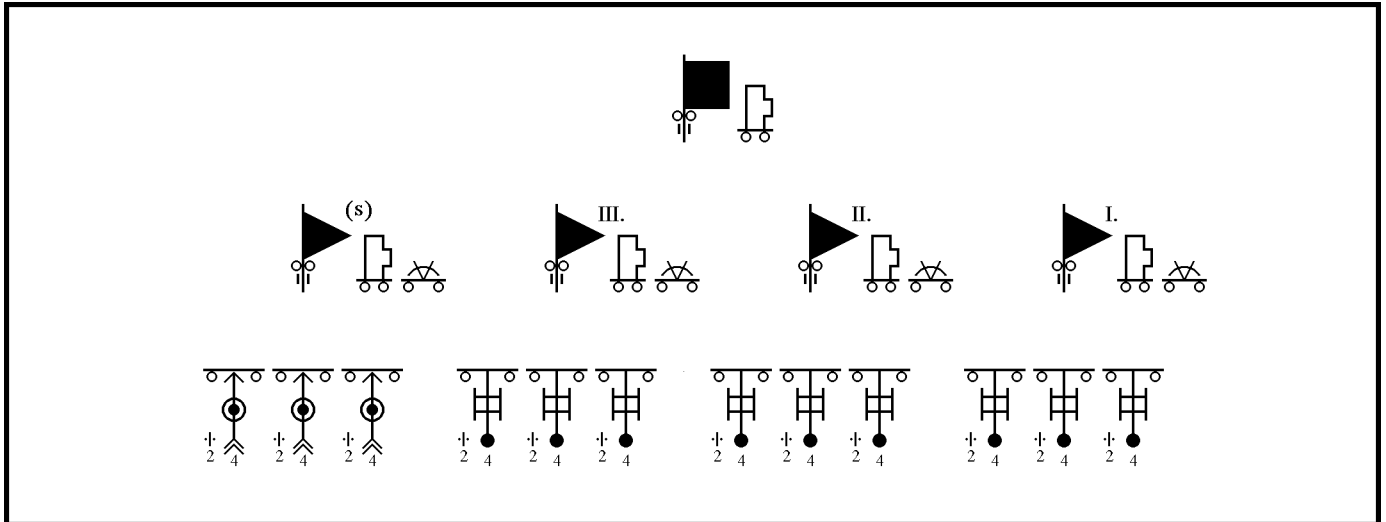

- KStN 411 \*)**  
1.10.1938  
**Headquarters, Motorized Artillery Regiment**  
Rgt Hqs: 4 mcl; 1 car (1); 3 cars (15); 1 bus (medium).
- KStN 561 \*)**  
1.10.1937  
**Signal Platoon, Motorized Artillery Regiment**  
Plt Hqs: 2 mcl; 1 car (15); 1 van (17/1).  
1 Hvy Tele Sect *b*: 1 car (2/1); 1 van (77).  
3 Lt Tele Sect *c*: 1 car (15/1).  
2 Lt Radio Sect *b*: 1 van (17).  
4 Pack Radio Sect *b*: 1 car (2/2).  
1 Lt Radio Sect *c*: 1 van (17/1).
- KStN 413**  
1.10.1937  
**Headquarters, Motorized Light Artillery Battalion**  
Bn Hqs: 3 mcl; 2 mcl w/sc; 1 car (1); 1 car (12); 1 car (15).  
Bn Maint Det: 1 mcl w/sc; 1 car (light); 1 truck (light); 2 trucks (1.5-ton).  
Bn Trains: 3 mcl; 4 trucks (light).
- KStN 556 \*)**  
1.10.1937  
**Motorized Signal Platoon, Motorized Light Artillery Battalion**  
Plt Hqs: 3 mcl; 1 mcl w/sc; 1 car (light); 1 car (15); 1 car (15/2).  
1 Med Tele Sect *b*: 1 car (15/1); 1 van (76).  
1 Hvy Tele Sect *b*: 1 car (2/1); 1 van (77).  
4 Lt Tele Sect *c*: 1 car (15/1).  
2 Pack Radio Sect *f*: 1 car (2/2).  
2 Pack Radio Sect *f*: ride with other sections of the platoon.
- KStN 529 \*)**  
15.02.1932  
**Motorized Calibration Detachment**  
Det: 2 mcl; 1 car (3); 1 truck (1.5-ton).
- KStN 434**  
1.10.1938  
**Motorized Light Field Howitzer Battery**  
Bty Hqs: 3 mcl; 1 car (11); 1 car (12).  
Signal Det: Hqs Sect: 1 car (2/2).  
1 Hvy Tele Sect *a*: 1 car (2/2); 1 van (23).  
1 Med Tele Sect *b*: 1 car (15/1); 1 van (76).  
1 Pack Radio Sect *f*: 1 car (2/2).  
2 Pack Radio Sect *f*: ride with other sections of the platoon.  
Gun Plt: 2 mcl; 1 car (1); 1 AA car (4 w/dual MG); 2 cars (12); 4 halftracks (6/1); 4 light Field Howitzers (105mm – towed).  
1 Ammo Det: 2 mcl; 1 mcl w/sc; 4 trucks (2-ton).  
1 Ammo Det: 1 mcl; 4 trucks (2-ton); 4 trailers (ammo).  
Bty Trains: 1 mcl; 1 mcl w/sc; 3 trucks (light); 1 truck (medium); 1 halftrack (6/1).
- KStN 406 \*)**  
1.10.1937  
**Headquarters, Motorized Heavy Artillery Battalion**  
Bn Hqs: 3 mcl; 2 mcl w/sc; 1 car (1); 2 cars (15).  
Bn Maint Det: 1 mcl w/sc; 1 car (light); 1 truck (light); 2 trucks (1.5-ton).  
Bn Trains: 2 mcl; 1 mcl w/sc; 6 trucks (light).
- KStN 555 \*)**  
1.10.1937  
**Motorized Signal Platoon, Motorized Heavy Artillery Battalion**  
Plt Hqs: 3 mcl; 1 mcl w/sc; 1 car (light); 1 car (15); 1 car (15/2).  
1 Hvy Tele Sect *a*: 1 car (2/2); 1 van (23).  
1 Med Tele Sect *b*: 1 car (15/1); 1 van (76).  
2 Lt Tele Sect *c*: 1 car (15/1).  
2 Pack Radio Sect *f*: 1 car (2/2).  
1 Lt Radio Sect *c*: 1 van (17/1).
- KStN 529 \*)**  
15.02.1932  
**Motorized Calibration Detachment**  
Det: 2 mcl; 1 car (3); 1 truck (1.5-ton).
- KStN 462 \*)**  
1.10.1938  
**Motorized Heavy Field Howitzer Battery**  
Bty Hqs: 3 mcl; 1 car (11); 1 car (12).  
Signal Det: Hqs Sect: 1 car (2/2).  
1 Hvy Tele Sect *a*: 1 car (2/2); 1 van (23).  
1 Med Tele Sect *b*: 1 car (15/1); 1 van (76).  
1 Pack Radio Sect *f*: 1 car (2/2).  
2 Pack Radio Sect *f*: ride with other sections of the platoon.  
Gun Plt: 2 mcl; 1 car (1); 1 AA car (4 w/dual MG); 2 cars (12); 4 halftracks (7); 4 heavy Field Howitzers (150mm – towed).  
1 Ammo Det: 2 mcl; 1 mcl w/sc; 4 trucks (2-ton).  
1 Ammo Det: 1 mcl; 4 trucks (2-ton); 4 trailers (ammo).  
Bty Trains: 1 mcl; 1 mcl w/sc; 3 trucks (light); 1 truck (medium); 1 halftrack (7).

**NOTES:**

On 1.09.1939, the *SS-Artillerie-Standarte (mot)* was attached to the Panzer-Verband Kempf.



**SS-FLIEGERABWEHR-MG-BATAILLON**  
**SS Antiaircraft MG Battalion**

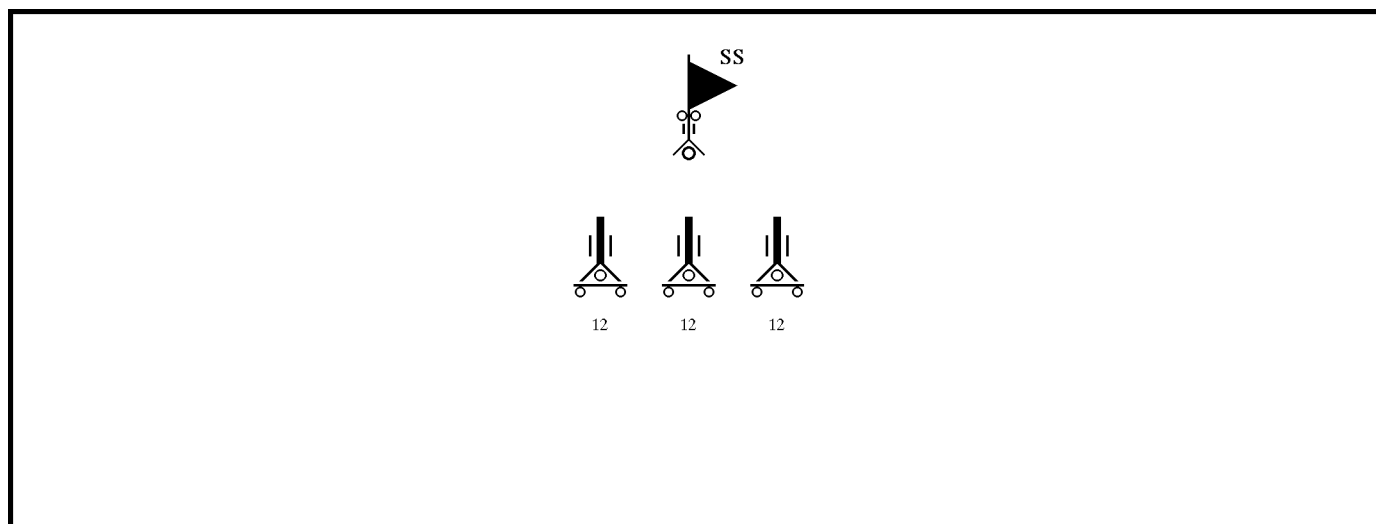

**KStN ? \*)**  
?

**Headquarters, Motorized Light Antiaircraft Battalion**

Bn Hqs: 7 mcl; 1 car (light); 3 cars (15).  
 Bn Maint Det: 1 mcl w/sc; 1 car (light); 1 car (2/40); 3 trucks (3-ton).  
 Bn Trains: 5 mcl; 2 cars (light); 2 trucks (light); 2 trucks (2-ton); 1 truck (3-ton); 1 ambulance (31).  
 Signal Plt: Hqs Sect: 1 car (2).  
 6 Pack Radio Sect *b*: 1 car (2).

**KStN 191 \*)**  
1.10.1937

**Motorized Light Antiaircraft Company**

Co Hqs: 4 mcl; 1 car (1); 1 car (15).  
 Signal Det: Hqs Sect: 1 car (15/2).  
 1 Lt Tele Sect *c*: 1 car (15/1).  
 4 Pack Radio Sect *d*: 1 car (2/2).  
 1 Lt Radio Sect *c*: 1 van (17/1).  
 3 AA Plt: Hqs Sect: 1 car (15/1).  
 Ammo Sect: 2 halftracks (10).  
 Gun Det: 4 halftracks (10); 4 AA Guns (20mm – towed).  
 Co Trains: 2 mcl; 1 mcl w/sc; 1 car (15); 2 trucks (light); 2 trucks (2-ton); 2 trucks (3-ton).

**NOTES:**

The Light Antiaircraft Company was designated in 1939 by the Germans both as “Maschinengewehr Kompanie (s)”, (Machine Gun Company (heavy)) or as “Fliegerabwehr-MG-Kompanie” (Antiaircraft MG Company). These light antiaircraft units were raised under an Infantry Inspectorate KStN.

The SS had an antiaircraft battalion consisting a headquarters and three light antiaircraft companies. No KStN of a headquarters for a light AAMG battalion prior to 1.12.1939 has been found. So the KStN 123 of 1.02.1941 has been used instead.

Only the 2./SS Antiaircraft Company saw action in the 1939 Polish Campaign, while attached to the SS-*Standarte Deutschland*, under Panzer-Verband Kempf. The rest of the battalion remained in its garrisons.

**SS-AUFKLÄRUNGS-STURMBANN (motorisiert)**  
**SS Motorized Reconnaissance Battalion**

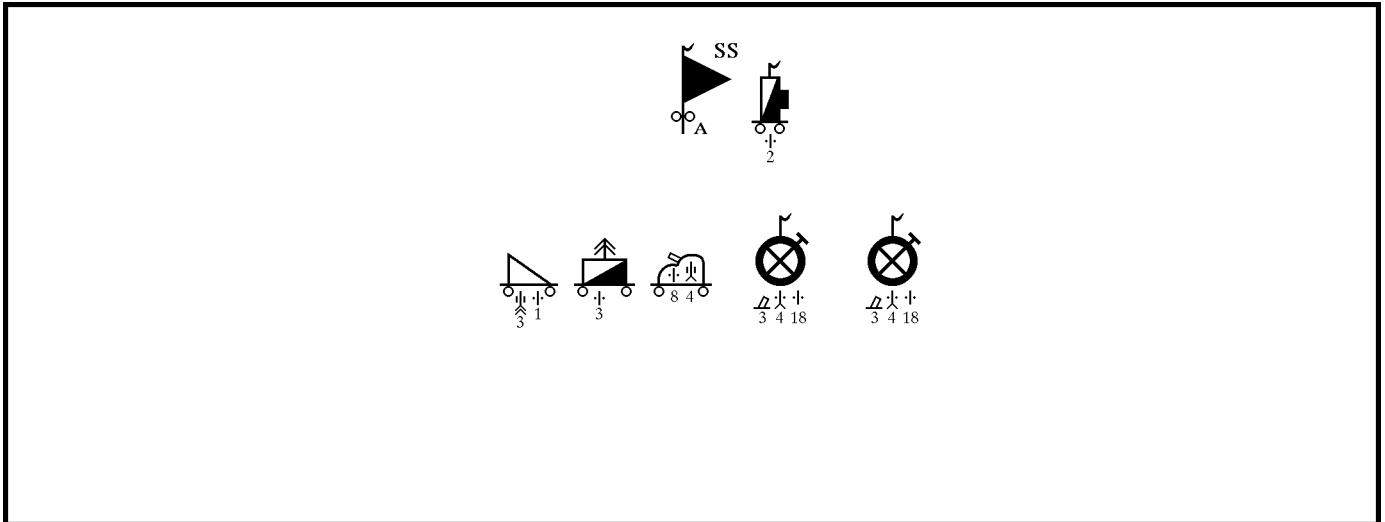

- KStN 1105a** **Headquarters, Motorized Reconnaissance Battalion / Infantry Division (motorized)**  
 1.10.1937  
 Bn Hqs: 2 mcl; 3 mcl w/sc; 1 car (11); 1 car (15); 1 armored staff car (247).  
 Bn Trains: 1 mcl w/sc; 1 car (1); 2 cars (15); 2 trucks (light); 3 trucks (1.5-ton); 1 ambulance (31).
- KStN 1191a** **Motorized Signal Platoon / Motorized Reconnaissance Battalion / Infantry Division (motorized)**  
 1.10.1938  
 Plt Hqs: 1 mcl; 2 mcl w/sc; 1 car (15).  
 2 Lt Tele Sect c: 1 car (15/2).  
 2 Pack Radio Sect d: 1 car (2/2).  
 1 Med Armd Radio Sect b: 1 car (15/2); 1 armored radio car (263).  
 2 Lt Armd Radio Sect d: 1 armored radio car (261).  
 1 Lt Armd Radio Sect c: 1 armored radio car (260).  
 Personnel Replacement Det: 1 truck (1.5-ton).
- KStN 1111a** **Motorcycle Reconnaissance Company**  
 1.10.1937  
 Co Hqs: 3 mcl; 1 mcl w/sc; 1 car (15); 1 car (18).  
 3 Mcl Plt: Hqs Sect: 2 mcl; 1 car (11); 1 car (18).  
 3 Mcl Sqd: 4 mcl w/sc; 1 Infantry Squad with 2 LMG.  
 1 Mortar Sect: 2 mcl w/sc 1 mortar (50mm).  
 1 MG Plt: Hqs Sect: 1 mcl; 2 mcl w/sc; 1 car (15); 1 car (18).  
 1 Lt Tele Sect c: 1 car (15/2).  
 MG Det: 14 mcl w/sc; 4 HMG.  
 Co Trains: 2 mcl w/sc; 1 car (15); 1 truck (light); 5 trucks (1.5-ton).
- KStN 1136** **SS-Armored Car Platoon**  
 1.03.1939  
 Lt Sect: 4 armored cars (221).  
 Hvy Sect: 2 armored cars (231); 2 armored radio cars (232)
- KStN 1122** **Motorized Anti-Tank Platoon**  
 1.10.1937  
 Hqs Sect: 1 mcl; 1 mcl w/sc; 1 truck (69).  
 Gun Det: 4 trucks (69); 3 ATG (37mm – towed); 1 LMG.
- KStN 1124** **Motorized Engineer Platoon**  
 1.10.1937  
 Hqs Sect: 2 mcl; 1 mcl w/sc; 1 car (15).  
 Engr Det: 1 mcl w/sc; 2 cars (15); 3 truck (2-ton); 3 LMG.

**NOTES:**

On 1.09.1939, the *SS-Aufklärungs-Sturm* was attached to Panzer-Verband Kempf.

**SS-PIONIER-STURMBANN (MOTORISIERT)**  
**SS Motorized Combat Engineer Battalion**

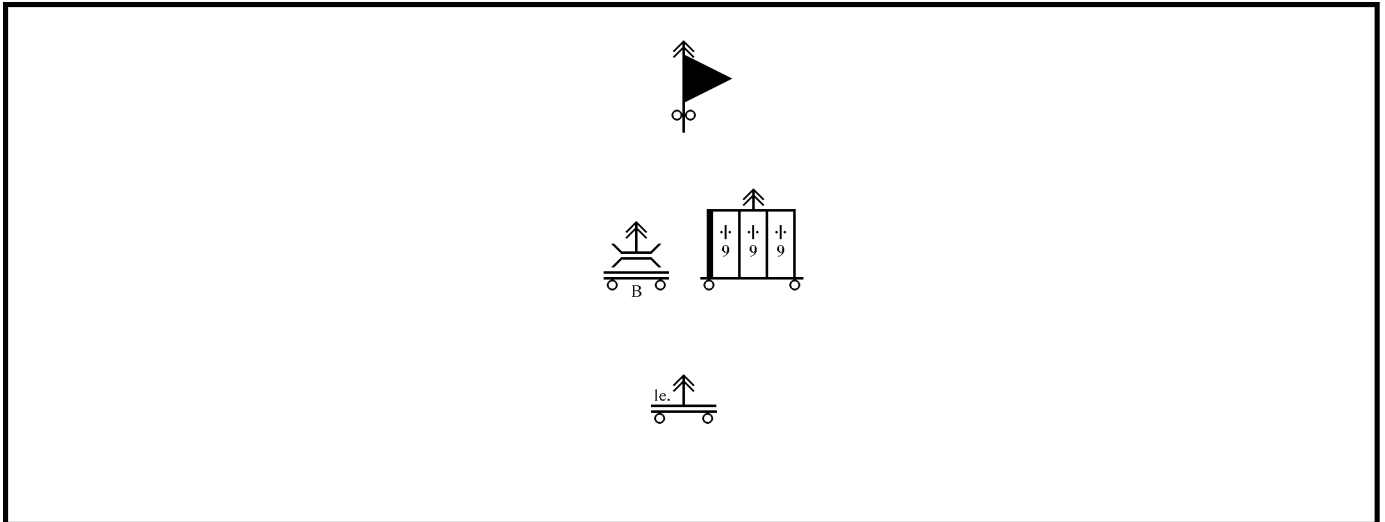

**KStN 703**  
1.10.1937

**Headquarters, Motorized Combat Engineer Battalion**

Bn Hqs: 3 mcl; 2 mcl w/sc; 1 car (11); 2 cars (15).  
 Signal Det: Hqs Sect: 1 mcl w/sc.  
 2 Pack Radio Sect *b*: 1 car (2).  
 2 Pack Radio Sect *b*: ride together in 1 truck (2-ton).  
 Bn Hqs Trains: 2 mcl; 2 trucks (light).

**KStN 712**  
1.10.1937

**Motorized Combat Engineer Company**

Co Hqs: 1 mcl; 4 mcl w/sc; 1 car (15).  
 2 Pack Radio Sect *b*: 1 car (15).  
 3 Engr Plt: Hqs Sect: 1 mcl; 1 mcl w/sc; 1 car (15); 1 truck (3-ton).  
 3 Engr Sect: 1 truck (3-ton); 1 Combat Engineer Section with 1 LMG.  
 Co Trains: 1 mcl; 2 trucks (light); 4 trucks (medium).

**KStN 733**  
1.10.1937

**Motorized Type B Bridge Column**

Col Hqs: 3 mcl; 1 car (1).  
 2 Bridge Plt: Hqs Sect: 1 mcl; 1 car (light).  
 Trestle Sect: 4 halftracks (7); 4 trailers (4-wheel w/ trestles)  
 Pontoon Sect: 8 trucks (3-ton); 8 trailers (4-wheel w/ 3 pontoons each).  
 Boat Sect: 1 truck (3-ton); 1 trailer (4-wheel w/ motor boat).  
 1 Support Plt: 2 mcl w/sc; 1 truck (light); 1 truck (medium); 3 trucks (3-ton); 1 trailer (2-wheel w/ winch); 2 trailers (4-wheel w/ ramps).  
 Col Trains: 1 truck (light).

**KStN 741**  
1.10.1937

**Motorized Light Engineer Column**

Col Hqs: 1 mcl; 1 mcl w/sc; 1 car (light).  
 1 Plt: 1 mcl; 1 mcl w/sc; 6 trucks (medium); 2 trailers (2-wheel w/ air compressor).  
 1 Plt: 1 mcl; 1 mcl w/sc; 7 trucks (medium); 1 ambulance (31).  
 Col Trains: 1 mcl; 1 truck (light).

**NOTES:**

On 1.09.1939, the *SS-Pionier-Sturmbann Dresden* was attached to the XV. Army Corps.

**SS-NACHRICHTEN-STURMBANN (MOTORISIERT)**  
**SS Motorized Signal Battalion**

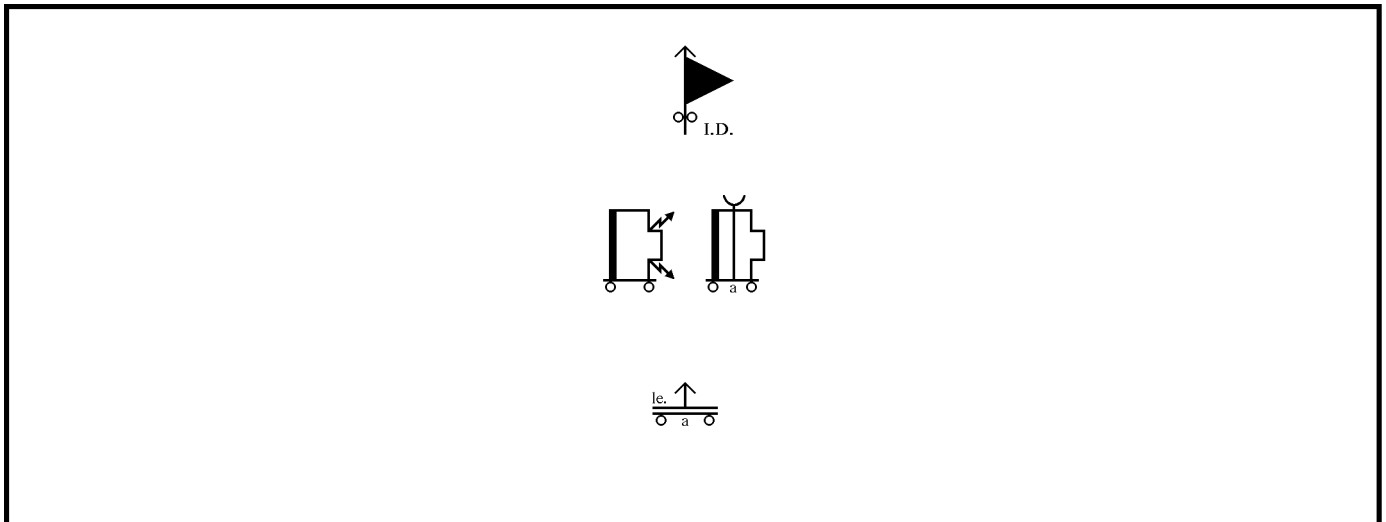

- KStN 807**  
1.10.1937      **Headquarters, Motorized Divisional Signal Battalion**  
Bn Hqs: 2 mcl; 3 cars (15); 2 trucks (1.5-ton).
- KStN 871 \*)**  
1.10.1937      **Motorized Light Signal Column "a" / Infantry Division (motorized)**  
Col: 1 mcl w/sc; 1 car (light); 1 truck (light); 4 trucks (medium); 2 vans (42); 1 trailer (generator).
- KStN 832 \*)**  
1.10.1938      **Motorized Telephone Company "a" / Infantry Division (motorized)**  
Co Hqs: 1 mcl; 1 mcl w/sc; 1 car (15); 1 truck (1.5-ton).  
1st Plt: Hqs Sect: 2 mcl; 1 car (15).  
3 Tele Ops Sect *a*: 1 car (15); 1 van (17).  
4 Lt Tele Sect *b*: 1 car (15).  
2nd Plt: Hqs Sect: 2 mcl; 1 car (15).  
4 Hvy Tele Sect *a*: 1 car (2); 1 van (23).  
3rd Plt: Hqs Sect: 2 mcl; 1 car (15).  
4 Hvy Tele Sect *a*: 1 car (2); 1 van (23).  
4th Plt: Hqs Sect: 2 mcl; 1 car (15).  
4 Hvy Tele Sect *a*: 1 car (2); 1 van (23).  
Co Trains: 1 car (15); 3 trucks (light); 2 trucks (medium).
- KStN 858 \*)**  
1.10.1938      **Motorized Radio Company / Infantry Division (motorized)**  
Co Hqs: 1 mcl; 1 mcl w/sc; 1 car (15); 1 truck (1.5-ton).  
1st Plt: Hqs Sect: 2 mcl; 1 car (15).  
5 Med Radio Sect *a*: 1 car (15); 1 van (17).  
2 Lt Radio Sect *c*: 1 van (17/1).  
2 Pack Radio Sect *b*: 1 car (2/2).  
2nd Plt: Hqs Sect: 2 mcl; 1 car (15).  
10 Lt Radio Sect *d*:  
3rd Plt: Hqs Sect: 2 mcl; 1 car (15).  
4 Pack Radio Sect *d*: 1 car (2/2).  
2 Pack Radio Sect *b*: 1 car (2/2).  
1 Radio Interception Sect: 1 van (76).  
1 Radio Listening Sect: 1 van (76).  
1 Code Sect: 2 cars (15).  
Co Trains: 1 car (15); 3 trucks (light); 3 trucks (medium); 1 van (42); 1 trailer (generator).

**NOTES:**

On 1.09.1939, the *SS-Nachrichten-Sturmbann* was attached Panzer-Verband Kempf.

## SOURCES AND REFERENCES

## UNPUBLISHED

<b>Bundesarchiv-Militärarchiv in Freiburg/Br.</b>		<b>National Archives and Records Administration, Washington, D.C.</b>
RHD 4/272	“Taktische Zeichen des Heeres, mit Anhang: Zeichen der Luftwaffe” Oberkommando des Heeres, 1938	T312/ 39 “Kriegsgliederung der 8. Armee” A.O.K. 8
RHD 11/1–53	“Kriegstärkenachweisungen”	T312/ 116 “Kriegsgliederung der 4. Armee aufgrund Armeebefehl Nr. 3” A.O.K. 4
RHD 18/27	“Besondere Anlage 2 A zum Mob. Plan (Heer) – 1939/1940” = Soll an Kopffzahl, Tiere, Fahrzeuge, Kraftfahrzeuge =	T312/ 477 “Befehlsgliederung A.O.K. 14 ab 30.8.” A.O.K. 14/Abt. Ia Nr. 64/39, Secret, dated 29.08.1939
RHD 18/28	“Besondere Anlage 2 A zum Mob. Plan (Heer) – 1939/1940” = Soll an Waffen =	T312/ 477 “Armeebefehl für die Befehlsübernahme durch Gen.Kdo. XXII. AK und XVIII. AK” A.O.K. 14/Abt. Ia Nr. 76/39, Secret, dated 31.08.1939
RHD 18/29	“Besondere Anlage 2 A zum Mob. Plan (Heer) – 1939/1940” = Soll an Munition =	T314/ 550 “Befehl für die Negugliederung der 10. Armee” A.O.K. 10/Abt. Ia Nr. 100/39, Secret, dated 27.08.1939
RHD 18/46	“Besondere Anlage 8 zum Mob. Plan (Heer) – 1939/1940” = Gültigkeitsliste der Kriegstärke- und Ausrüstungsnachweisungen =	T314/ 660 “Kriegsgliederung der 3. Armee” A.O.K. 3
RHD 18/50a	“Kriegsgliederung des Feldheeres, Stand 15.01.1940”	T398/430 “Kriegsgliederung des Heeres-Gruppenkommandos ‘Süd’” Generalstab des Heeres, Organisationsabteilung
RH 14/42	“Umgliederung von mot. Verbände” OKH/BdE/AHA/Org Abt I/Nr. 600/39, geh., dated 1.10.1939	
RH 14/42	“Umgliederung von mot. Verbände” OKH/BdE/AHA/AHA Ia(I)/Nr. 7857/39, geh., dated 12.10.1939	

## PUBLISHED

CHAMBERLAIN, P., DOYLE, H.C., JENTZ, T. “Encyclopedia of German Tanks of World War II” Arco Publishing, New York, 1978.	KOSAR, F. “Leichte Feldgeschütze” Lehmanns, Munich, 1971.	— “Die deutschen Geschütze 1939 - 1945” 2nd Edition Bernard & Grafe, Bonn, 1966
EMDE, J. “Die Nebelwerfer” DIECKHOFF, G. Podzun-Pallas, Friedberg, 1979.	— “Mittlere Feldgeschütze” Lehmanns, Munich, 1973.	SPIELBERGER, W. “Die Panzerkampfwagen I und II und ihre Abarten” Motorbuch, Stuttgart, 1974.
DOYLE, H.C., and KLIMENT, C.K. “Czechoslovak Armored Fighting Vehicles: 1918 – 1945” Bellona, Watford, Herts., 1979.	— “Schwere Geschütze und Eisenbahngeschütze” Bernard und Graefe, Munich, 1978.	— “Der Panzerkampfwagen III und seine Abarten” Motorbuch, Stuttgart, 1974.
ENGELMANN, J. “Das Buch der Artillerie, 1939 – 1945” Podzun-Pallas, Friedberg, 1983.	— “Infanteriegeschütze und Rückstossfreie Leichtgeschütze” Motorbuch, Stuttgart, 1979.	— “Die gepanzerten Radfahrzeuge des Deutschen Heeres” Motorbuch, Stuttgart, 1974.
ENGLEMANN, J., and SCHEIBERT, H. “Deutsche Artillerie, 1934 – 1945” Starke, Limburg/Lahn, 1974.	MEHNER, K. “Die Deutsche Wehrmacht 1939 – 1945” = Führung und Truppen = Militair-Verlag Patzwall, Norderstedt, 1993.	— “Der Panzerkampfwagen IV und seine Abarten” Motorbuch, Stuttgart, 1975.
ERB, H. “Kradgeschütze” Motorbuch, Stuttgart, 1981.	Militärgeschichtliches Forschungsamt “Das Deutsche Reich und der Zweiten Weltkrieg” Deutsche Verlags-Anstalt, Stuttgart, 1978 – 1990.	— “Die Halbkettenfahrzeuge des Deutschen Heeres” Motorbuch, Stuttgart, 1976.
FRANK, R. “Lastkraftwagen der Wehrmacht” Podzun-Pallas, Friedberg/H., 1992.	MUELLER-HILLEBRAND, B. “Das Heer 1933-1945” E.S. Mittler, Frankfurt/Main, 1954 – 1969.	— “Die Motorisierung der Deutschen Reichswehr, 1920 – 1935” Motorbuch, Stuttgart, 1979.
— “Personenkraftwagen der Wehrmacht” Podzun-Pallas, Friedberg/H., 1993.	NEHRING, W. “Die Geschichte der deutsche Panzerwaffe 1916 – 1945” Motorbuch, Stuttgart, 1974.	— “Die Panzer-Kampfwagen 35(t) und 38(t) und ihre Abarten einschließlich der tschechoslowakischen Heeres-motorisierung, 1920 – 1945” Motorbuch, Stuttgart, 1980.
GANDER, T.J. “Field Rocket Equipment” Almark, London, 1972.	— “Die deutschen gepanzerten Truppen bis 1945” Maximilian, Herford, 1965.	STÖBER, H. “Die Flugabwehrverbände der Waffen-SS” Schütz, Preus. Oldendorf, 1984.
HAHN, J. “Waffen und Geheimwaffen des deutschen Heeres, 1933 – 45” Bernhard und Graefe, Koblenz, 1986/87.	NIEHAUS, W. “Die Nachrichtentruppen 1914 bis heute” Motorbuch, Stuttgart, 1980.	TESSIN, G. “Verbände und Truppen der Deutschen Wehrmacht und Waffen-SS im Zweiten Weltkrieg” E.S. Mittler, Frankfurt/Main, 1965 – 1970. Biblio, Osnabrück, 1972 – 2002.
JENTZ, T. “Panzertruppen 1933 – 1942” Schiffer Military History, Atglen, PA, 1996.	OSWALD, W. “Kraftfahrzeuge und Panzer der Reichswehr, Wehrmacht und Bundeswehr” 11th Edition Motorbuch, Stuttgart, 1982.	TM-E 30-451 “Handbook on German Military Forces” War Department, Washington, D.C., 15 March 1945.
KAMPE, H.-G. “Die Heeres-Nachrichtentruppen der Wehrmacht 1939 – 1945” Podzun-Pallas, Wölfersheim-Berstadt, 1994	PAWLAS, K.L. “Datenblätter für Heeres-Waffen, Fahrzeuge und Gerät 1944” (Dokumentenat W 127) Karl L. Pawlas, Nürnberg, 1976.	Zentral Museum & Zentralarchiv der Pioniere “Deutsche Pioniere 1939 – 1945” Kurt Vowinkel, Neckargemünd, 1976.
KEILIG, W. “Das Deutsche Heer 1939-1945” [Loose-leaf collection, issued periodically.] Podzun, Bad Neuheim, 1956 onwards.	PETTER, D.P. “Pioniere - Entwicklung einer deutsche Waffengattung” Wehr & Wissen, Darmstadt, 1963.	
KOCH, H.A. “Flak” Podzun, Bad Nauheim, 1965.	Von SENGER und ETTERLIN, F.M. “Die Panzergrenadiere” Lehmanns, Munich, 1961.	

# INTRODUCTION TO GERMAN SOFT-SKINNED MOTOR VEHICLES

## Identification and Numbering System

The German Wehrmacht identified its motor vehicles by make, by type, by load, by mobility, by purpose, by number of seats, and/or by number. The latter, *Kraftfahrzeug (Kfz.)* and *Sonder Kraftfahrzeug (Sd.Kfz.)* numbers, indicated the purpose but not manufacturer of the vehicle. Early in the war, this series of numbers were reasonably well adhered to, although some vehicles were only classified by their load and mobility. As the war continued, the numbering system fell into disuse. The details of the numerical classifications are given on the next pages. The classifications were:

### *Kfz. No. Nomenclature*

- 1 – 10 light personnel carriers (*le. PKW*)
- 11 – 20 medium personnel carriers (*m. PKW*)
- 21 – 30 heavy personnel carriers (*s. PKW*)
- 31 – 40 light load carriers (*le. LKW*)
- 41 – 50 medium load carriers (*m. LKW*)
- 51 – 60 heavy load carriers (*s. LKW*)
- 61 – 70 light cross-country load carriers (*le. gl. LKW*)
- 71 – 80 medium cross-country load carriers (*m. gl. LKW*)
- 81 – 90 heavy cross-country personnel carriers (*s. gl. PKW*),  
and, light cross-country load carriers (*le. gl. LKW*)

The heavy personnel carrier and the light load carrier had the same numbers. Same chassis, different bodies.

Classifications did not always correspond to the actual usage. Mobility for personnel and load carriers, whether military or commercial versions, was defined either as cross-country (indicated by the prefix “*geländegängig*”, abbreviated to “*gl.*”, i.e. cross-country), or road-bound, in which case either the suffix “*(o.)*” was added, or the suffix was omitted altogether.

Commercial vehicles could be directly purchased from the manufacturer, or, upon mobilization, requisitioned from the civilian economy. Indeed 63% of all motor vehicles in the German Army were requisitioned by September 1939.

## German Load Carriers

Load carriers came in two versions (truck, i.e. open/with a bed; and van, i.e. closed/with a body instead of a bed), and in two types (commercial and military). As indicated above, the Germans used both numbered and unnumbered series of load carriers. Load carriers with and without “*Kfz.*” numbers came in three different load classifications:

- Light up to 2-ton
- Medium 3-ton
- Heavy 4.5-ton and over.

Load carriers with over a 5-ton load factor were only bought in the commercial versions.

## German Commercial Load Carriers in Military Use

<b>up to 2-ton (light)</b>	Adler	W61
	Borgward	L1400
	Daimler-Benz	L1500, L1500S, L1500A
	Phanomen	Granit 25H; 1500S, 1500A
	Opel	Blitz 2,5-32
	Steyr (Ost. Daimler)	1500A/01, 1500A/02, 2000A
<b>3-ton (medium)</b>	Borgward	B3000S, B3000A
	Daimler-Benz	L3000, L3000S, L3000A
	Ford	G21T; V3000, V3000S
	KHD (Magirus)	3000S, 3000A
	MAN	E2; E3000
	Opel	Blitz 3,6-36S, Blitz 6700A
<b>4.5-ton (heavy)</b>	Büssing-NAG	4500S, 4500A
	Daimler-Benz	L4500S, L4500A
	Gräfe & Stift	V7DW
	MAN	ML4500S, ML4500A
<b>6.5-ton</b>	Büssing-NAG	6500
	Daimler-Benz	L6500
	Krupp	LD6,5
	MAN	F4
	Vomag	6LR-647, 6LR-652
	Tatra	6500A
<b>9-ton</b>	Büssing-NAG	801, 802
	Faun	L9000D567

## German Personnel Carriers

Personnel carriers, with or without numbers, were also classified according to their mobility and engine size:

- Light up to 1500cc
- Medium up to 3000cc
- Heavy over 3000cc

Personnel carriers were either civilian or military. Civilian and later also military vehicles were identified by the engine size – and sometimes the number of seats.

## German Motorcycles

There were a multitude of motorcycle types in the German Army, classified according to engine size:

- Light up to 350cc
- Medium up to 500cc
- Heavy over 500cc

Motorcycles came in solo and sidecar versions. For the heavy motorcycles with sidecars, the sidecar wheel was power-driven. Some motorcycles had a light machine-gun mounted on the sidecar. The side cars were also used to carry light mortars, ammunition, as well as personnel.

## The Einheits-Vehicle-Program

The Einheits Program was an attempt by the German Armed Forces in the 1930s to produce a series of standardized vehicles. They were based on complicated 4 x 2, 4 x 4, and 6 x 4 chassis, with varying bodies, each conceived for a specific role.

Four chassis were finally produced. They were designated the light (*le. E-PKW*), the medium (*m. E-PKW*), as well as the heavy (*s. E-PKW*) personnel carriers. The fourth was the light load carrier (*le. E-LKW*, also known as the “*Einheits-Diesel*”). This light load carrier, produced between 1937 and 1940, had a 6 x 6 chassis capable of transporting 2.5-tons, and was powered by a diesel engine, (one of the few WWII German vehicles so powered).

Early Einheits-PKW all had stub axles on both sides for the spare wheels, which were supposed to assist the vehicles in crossing rough terrain. This feature was dropped in later models.

Light load carrier chassis were also fitted with passenger bodies. A typical example of this was the *le. Einheits-LKW*, and later the Steyer 1500.

The Einheits Vehicle Program ran into considerable difficulties owing to production and maintenance complications. The design proved too sophisticated for field use, where maintenance and spare parts were in short supply. The complicated two-axle steering caused particular problems in maintenance. The *le. Einheits-LKW* proved the only one that was a successful design.

## The Schell Vehicle Program

The Einheits Program could not meet the motor vehicle needs of the German Armed Forces. In 1938, the Schell Program was initiated. It standardized the number of Einheits vehicles at four, (see paragraph above), and provided a limited number of alternative commercial vehicles with all-wheel drive. It reduced the large variety of models in both commercial and military production from 113 to 30 load carriers, from 52 to 10 personnel carriers, and from 150 to 30 motorcycles, which, as an added benefit, enabled the German Army to commandeer civilian vehicles in time of need without drastically complicating the replacement and spare parts situation. The Schell Program vehicles did not always have the engine performance required for military use.

Neither the Einheits nor the Schell Programs provided enough vehicles for the expanding German Armed Forces. However, no solution was ever found for this problem, and Germany was severely handicapped by a lack of motor vehicles in World War II. Even the incorporation of captured enemy vehicles and the production facilities of occupied countries was unable to remedy this problem.

## The Raupenschlepper Ost (RSO)

The Russian Campaign quickly demonstrated that German wheeled vehicles were totally inadequate when it came to moving through mud and snow. This lack of good cross-country mobility led to the development of the Raupenschlepper Ost, created to meet the needs of the infantry for a fully-tracked motor vehicle that could move in all terrain. It was ideal also because it did not move very much faster than the marching infantry. This family of vehicles was produced without the standard identifying numbers being allocated.

## The Maultier

The lack of good cross-country mobility also led to field improvisations. One of which was so successful that it was produced in large amounts by German industry. The Maultier was basically a truck with tracks and drive train components similar to that of a light tank instead of a rear axle and wheels. The Germans produced two weight classes, namely the Sd.Kfz. 3 based on the medium truck, (initially with a 2-ton payload, then increased to 3 tons) and the Sd.Kfz. 3/5, based on the 4.5-ton truck, (initially with a 4-ton payload, then increased to 4.5 tons).

## The Schwere Wehrmachtsschlepper

A simplified and standardized 6-ton halftrack began production in late 1943. Production was low, with only 1000 being produced during the war.

**GERMAN NUMBERED MOTORIZED SOFT-SKINNED VEHICLES**

<b>Kfz.</b>	<b>German Nomenclature</b>	<b>Description</b>	<b>Makes &amp; Models</b>
1	le gl PKW (‘Kübelwagen’)	light cc personnel carrier (3 and 4-seater)  Hanomag - all models	le. Einheits-PKW BMW 303, 309, 315, 319, 3/15, 4/20PS Daimler-Benz 170-V Dixie 3/15  Opel P-4 Skoda Popular 1100 Steyr 250 Volkswagen Type 82, 87, etc.
1/20	le gl schwimm-PKW	light amphibious cc personnel carrier (4-seater)	Volkswagen Type 128 and 166
2	le Nachrichten-Kw	light cc signals carrier	le. Einheits-PKW
2/1	le Fernsprech-Kw	light cc telephone carrier	BMW 309, 319, 3/15, 4/20
2/2	le Funk-Kw	light cc radio carrier	Hanomag - all models
2/40	le Instandsetzungs-Kw	light cc maintenance section carrier (all 2 seaters with equipment storage in the back)	Daimler-Benz 170-V Volkswagen Type 82, 87, etc.
3	le Messtrupp-Kw	light cc calibration section carrier	le. Einheits-PKW BMW 309 Daimler-Benz 170-V Steyr 250 Volkswagen Type 82, 87, etc.
4	le Truppen-Luftschutz-Kw	light cc anti-aircraft carrier (dual MG)	le. Einheits-PKW
5	m gl Kessel-Kw	medium cc tanker	m. Einheits-PKW
11	m gl PKW	medium cc personnel carrier	m. Einheits-PKW
12	m gl PKW mit Zughaken	medium cc personnel carrier with towing hook (for 37mm ATG, 75mm IG, ammo trailers)	Adler 12N, 3-Gd Daimler-Benz 200, 260, 290, 320 Phänomen Granit 25 Wanderer W-11, W-23S
13	m gl gp PKW (MG)	early armored medium cc car (with one MG)	Adler Standard 6
14	m gl gp PKW (Funk)	early armored medium cc radio car (no armament)	
15	m gl PKW	medium cc personnel carrier	m. Einheits-PKW
15	m gl PKW mit Gerätkasten	medium cc carrier with equipment boxes	Auto Union / Horch 830-R
15/1	m gl Nachrichten-Kw	medium cc signals carriers	Daimler-Benz 340-WK, L1500A
15/1	m gl Fernsprech-Kw	medium cc telephone carrier	Horch 830-R, 830-BL
15/2	m gl Funk-Kw	medium cc radio carrier	Steyr 250
15/4	m gl Funk-Kw	medium cc radio carrier	Stoewer M-12-RW
15/5	m gl Funk-Kw	medium cc radio carrier	
15/6	m gl Funk-Kw	medium cc radio carrier	
15/7	m gl Funk-Kw	medium cc radio carrier	
17	m gl Fernschreibe-Kw	medium cc telex carrier	
16	m gl Meßstelle-Kw	medium cc calibration station carrier	
16	m gl Meßtrupp-Kw	medium cc calibration section carrier	
16/1	m gl Vorwarner-Kw	medium cc advanced warning section carrier	
17	kl Verstärker-Kw	small cc amplifier van	m. Einheits-PKW
17	kl Kabelmess-Kw	small cc wire calibration van	Auto Union / Horch 830-R
17	kl Fernsprechbetriebs-Kw	small cc telephone operations van	
17/1	kl Funktrupp-Kw	small cc radio section van	
17/2	kl Fernsprechtrupp-Kw	small cc telephone section van	
17/3	kl Funk-Kw	small cc radio van	
18	s gl PKW	heavy cc personnel carrier	m. Einheits-PKW
18	Gefechts-Kw (mit Gerätkasten & Zughaken)	heavy cc carrier (combat) (with equipment boxes and towing hook)	s. Einheits-PKW Daimler-Benz 200, L1500A Wanderer W 11, W 14
19	Fernsprechbetriebs-Kw	cc telephone exchange van	Krupp L2H-43, Krupp L2H-143
	Fernsprech-Kw	cc telephone van	
	Funk-Kw	cc radio van	
21	s gl PKW (Kommandeurwagen)	heavy cc staff car (sedan or cabrio)	Daimler-Benz G-4 Krupp L2H-143 Cabrio Steyr 640, 1500A Praga Skoda
23	Fernsprech-Kw	cc telephone equipment van	s. Einheits-PKW
24	Verstärker-Kw	cc amplifier equipment van	
31	Sanitäts-Kw (‘Sanka’) [also: Kranken-Kw (‘KrKw’)]	cc ambulance van	s. Einheits-PKW Phänomen Granit 25H Steyr 640, 1500A Adler W-61K Daimler-Benz L1000, L1500E Ford G917, G987, 997, V3000S, V3000A
42	Sammler-Kw	generator / accumulator / battery van	Krupp L3-M42
	Sammlerwerkstatt-Kw	generator repair van	m. LKW (o.)
	Nachrichtenwerkstatt-Kw	signals repair van	
	Werkstatt-Kw	workshop van	
43	Flakauswert-Kw	anti-aircraft evaluation van	
44	Sauer- und Stickstoff-Erzeugungs-Kw	Oxygen and Nitrogen generation van	
51	Werkstatt-Kw	workshop van	m. LKW (o.) s. LKW (o.)

**NOTES:**

The early armored cars (*Kraftfahrzeug 13* and *14*) were obviously not soft-skinned vehicles. It is not clear why they were included within this listing and not in the special military motor vehicle (*Sonderkraftfahrzeug*) listing.

**GERMAN NUMBERED MOTORIZED SOFT-SKINNED VEHICLES**

<b>Kfz.</b>	<b>German Nomenclature</b>	<b>Description</b>	<b>Makes &amp; Models</b>
61	gr Nachrichten-Kw gr Schlüssel-Kw gr Funk-Kw gr Funkbetriebs-Kw gr Fernsprechbetriebs-Kw gr Fernschreib-Kw gr Verstärker-Kw gr Peil-Kw gr Meßtrupp-Kw	large cc signal van large cc code van large cc radio van large cc radio operations van large cc telephone operations van large cc telex van large cc amplifier van large cc sound-ranging equipment van large cc calibration section van	Einheits-Diesel Daimler-Benz G-3a, LG 3000 Büssing-NAG G-31, G500A, G500S, 4500S, 4500A Magirus M-206, M-30, S3000, A3000 Borgward G.W., B3000S, B3000A
61/1	gr Funk-Kw	large cc radio van	
62	gr Nachrichten-Kw gr Fernsprechbetriebs-Kw gr Funk-Kw gr Wetter-Kw gr Druckerei-Kw gr Schall-Aufnahme-Kw gr Schall-Auswertungs-Kw gr Vermessung-Auswertungs-Kw gr Licht-Auswertungs-Kw gr Stabs-Auswertungs-Kw	large cc signals van large cc telephone operations van large cc radio van large cc weather van large cc printing van large cc sound recording van large cc sound evaluation van large cc calibration evaluation van large cc flash evaluation van large cc evaluation command van	
63	gr Nachrichten-Kw gr Meß-Stellen- und Gerät-Kw gr Vermessungs-Gerät-Kw gr Lichtmeß-Stellen-Kw gr Lichtmeß-Gerät-Kw gr Schallmeß-Stellen-Kw gr Schallmeß-Gerät-Kw gr Vorwarner-Kw gr Vermessungsgerät-Kw	large cc signals van large cc calibration station and equipment van large cc calibration equipment van large cc flash ranging station van large cc flash ranging equipment van large cc sound ranging station van large cc sound ranging equipment van large cc advanced warning equipment van large cc calibration equipment van	
68	Funkmast-Kw Fernsprech-Kw	cc radio antenna van cc telephone carrier	Einheits-Diesel Krupp L2H-43, L2H-143 Magirus M-206 Opel Blitz A
68/1	Funkmast-Kw	cc radio antenna van	
69	Protz-Kw	cc prime-mover for light guns	s. Einheits-PKW
70	Mannschafts-Kw	cc personnel carrier	Krupp L2H-43, L2H-143
71	Truppen-Luftschutz-Kw s Truppenluftschutz-Kw	cc anti-aircraft carrier heavy cc anti-aircraft carrier	Mercedes-Benz L1500A
72	Fernsprechbetriebs-Kw Fernsprech-Vermittlungs-Kw Fernschreib-Kw Fernschreib-Vermittlungs-Kw Verstärker-Kw Funk-Kw (a & b) Funkbetriebs-Kw Funkhorch-Kw Befehls-Kw Druckerei-Kw m Wetter-Kw	cc telephone operations van cc telephone exchange van cc telex van cc telex exchange van cc amplifier van cc radio van cc radio operations van cc radio interception van cc command van cc printing van cc weather van	Henschel 33-D1 Magirus 33-G1 Krupp L3H-63, L3H-163 Büssing-NAG III GL6
72/1	Fernschreib-Kw	cc telex van	
74	Flak-Meßtrupp-Kw I & II	cc anti-aircraft calibration section van	
76	Beobachtungs-Kw	cc observation carrier	Daimler-Benz G-3a
77	Feldkabel-Kw Fernsprech-Kw Fernsprechbau-Kw	cc field cable carrier cc telephone carrier cc telephone construction carrier	Büssing-NAG G-31 Magirus M-206
79	Werkstatt-Kw	cc workshop van	Henschel 33-D1 Magirus 33-G1 Krupp L3H-63, L3H-163
81	le Flak-Kw	cc prime-mover for light anti-aircraft guns	s. Einheits-PKW
83	le Scheinwerfer-Kw I & II	cc prime-mover for light searchlights, with generator	Krupp L2H-42, L2H-143
92	Mannschaft-Entgiftungs-Kw	cc personnel decontamination van	Henschel 33-D1, 33-G1
93	Bekleidungs-Entgiftungs-Kw	cc clothing decontamination van	
94	Wasser-Kw (Kessel)	cc decontamination van (hot water shower)	
95	Kammer-Kw	unit stores van	m. LKW (o.)
100	Drehkran 3 – 5 ton	3 – 5-ton revolving crane on cc carrier	s. gl. LKW (4,5-ton)

**Abbreviations and Definitions:**

“Carrier”	indicates an open vehicle, covered by a canvas top.
“Truck”	indicates a cargo vehicle with an open payload area, covered by a canvas top.
“Van”	indicates a cargo vehicle with a fully or partially enclosed payload area (body).
“Prime-Mover”	indicates a vehicle for towing equipment, usually modified and adapted for that equipment.
“Sedan”	indicates a passenger vehicle (car) with a closed body.
“Cabrio”	indicates an open passenger vehicle (car) covered by a canvas top.
“cc”	indicates a vehicle with cross-country capability.

A	<i>Allrad</i> : all-wheel-drive version. (Makers identification).
S	<i>Steuerermässigt</i> : (taxed reduced) qualified for 33% motor vehicle tax reduction, introduced as incentive to increase demand for off-road capable trucks.
(o.)	<i>(ohne handelsüblich)</i> : commercial vehicle.
Kfz.	<i>Kraftfahrzeug</i> : commercially available chassis and drive train with military body.
Sd.Kfz.	<i>Sonderkraftfahrzeug</i> : specially military body and chassis.
le. / lei.	<i>leicht</i> : light
m.	<i>mittler</i> : medium
s.	<i>schwer</i> : heavy
LKW	<i>Lastkraftwagen</i> : load (cargo) motor vehicle (truck or van)
PKW	<i>Personenkraftwagen</i> : personnel (passenger) motor vehicle (car)
gl.	<i>geländegängig</i> : cross-country
Kw.	<i>Kraftwagen</i> : motor vehicle
kl.	<i>klein</i> : small/light
gr.	<i>gross</i> : large/heavy
gp.	<i>gepanzert</i> : armored
wg.	<i>wassergängig</i> : amphibious
schw.	<i>schwimmfähig</i> : amphibious (alternate)



## GERMAN SPECIAL MILITARY VEHICLES

Sd.Kfz. No.	German Designation « German Abbreviation »	Description Main Armament [Ammunition carried]
2	Kleines Kettenrad « KK »	0.5-ton light halftrack n/a
2/1	Kleines Kettenrad (Feldfern-kabel) « KK (FFK) »	0.5-ton halftrack with telephone cable n/a
2/2	Kleines Kettenrad (schwere Feldfern-kabel) « KK (s. FFK) »	0.5-ton halftrack with heavy telephone cable n/a
3	Gleisketten-Lastkraftwagen 2-ton (Maultier) « 2-ton Maultier »	halftracked 2-ton truck n/a
3/4	Gleisketten-Lastkraftwagen 2-ton (Maultier) (Krankenwagen) « 2-ton Maultier (KrKw) »	halftracked 2-ton ambulance n/a
3/5	Gleisketten-Lastkraftwagen 4.5-ton (Maultier) « 4.5-ton Maultier »	halftracked 4.5-ton truck n/a
4	Gleisketten-Lastkraftwagen 3-ton (Maultier) gepanzert (Munitionskraftwagen) « gep. Maultier (muni) »	armored halftracked truck for ammunition transport [transports 20 150mm rockets]
4/1	15cm Panzerwerfer 43 « Pz.Werf. 43 »	armored halftracked truck with rocket launcher 150mm rocket launcher (10 tubes) [20]
6	mittlerer Zugkraftwagen 5-ton (Pionier-Ausführung) « m. Zgkw. 5t (Pion. Ausf.) »	5-ton halftrack (engineer version) n/a
6/1	mittlerer Zugkraftwagen 5-ton (Artillerie-Ausführung) « m. Zgkw. 5t (Artl. Ausf.) »	5-ton halftrack (artillery version) n/a
6/2	3,7cm Flak 36 auf Fahrgestell m. Zugkraftwagen 5-ton « 3,7cm Flak (Sfl) auf lei. Zgkw. 5 t »	self-propelled medium antiaircraft gun on 5-ton halftrack 37mm Flak 18 or 36 [?]
7	mittlerer Zugkraftwagen 8-ton « m. Zgkw. 8t »	8-ton halftrack n/a
7/1	2cm Flakvierling auf Fahrgestell mittlerer Zugkraftwagen 8-ton « 2cm Flakvierl. (Sf) auf Zgkw. 8t »	self-propelled light quad antiaircraft gun on 8-ton halftrack 20mm quad Flak38 L/112.5 [600]
7/2	3,7cm Flak 36 /Sfl) auf Fahrgestell mittlerer Zugkraftwagen 8-ton « 2cm Flakvierl. (Sf) auf Zgkw. 8t »	self-propelled antiaircraft gun on 8-ton halftrack 37mm Flak 36 L/98 [?]
7/6	mittlerer Zugkraftwagen 8-ton (Flakmess) « Zgkw. 8t Flak-Mess »	8-ton halftrack for antiaircraft calibration equipment n/a
8	schwerer Zugkraftwagen 12-ton « s. Zgkw. 12t »	12-ton halftrack n/a
8	8,8cm Flak (Sf) auf gepanzertem Zugkraftwagen 12-ton « 8,8cm Flak (Sf) auf gep. Zgkw. 12t »	self-propelled heavy antiaircraft gun on armored halftrack 88mm Flak L/56 [40]
9	schwerer Zugkraftwagen 18-ton « Zgkw. 18t »	18-ton halftrack n/a
9/1	schwerer Drehkranwagen (Hebekraft 6 ton) « s. Drehkran (6 t) »	18-ton halftrack with 6-ton revolving crane (manufactured by Bilstein) n/a
9/2	schwerer Drehkranwagen (Hebekraft 10 ton) « s. Drehkran (10 t) »	18-ton halftrack with 10-ton revolving crane (manufactured by Demag) n/a
10	leichter Zugkraftwagen 1-ton « lei. Zgkw. 1t »	1-ton halftrack n/a
10/1	leichter Gasspürwagen « lei. Zgkw. (Gas-Spür) »	1-ton halftrack, light gas detection vehicle with sprinkler n/a
10/2	leichter Entgiftungskraftwagen « lei. Zgkw. (Entg.) »	1-ton halftrack, light decontamination vehicle n/a
10/3	leichter Sprühkraftwagen « lei. Zgkw. (Sprüh) »	1-ton halftrack, light bulk decontamination vehicle n/a
10/4	2cm Flak (Sf) auf Fahrgestell leichter Zugkraftwagen 1-ton « 2cm Flak (Sf) auf lei. Zgkw. 1t »	self-propelled light antiaircraft gun on 1-ton halftrack 20mm Flak 30 L/112.5 [280]
10/5	2cm Flak (Sf) auf gepanzertem Fahrgestell leichter Zugkraftwagen 1-ton « 2cm Flak (Sf) auf gp. lei. Zgkw. 1t »	self-propelled light antiaircraft gun on armored 1-ton halftrack 20mm Flak 38 L/112.5 [280]
11	leichter Zugkraftwagen 3-ton « lei. Zgkw. 3t »	3-ton halftrack n/a
11/1	Nebelkraftwagen « m. Zgkw. (Nebel) »	3-ton halftrack for towing rocket launchers n/a [10,5cm Nbl.W. 35: 80 rockets; 15cm Nbl.W. 41: 36 rockets; 28/32cm Nebelwerfer 41: 12 rockets plus launching frames]
11/2	mittlerer Entgiftungskraftwagen « m. Zgkw. (Entg.) »	3-ton halftrack, medium decontamination vehicle n/a
11/3	mittlerer Sprühkraftwagen « m. Zgkw. (Sprüh) »	3-ton halftrack, medium chemical spraying vehicle (bulk decontamination) n/a

## GERMAN SPECIAL MILITARY VEHICLES

Sd.Kfz. No.	---German Designation « German Abbreviation »	Description Main Armament [Ammunition carried]
11 /4	Nebelkraftwagen « m. Zgkw. (Nebel) »	3-ton halftrack for towing 15cm rocket launchers n/a [15cm Nbl.W. 41: 36 rockets; 21cm Nbl.W. 42: 10 rockets; 28/32cm Nebelwerfer 41: 4 rockets]
11 /5	Nebelkraftwagen « m. Zgkw. (Nebel) »	3-ton halftrack for towing 21cm rocket launchers n/a [15cm Nbl.W. 41: 36 rockets; 21cm Nbl.W. 42: 10 rockets]
35	Bergepanzer « Berge-Pz. »	armored recovery vehicle (T-34 or KV-I w/o turret) n/a
101	Panzerkampfwagen I « Pz. I »	light tank 2 MG 13 [1525 – 2250]
–	Panzerkampfwagen I, Ausf. F (n.A. verstärkt) « Pz. I, n.A. »	light tank, reinforced armor, Model F 2 MG 34 [2250]
–	4,7cm Pak(t)(Sf) auf Fahrgestell Panzerkampfwagen I « 4,7cm Pak(t) auf Pz-I; [also 4,7cm(t) (mot S)] »	self-propelled antitank gun on Pz-I chassis 47mm Pak(t) L/43.4 [86]
–	15cm sIG 33 auf Panzerkampfwagen I, Ausf. B « 15cm sIG33 auf Pz-I; [also 15cm sIG (mot S)] »	self-propelled heavy infantry gun on Pz-I chassis 150mm L/43.4 [?]
–	Pionier-Panzerwagen I « Pion-Pz. I »	Engineer vehicle (without turret) on Pz-I chassis n/a
111	Munitionsschlepper auf Fahrgestell Panzerkampfwagen I « Muni-Schlepper auf Pz-I »	armored ammunition carrier based on Pz-I chassis varied, depending upon ammunition type carried
121	Panzerkampfwagen II « Pz. II »	light tank 20mm KwK 30 L/55 [180]
122	Flamm-Panzer-II « Fl.Pz. II »	flame throwing tank on Pz-II basis [320 liters flame oil]
123	Panzerspähwagen II (Luchs 2cm) « lei. Pz-Späh. Wg. Luchs »	light, fully tracked recon tank on Pz-II basis 20mm KwK 38 L/55 [330]
123	Panzerspähwagen II (Luchs 5cm) « lei. Pz-Späh. Wg. Luchs »	light, fully tracked recon tank on Pz-II basis 50mm KwK L/60 [33]
124	lei. FH 18/2 Selbstfahrlafette auf Pz-II (Wespe) « Wespe »	self-propelled light field howitzer on Pz-II basis 105mm le FH 18/2 [32]
–	Munitions-Selbstfahrlafette auf Pz-II (Wespe) « Muni. Wespe »	armored ammunition carrier for Wespe on same chassis [transports 90 light field howitzer rounds]
–	Geschützwagen II für 15cm sIG « 15cm sIG (sfl) »	self-propelled heavy infantry gun 150mm L/43.4 [30]
–	Pionier-Panzerwagen II « Pion-Pz. II »	Engineer vehicle (without turret) on Pz-II chassis n/a
131	Panzer-Selbstfahrlafette für 7,5cm Pak 40/2 auf Fahrgestell Panzerkampfwagen II « Marder II; [also 7,5cm Pak 40 (Sf) auf Pz-II; also Pz Sf 2] »	self-propelled antitank gun on Pz-II chassis 75mm Pak L/43 [37]
132	Panzer-Selbstfahrlafette für 7,62cm Pak 36(r) auf Fahrgestell Panzerkampfwagen II « Marder II; [also 7,62cm Pak 36(r)(Sf) auf Pz-II; also Pz Sf 1] »	self-propelled antitank gun on Pz-II chassis (Models D and E) 76.2mm Pak(r) L/51.5 [30]
135	75mm Pak auf Lorraine-Schlepper (Marder I) « Marder I »	self-propelled heavy antitank gun on Lorraine basis 75mm s FH Pak 40/1 [?]
135 /1	s. FH 13/1 Selbstfahrlafette auf Lorraine-Schlepper « s.FH (sfl) auf Lorraine »	self-propelled heavy field howitzer on Lorraine basis 150mm s FH 13/1 [8]
–	Panzerkampfwagen 35 (t) « Pz-35(t) »	Czech medium tank (designation changed from LTM 35 on 16.01.40) 37mm A33 L/42 [72]
–	Panzerbefehlwagen 35 (t) « Pz-Bef-Wg 35(t) »	Czech medium command tank 37mm A33 L/42 [?]
–	Mörserwagen 35 (t) « Mörs.Wg. 35(t) »	tracked prime mover for heavy mortar on Czech medium tank basis n/a
–	Zugkraftwagen 35 (t) « Zgkw. 35(t) »	tracked prime mover based on Czech medium tank n/a
–	Panzerkampfwagen 38(t), Ausführung A – G « Pz-38(t) »	Czech medium tank (designation changed from LTM 38 on 16.01.40) 37mm A7 L/42 [90]
–	Panzerbefehlwagen 38(t) « Pz-Bef-Wg 38(t) »	Czech medium command tank 37mm A7 L/42 [?]
138	Panzerjäger 38(t), Ausf. H für 7,5cm Pak « Marder III »	self-propelled antitank gun on Pz-38(t) chassis 75mm Pak 40/3 L/48 [38]
138	Panzerjäger 38(t), Ausf. M für 7,5cm Pak « Marder III »	self-propelled antitank gun on Pz-38(t) chassis 75mm Pak 40/3 L/48 [27]
138	Munitionsfahrzeug für 15cm s.IG selbstfahrlafette « Muni. Fahrzeug für 15cm s.IG Sfl »	armored ammunition carrier for Bison on same chassis [transports 40 infantry gun rounds]

## GERMAN SPECIAL MILITARY VEHICLES

Sd.Kfz. No.	German Designation « German Abbreviation »	Description Main Armament [Ammunition carried]
138/1	s.IG auf Selbstfahrlafette 38(t) « s.IG (sfl) <i>Grille</i> »	self-propelled heavy infantry gun on Pz-38(t) chassis 150 sIG 33/1 L/11 [15]
138/2	Jagdpanzer 38 « <i>Hetzer</i> »	light tank destroyer on Pz-38(t) basis 75mm Pak 39 L/48 [41]
–	Flammpanzer 38 « Flamm-Pz 38 »	flame tank based on <i>Hetzer</i> hull [700 liters flame oil]
–	Bergepanzer 38 « Berge-Pz 38 »	recovery tank based on <i>Hetzer</i> hull n/a
–	15cm schwerer Infanteriegeschütz 33/2 auf Jagdpanzer 38 « 15cm sIG 33/2 auf PzJg 38(t) »	self-propelled heavy infantry gun based on <i>Hetzer</i> hull 150mm sIG 33/2 [?]
139	Panzerjäger 38(t) für 7,62cm Pak 36(r) « <i>Marder III</i> »	self-propelled antitank gun on Pz-38(t) chassis 76.2mm Pak(r) L/51.5 [30]
140	Flakpanzer 38 « Flak-Pz-38 »	Self-propelled anti-aircraft gun based on Czech Pz-38(t) 20mm Flak 38 [540]
140/1	Aufklärungspanzer 38(t) (2cm) « Aufkl-Pz-38(t) (2cm) »	Czech reconnaissance tank based on Pz-38(t) 20mm KwK 38 [108]
140/1	Aufklärungspanzer 38(t) (7,5cm) « Aufkl-Pz-38(t) (7,5cm) »	Czech reconnaissance support tank based on Pz-38(t) 75mm KwK 37 L/24 [?]
141	Panzerkampfwagen III, Ausführung A – G « Pz. III (3,7cm) »	medium tank, Models A – G 37mm KwK 35/36 L/45 [120]
141	Panzerkampfwagen III, Ausführung H – J « Pz. III (5cm); [also Pz-III (kz)] »	medium tank, Models H – J 50mm KwK L/42 [99]
141/1	Panzerkampfwagen III, Ausführung J – L « Pz. III (5cm); [also Pz-III (lg)] »	medium tank, Model J – L 50mm KwK L/60 [84 – 78]
141/2	Panzerkampfwagen III, Ausf. M – N « Pz. III (7,5cm) »	medium tank, Models M – N 75mm KwK 37 L/24 [84 – 64]
141/3	Flammpanzer III « Flamm-Pz. III »	medium flame-throwing tank [1020 liters flame oil]; MG [3750]
–	SturmInfanteriegeschütz 33B « St. Inf. Gesch. 33 »	self-propelled, armored heavy infantry gun on Sturmgeschütz basis 150mm Stu IG L/11 [30]
142	7,5cm Sturmgeschütz 40, Ausführung A – D « Sturmgeschütz III [also: Stu. Gesch. III] »	assault gun, Model A – D 75mm StuK 37 L/24 [44]
142	7,5cm Sturmgeschütz 40, Ausführung E « Sturmgeschütz III [also: Stu. Gesch. III] »	assault gun, Model E 75mm StuK 37 L/24 [50]
142	7,5cm Sturmgeschütz 40, Ausführung F « Sturmgeschütz III [also: Stu. Gesch. III] »	assault gun, Model F 75mm StuK 37 L/24 [44]
142/1	7,5cm Sturmgeschütz 40, Ausführung F8 – G « Sturmgeschütz III [also: Stu. Gesch. III] »	assault gun, Model F8 – G 75mm StuK40 L/43 [54]
142/2	7,5cm Sturmhaubitze, Ausführung F – G « Sturmhaubitze III [also: Stu. Haub. III] »	assault howitzer, Model F – G 105mm StuH 42 L/28 [36]
143	Panzer-Beobachtungswagen III « Pz. Beob. Pz. III »	armored artillery observation tank MG [2100]
161	Panzerkampfwagen IV, Ausführung A – F <sub>1</sub> « Pz. IV [also: Pz-IV(kz)] »	medium tank, Models A – F <sub>1</sub> 75mm KwK 37 L/24 [80]
161/1	Panzerkampfwagen IV, Ausführung F <sub>2</sub> – G « Pz. IV [also: Pz-IV(lg)] »	medium tank, Models F <sub>2</sub> – G 75mm KwK 40 L/43 [87]
161/2	Panzerkampfwagen IV, Ausführung H – J « Pz. IV [also: Pz-IV(lg)] »	medium tank, Models H – J 75mm KwK 40 L/48 [87]
161/3	Flakpanzer-IV « Flak-Pz 3,7cm [ <i>Ostwind</i> ] »	anti-aircraft tank 37mm Flak 43 L/98 [400]
161/4	Flakpanzer-IV « Flak-Pz 2cm-Vierling [ <i>Wirbelwind</i> ] »	anti-aircraft tank 20mm quad Flak 38 [1000]
–	Panzer-Flak Sfl IV « Pz-Flak IV [ <i>Möbelwagen</i> ] »	anti-aircraft tank 37mm Flak 43 L/98 [416]
162	7,5cm Pak 39 auf Fahrgestell Panzerkampfwagen IV « Jagdpanzer IV »	self-propelled heavy antitank gun on Pz-IV basis 75mm Pak 39 L/48 [79]
162/1	7,5cm StuK 42 auf Fahrgestell Panzerkampfwagen IV, Ausführung A « Panzer-IV/70 (A) »	tank destroyer on Pz-IV basis 75mm StuK 42 L/70 [55]
162/1	7,5cm StuK 42 auf Fahrgestell Panzerkampfwagen IV, Ausführung V « Panzer-IV/70 (V) »	tank destroyer on Pz-IV basis 75mm StuK 42 L/70 [55]

## GERMAN SPECIAL MILITARY VEHICLES

Sd.Kfz. No.	German Designation « German Abbreviation »	Description Main Armament [Ammunition carried]
163	7,5cm Sturmgeschütz IV « Sturmgeschütz IV [also: StuG IV] »	assault gun based on Pz-IV 75mm StuK40 L/48 [63]
164	8,8cm Pak 43/1 auf Fahrgestell Panzerkampfwagen III/IV (Hornisse) « Hornisse; [as of 1944: Nashorn] »	self-propelled heavy antitank gun on mixed Pz-III/IV basis 88mm Pak 43/1 L/71 [40]
165	s. Panzerhaubitze 18/1 auf Fahrgestell III/IV (Hummel) « Hummel »	self-propelled heavy field howitzer on mixed Pz-III/IV basis 150mm sFH 18/1 [18]
–	Munitionsfahrzeug für 15cm s. IG selbstfahrlafette « Muni. Fahrzeug für 15cm s.IG Sfl »	armored ammunition carrier for Hummel on same chassis [transports 60 heavy field howitzer rounds]
165 /1	leichte Feldhaubitze (Sfl)/Geschützwagen IVb « leFH (sfl) »	self-propelled light field howitzer on Pz-IV basis 105mm leFH 18/1 [60]
166	s. IG auf Panzerkampfwagen-IV Fahrgestell (Sturmpanzer) « Stu-Pz IV [aka <i>Brummbär</i> ] »	armored, self-propelled heavy infantry gun on Pz-IV chassis 150mm StuH 43 L/12 [38]
–	10,5cm Kanone 18 auf Panzer-Selbstfahrlafette IVa « 10,5cm K18 auf Pz-Sfl IVa »	self-propelled gun on Pz-IV chassis 105mm StuK 18/1 L/52 [25]
171	Panzerkampfwagen V (Panther), Ausführung D, A « Panther »	medium tank, Models D and A 75mm KwK 42 L/70 [79]
171	Panzerkampfwagen V (Panther), Ausführung G « Panther »	medium tank, Models G 75mm KwK 42 L/70 [82]
173	Jagdpanzer V « Jagdpanther »	tank destroyer on Panther basis 88mm Pak 43/3 L/71 [57]
179	Bergepanther « Berge-Pz-V »	armored recovery vehicle on Panther basis 20mm KwK 38 [?]
181	Panzerkampfwagen VI (Tiger I), Ausführung E « Tiger I »	heavy tank, Model E 88mm KwK 36 L/56 [92]
–	Panzer-Mörser 38cm auf VI (Tiger) « Sturmiger »	self-propelled heavy rocket launcher on Pz-VI(I) chassis 380mm rocket launcher [12]
182	Panzerkampfwagen VI (Tiger II), Ausführung B « Tiger II [aka <i>Königtiger</i> ] »	heavy tank 88mm KwK 43 L/71 [72–84]
184	Panzerjäger Tiger (P) für 8,8cm Pak 43 (Ferdinand) « Ferdinand; [later <i>Elefant</i> ] »	self-propelled, heavy antitank gun on prototype Pz-VI chassis 88mm StuK 43/1 L/71 [55]
186	schwere Panzerjäger, Ausführung B « Jagdtiger »	heavy tank destroyer 128mm Pak 44 L/55 [40]
221	leichter Panzerspähwagen (MG) « le. Pz-Späh. Wg. (MG) »	light armored car (4x4) MG [1020]
221	leichter Panzerspähwagen (schwere Panzerbüchse 41) « le. Pz-Späh. Wg. (sPzBü 41) »	light armored car (4x4) 28mm sPzBü 41 [180]
222	leichter Panzerspähwagen (2cm) « le. Pz-Späh. Wg. (2cm) »	light armored car (4x4) 20mm KwK 38 L/55 [180]
223	leichter Panzerspähwagen (Funk) « le. Pz-Späh. Wg. (Fu) »	light armored radio car (4x4) MG [1050]
231	schwerer Panzerspähwagen (2cm)(6-Rad) « s. Pz-Späh. Wg. (2cm) »	heavy armored car (6x4) 20mm KwK 30 L/55 [200]
232	schwerer Panzerspähwagen (Funk)(6-Rad) « s. Pz-Späh. Wg. (Fu) »	heavy armored radio car (6x4) 20mm KwK 30 L/55 [200]
231	schwerer Panzerspähwagen (2cm)(8-Rad) « s. Pz-Späh. Wg. (2cm) 8-Rad »	heavy armored car (8x8) 20mm KwK 30 L/55 [180]
232	schwerer Panzerspähwagen (Funk)(8-Rad) « s. Pz-Späh. Wg. (Fu) 8-Rad »	heavy armored radio car (8x8) 20mm KwK 30 L/55 [180]
233	schwerer Panzerspähwagen (7,5cm)(8-Rad) « s. Pz-Späh. Wg. (7,5cm) 8-Rad »	heavy armored radio car (8x8) 75mm StuK 37 L/24 [32]
234 /1	schwerer Panzerspähwagen (2cm) « Pz-Späh. Wg. (2cm) »	heavy armored car (8x8) 20mm KwK 30 L/55 [250]
234 /2	schwerer Panzerspähwagen (5cm) « Pz-Späh. Wg. (2cm) [aka <i>Puma</i> ] »	heavy armored car (8x8) 50mm KwK 39/1 L/60 [55]
234 /3	schwerer Panzerspähwagen (7,5cm) « Pz-Späh. Wg. (7,5cm) »	heavy armored car (8x8) 75mm K-51 L/24 [50]
234 /4	schwerer Panzerspähwagen (7,5cm Pak) « Pz-Späh. Wg. (7,5cm Pak) »	heavy armored car (8x8) 75mm Pak 40 [12]
247	schwerer geländegängiger gepanzerter Personenkraftwagen (4-Rad) « s. gl. gep. PKW »	heavy armored staff car (4x4) n/a
247	schwerer geländegängiger gepanzerter Personenkraftwagen (6-Rad) « s. gl. gep. PKW »	heavy armored staff car (6x4) n/a

## GERMAN SPECIAL MILITARY VEHICLES

Sd.Kfz. No.	German Designation « German Abbreviation »	Description Main Armament [Ammunition carried]
250 /1	leichter Schützenpanzerwagen « le. SPW »	light armored halftrack, personnel carrier MG [2010]
250 /1	leichter Schützenpanzerwagen « le. SPW »	light armored halftrack, heavy machine gun section carrier MG [2010]
250 /2	leichter Fernsprechpanzerwagen « le. Fe. Pzgw. »	light armored halftrack, telephone & wire carrier MG [1100]
250 /3	leichter Funkpanzerwagen « le. Fu. Pzgw. »	light armored halftrack, radio carrier MG [1100]
250 /4	leichter Beobachtungs-Panzerwagen « le. Beob. Pzgw. »	light armored halftrack, observation vehicle MG [1100]
250 /5	leichter Beobachtungspanzerwagen « le. Beob. Pzgw. »	light armored halftrack, observation vehicle MG [2010]
250 /5	leichter Aufklärungspanzerwagen « le. Beob. Pzgw. »	light armored halftrack, reconnaissance vehicle MG [2010]
250 /6	leichter Munitionspanzerwagen « le. Muni. Pzgw. »	light armored halftrack, ammunition carrier MG [1100] [transports 70 L/24 or 60 L/43 rounds]
250 /7(I)	leichter Schützenpanzerwagen (schwere Granatwerfer) « le. SPW (Gr Wfr) »	light armored halftrack, mortar carrier 81mm mortar [42]
250 /7(II)	leichter Schützenpanzerwagen (Munitionsfahrzeug) « le. SPW (Muni) »	light armored halftrack, 81mm mortar ammunition carrier MG [2010] [transports 66 mortar rounds]
250 /8	leichter Kanonenpanzerwagen (7,5cm) « le. SPW (2cm) »	light armored halftrack, support vehicle 75mm KwK 51 L/24 [20]
250 /9	leichter Schützenpanzerwagen (2cm) « le. SPW (2cm) »	light armored halftrack, reconnaissance vehicle 20mm KwK 38 [100]
250 /10	leichter Schützenpanzerwagen (3,7cm Pak) « le. SPW (3,7cm) »	light armored halftrack, Platoon Leader vehicle 37mm Pak L/45 [216]
250 /11	leichter Schützenpanzerwagen (schwere Panzerbüchse 41) « le. SPW (sPzBü 41) »	light armored halftrack, Platoon Leader vehicle 28mm PzBü 41 [168]
250 /11	leichter Messtrupp-Auswertungs-Panzerwagen « le. Mess-Trupp-Pzgw. »	light armored halftrack, Calibration Section vehicle MG [1040]
251 /1	mittlerer Schützenpanzerwagen « m. SPW »	medium armored halftrack, personnel carrier MG [2010]
251 /2	mittlerer Schützenpanzerwagen (Granatwerfer) « m. SPW (Gr Wfr) »	medium armored halftrack, mortar carrier 81mm mortar [66]
251 /3	mittlerer Funkpanzerwagen « m. Fu. Pzgw. »	medium armored halftrack, radio carrier MG [2010]
251 /4	mittlerer Schützenpanzerwagen (Infanteriegeschütz) « m. SPW (IG) »	medium armored halftrack, light IG prime-mover MG [1100] [transports 120 rounds of 75mm ammo]
251 /5	mittlerer Pionierpanzerwagen « m. Pion. Pzgw. »	medium armored halftrack, engineer vehicle MG [4800]
251 /6	mittlerer Kommandopanzerwagen « m. Pion. Pzgw. »	medium armored halftrack, command vehicle MG [1100]
251 /7	mittlerer Pionierpanzerwagen « m. Pion. Pzgw. »	medium armored halftrack, engineer vehicle MG [4800]
251 /8	mittlerer Krankenpanzerwagen « m. Kranken-Pzgw. »	medium armored halftrack, ambulance n/a
251 /9	mittlerer Schützenpanzerwagen (7,5cm) « m. SPW (7,5cm) »	medium armored halftrack, self-propelled light gun 75mm KwK 37 L/24 [32]
251 /10	mittlerer Schützenpanzerwagen (3,7cm Pak) « m. SPW (3,7cm) »	medium armored halftrack, Platoon Leader vehicle 37mm Pak L/45 [168]
251 /10	mittlerer Schützenpanzerwagen (sPzBü) « m. SPW (sPzBü) »	medium armored halftrack, Platoon Leader vehicle 28mm sPzBü 41 L/28/20 [168]
251 /11	mittlerer Fernsprech-Panzerwagen « m. SPW (Fe) »	medium armored halftrack, telephone cable-laying vehicle MG [1100]
251 /12	mittlerer Meßtrupp- und Gerät-Panzerwagen « m. Meßtrupp Pzgw. »	medium armored halftrack, Calibration Section equipment vehicle MG [1100]
251 /13	mittlerer Schallaufnahme-Panzerwagen « m. Schall-Aufnahme-Pzgw. »	medium armored halftrack, sound recording vehicle MG [1100]
251 /14	mittlerer Schallauswerte-Panzerwagen « m. Schall-Auswerte-Pzgw. »	medium armored halftrack, sound ranging vehicle MG [1100]

## GERMAN SPECIAL MILITARY VEHICLES

Sd.Kfz. No.	German Designation « German Abbreviation »	Description Main Armament [Ammunition carried]
251 /15	mittlerer Lichtauswerte-Panzerwagen « m. Licht-Auswerte-Pzwg. »	medium armored halftrack, sound flash ranging vehicle MG [1100]
251 /16	mittlerer Flamm-Panzerwagen « m. SPW (Flamm) »	medium armored halftrack, with 2 pivoted flame throwers 80 bursts of 2 – 3 seconds (700 liters flame oil); MG [2100]
251 /17	mittlerer Flak-Panzerwagen « m. SPW (2cm) »	medium armored halftrack, self-propelled light anti-aircraft gun 20mm Flak 38 [600]
251 /18	mittlerer Beobachtungs-Panzerwagen « m. Beob.-Pzwg. »	medium armored halftrack, observation vehicle MG [1100]
251 /19	mittlerer Fernsprech.Betriebs-Panzerwagen « m. Fs.Betr.-Pzwg. »	medium armored halftrack, telephone operations vehicle MG [1100]
251 /20(I)	mittlerer Panzerwagen (Uhu) « m. Pzwg. (Uhu) »	medium armored halftrack, infrared projector vehicle MG [1100]
251 /20(II)	mittlerer Panzerwagen (Falke) « m. Pzwg. (Falke) »	medium armored halftrack, infrared viewer vehicle MG [1100]
251 /21	mittlerer Panzerwagen (MG 151/15 Drilling) « m. SPW (MG 1,5cm) »	medium armored halftrack, self-propelled light anti-aircraft gun 15mm triple MG 151/15 [3000]
251 /21	mittlerer Panzerwagen (MG 151/20 Drilling) « m. SPW (MG 2cm) »	medium armored halftrack, self-propelled light anti-aircraft gun 20mm triple MG 151/20 [3000]
251 /22	mittlerer Panzerwagen (7,5cm Pak) « m. SPW (7,5cm Pak) »	medium armored halftrack, self-propelled anti-tank gun 75mm Pak 40 L/48 [22]
251 /23	mittlerer Panzerwagen (2cm Flak) « m. SPW (2cm Flak) »	medium armored halftrack, self-propelled light anti-aircraft gun 20mm KwK 38 L/55 [180]
252	leichter gepanzerter Munitionswagen « le. gep. Muni-Wg. »	light armored halftrack, ammunition carrier MG [1020]
253	leichter gepanzerter Beobachtungswagen « le. gep. Beob. Wg. »	light armored halftrack, observation vehicle MG [1100]
254	mittlerer gepanzerter Beobachtungswagen « m. gep. Beob. Wg. »	medium armored wheeled/tracked observation vehicle MG [1100]
260	kleiner Panzerfunkwagen « kl. Pz. Fu. Wg. »	light armored radio car (4x4) n/a
261	kleiner Panzerfunkwagen « kl. Pz. Fu. Wg. »	light armored radio car (4x4) n/a
263	schwerer Panzerfunkwagen « s. Pz. Fu. Wg. »	heavy armored radio car (6x4) MG [1020]
266	Panzerbefehlswagen « gr. Pz-Bef-Wg. »	command tank based on Pz-III, Pz-IV, Pz-V, or Pz-VI MG [1500]
267	Panzerbefehlswagen « gr. Pz-Bef-Wg. »	command tank based on Pz-III, Pz-IV, Pz-V, or Pz-VI MG [1500]
268	Panzerbefehlswagen « gr. Pz-Bef-Wg. »	command tank based on Pz-III, Pz-IV, Pz-V, or Pz-VI MG [1500]
300	Minenräumwagen B-I & B-II « Minenräum-Wg. »	tracked mineclearing vehicle, Model B-I & B-II n/a
301	schwere Ladungsträger B-IV « B-IV »	tracked, remote-controlled demolition vehicle, Model B-IV n/a
302	Leichte Ladungsträger Goliath, Ausf. A « Goliath »	tracked, remote-controlled demolition vehicle, Model A (electric) n/a
303	Leichte Ladungsträger Goliath, Auf. B « Goliath »	tracked, remote-controlled demolition vehicle, Model B (gasoline) n/a
304	mittlere Ladungsträger « Springer »	tracked, remote-controlled demolition vehicle n/a

### Notes:

For the sake of completeness, this list includes the unnumbered vehicles belonging to the same family of vehicles.

## GERMAN SPECIAL MILITARY TRAILERS AND MILITARY TRAILERS

### German Trailers

Besides the numbered trailers listed below, there were also trailers without numbers. These were identified by load factor, number of axles, open or covered, and/or purpose. Furthermore, upon mobilization, the German military requisitioned trailers from the civilian sector. These trailers were strictly for use by road-bound units, and only found in rear-echelon units where they provided a valuable increase in transportation capacity. There were even trailers built specifically for towing horse drawn equipment with motor vehicles.

A few military horse-drawn vehicles (wagons and carts) were modified for towing by motor vehicles by the addition of wheel and parking brakes, rubber-rimmed or even pneumatic tires, rear lights, and towing arrangements.

Some horse-drawn wagon and carts were issued with towing bars allowing them to be towed by motor vehicles.

It was not unusual, specially in the non-motorized units, that unmodified horse-drawn vehicles be towed by motor vehicles. Naturally at comparatively low speeds.

Although many combat units had trailers for guns, ammunition, components of heavy guns, generators, bridging equipment, etc., convoy speed of all vehicles was reduced when towing trailer, and maneuverability was hampered off-road. However, the expense of motor vehicles made the use of trailers an attractive alternative.

<i>Sd.Anh.-Sonder Anhänger</i>	<i>Special Trailers with numbers</i>
Sd.Anh. 1 (1 Achsig) für kleines Kettenkrad	trailer (1 axle) for Kettenkrad
Sd.Anh. 1/1 (1 Achsig) für kleines Kettenkrad	trailer (1 axle) for Kettenkrad
Sd.Anh. 1/2 (1 Achsig) für kleines Kettenkrad für schweres Feldkabel	trailer (1 axle) for Kettenkrad, with heavy telephone field cable.
Sd.Anh. 3 (1 Achsig) für leichte Lasten	trailer (1 axle) for transporting light artillery guns (7,5cm leFK 16 and 10,5cm leFH 16)
Sd.Anh. 4 (1 Achsig) für mittlere und schwere Lasten	trailer (1 axle) for transporting medium and heavy artillery guns (15cm sFH 13)
Sd.Anh. 5 (1 Achsig) für Artilleriemunition	trailer (1 axle) for artillery ammunition
Sd.Anh. 7 (1 Achsig) für Munition (Nbl. Wfr.)	trailer (1 axle) for Nebelwerfer ammunition
Sd.Anh. 8 (1 Achsig) für Veterinärgerät	trailer (1 axle) for veterinary equipment
Sd.Anh. 11 (1 Achsig) für Entseuchung mit Brausevorrichtung	trailer (1 axle) for decontamination with showers
Sd.Anh. 13 (1 Achsig) für M-Boot (100 PS MB 41)	trailer (1 axle) for motorboat (100 HP Type MB 41)
Sd.Anh. 14 (1 Achsig) für Abschleppzwecke	trailer (1 axle) for motor vehicle towing and recovery
Sd.Anh. 15 (1 Achsig) für Fährseil	trailer (1 axle) for winch
Sd.Anh. 20 (1 Achsig) für Erdkabel	trailer (1 axle) for underground telephone cable
Sd.Anh. 21 (2 Achsig) für Fernsprechbau	trailer (1 axle) for telephone construction
Sd.Anh. 22 (1 Achsig) Azetylen-Erzeugeranhängen	trailer (1 axle) for generator for Acetylene gas
Sd.Anh. 23 (1 Achsig) für Sammlerladegerät D	trailer (1 axle) for Generator Type D for recharging batteries
Sd.Anh. 23/1 (1 Achsig) für Maschinensatz 220/65V; 4,5/1,3 Kw	trailer (1 axle) for Generator 220/65 Volt, 4.5/1.3 Kw
Sd.Anh. 24 (1 Achsig) für Maschinensatz I	trailer (1 axle) for Generator Type I
Sd.Anh. 24 (1 Achsig) für Maschinensatz A (Drehstrom 15k VA)	trailer (1 axle) for Generator Type A for 15k AC
Sd.Anh. 25 (1 Achsig) für Feldfernkabel	trailer (1 axle) for heavy telephone field cable
Sd.Anh. 25/1 (1 Achsig) für Maschinensatz F	trailer (1 axle) for Generator Type F
Sd.Anh. 25/2 (1 Achsig) für Nachrichtengerät	trailer (1 axle) for signal equipment
Sd.Anh. 25/3 (1 Achsig) Beleuchtungsanhänger N	trailer (1 axle) for Lighting Equipment Type N
Sd.Anh. 25/4 (1 Achsig) Nachschubanhänger	trailer (1 axle) for supply
Sd.Anh. 25/3 (1 Achsig) Beleuchtungsanhänger N	trailer (1 axle) for lighting equipment
Sd.Anh. 26 (1 Achsig) für Führungsfernkabel	trailer (1 axle) for command telephone heavy cable
Sd.Anh. 28 (1 Achsig) für Peilanhänger (für Peiltrupp (LMW)	trailer (1 axle) for direction finder of a Direction Finding Section
Sd.Anh. 29 (1 Achsig) für für gepanzerten Munitionsschlepper	trailer (1 axle) for ammunition (for armored ammunition carrier)
Sd.Anh. 30 (1 Achsig) Wassertankanhänger	trailer (1 axle) for water tank
Sd.Anh. 31 (1 Achsig) für Munition Type A	trailer (1 axle) for ammunition Type A
Sd.Anh. 31/1 (1 Achsig) für Munition (7,5cm StuK 40)	trailer (1 axle) for ammunition for 7.5cm Assault Gun Model 40
Sd.Anh. 32 (1 Achsig) für Munition (3,7cm Pak)	trailer (1 axle) for ammunition for 3,7cm Antitank Gun
Sd.Anh. 32/1 (1 Achsig) für Munition (7,5cm)	trailer (1 axle) for ammunition for 7,5cm
Sd.Anh. 32/2 (1 Achsig) für Munition (s. Pz Bü 41)	trailer (1 axle) for ammunition for heavy antitank rifle Model 41
Sd.Anh. 32/3 (1 Achsig) für s. Pz Bü 41 auf leichte Feldlafette	trailer (1 axle) for heavy antitank rifle Model 41 on light field carriage
Sd.Anh. 33 (1 Achsig) für Nebelwerfermunition	trailer (1 axle) for ammunition (rocket launcher)
Sd.Anh. 34 (1 Achsig) für Entgiftungsanhänger	trailer (1 axle) for decontamination
Sd.Anh. 35 (1 Achsig) für Teigknetanhänger	trailer (1 axle) for dough mixer
Sd.Anh. 36 (1 Achsig) für leichten Ladungsschlepper	trailer (1 axle) for remote control vehicle (Goliath)
Sd.Anh. 40 (1 Achsig) Panzerbergeanker als Anhänger	trailer (1 axle) for tank recovery anchor
Sd.Anh. 46 (1 Achsig) schmalspurig	trailer (1 axle) with narrow wheel spacing
Sd.Anh. 51 (1 Achsig) Beleuchtungsanhänger (Vermessungstrupp (mot)	trailer (1 axle) for electricity generator in enclosed body for Calibration Detachment
Sd.Anh. 51 (1 Achsig) für 2cm Geschütz 30 mit Munition- und Zubehörkasten	trailer (1 axle) for 2cm antiaircraft gun Model 30 with ammo and equipment boxes
Sd.Anh. 51 (1 Achsig) für Scheinwerfer 60cm mit Zubehörkasten	trailer (1 axle) for 60cm antiaircraft searchlight with equipment boxes
Sd.Anh. 51 (1 Achsig) für 2cm Flak 38 mit Munition- und Zubehörkasten	trailer (1 axle) for 20mm antiaircraft gun Model 38 with ammo and equipment boxes
Sd.Anh. 52 (1 Achsig) für 2cm Flak Vierling 38/1 mit Munition- und Zubehörkasten	trailer (1 axle) for 2cm quad antiaircraft gun Model 38/1 with ammo and equipment boxes
Sd.Anh. 52 (1 Achsig) für 3,7cm Flak 36/37 mit Munition- und Zubehörkasten	trailer (1 axle) for 3.7cm antiaircraft gun Model 36/37 with ammo and equipment boxes
Sd.Anh. 52 (1 Achsig) für Kommando-Gerät 40	trailer (1 axle) for antiaircraft fire direction computer Model 40
Sd.Anh. 53 (1 Achsig) für Kommando-Hilfsgerät 35	trailer (1 axle) for antiaircraft auxiliary fire direction computer Model 35
Sd.Anh. 54 (1 Achsig) für Kinotheodolit für Flakmess-Auswerte-Zug	trailer (1 axle) for antiaircraft optical tracking computer for Calibration Evaluation Platoon
Sd.Anh. 55 (1 Achsig) für V <sup>o</sup> -Messgerät Flak	trailer (1 axle) for antiaircraft muzzle velocity calibration equipment
Sd.Anh. 56 (1 Achsig) für 2cm Flak mit Munition- und Zubehörkasten	trailer (1 axle) for 2cm quad antiaircraft gun with ammo and equipment boxes
Sd.Anh. 56 (1 Achsig) für 2cm Flakvierling 38/1 mit Munition- und Zubehörkasten	trailer (1 axle) for 2cm quad antiaircraft gun Model 38/1 with ammo and equipment boxes
Sd.Anh. 57 (1 Achsig) für 3,7cm Flak mit Munition- und Zubehörkasten	trailer (1 axle) for 3.7cm antiaircraft gun with ammo and equipment boxes
Sd.Anh. 58 (1 Achsig) für 3,7cm Flak 43 mit Munition- und Zubehörkasten	trailer (1 axle) for 3.7cm antiaircraft gun Model 43 with ammo and equipment boxes
Sd.Anh. 58 (1 Achsig) für 3,7cm Flak 43/1 mit Munition- und Zubehörkasten	trailer (1 axle) for 3.7cm antiaircraft gun Model 43/1 with ammo and equipment boxes
Sd.Anh. 101 (2 Achsig) für Flakhorchgerät	trailer (2 axle) for antiaircraft sound tracking equipment
Sd.Anh. 101 (2 Achsig) für mittleren Flak-Maschinensatz	trailer (2 axle) for antiaircraft generator for sound tracking equipment
Sd.Anh. 102 (2 Achsig) für Flak-Scheinwerfer 110cm	trailer (2 axle) for antiaircraft searchlight (110cm)
Sd.Anh. 102 (2 Achsig) für Flak-Maschinensatz	trailer (2 axle) for antiaircraft generator for searchlight (110cm)
Sd.Anh. 103 (2 Achsig) für mittlere und schwere Lasten	trailer (2 axle) for medium and heavy cargo
Sd.Anh. 104 (2 Achsig) für 150cm Flak-Scheinwerfer	trailer (2 axle) for 150cm antiaircraft searchlight
Sd.Anh. 104 (2 Achsig) für Maschinensatz 24 Kw für 150cm Flak-Scheinwerfer	trailer (2 axle) for generator Model 24Kw for 150cm antiaircraft searchlight
Sd.Anh. 104 (2 Achsig) für Sperrballonwinde	trailer (2 axle) for winch for antiaircraft barrage ballon
Sd.Anh. 104 (2 Achsig) für Funkmessgerät 39 TD	trailer (2 axle) for antiaircraft radar Model 39TD
Sd.Anh. 104 (2 Achsig) für 3,7cm Flak 18	trailer (2 axle) for 3.7cm antiaircraft gun Model 18
Sd.Anh. 104 (2 Achsig) für Kommandogerät 36	trailer (2 axle) for antiaircraft fire direction computer Model 36
Sd.Anh. 104 (2 Achsig) für Richtung-Richtungshörer (RRH)	trailer (2 axle) for antiaircraft sound tracking equipment
Sd.Anh. 105 (2 Achsig) Backanhänger	trailer (2 axle) for baking oven
Sd.Anh. 106 (2 Achsig) Backanhänger	trailer (2 axle) for baking oven
Sd.Anh. 107 (2 Achsig) Grosskühlbehälteranhänger	trailer (2 axle) for refrigeration
Sd.Anh. 108 (2 Achsig) für S-Boot (Pionier-Strumboot 39)	trailer (2 axle) for three assault boats (Engineer Assault Boat Model 39)

## GERMAN SPECIAL MILITARY TRAILERS AND MILITARY TRAILERS

Sd.Anh. 109	(2 Achsig) leichter Vermessungsanhänger .....	trailer (2 axle) for light calibration equipment
Sd.Anh. 111	(2 Achsig) schwerer Vermessungsanhänger .....	trailer (2 axle) for heavy calibration equipment
Sd.Anh. 113	(3 Achsig) für Langerät (8 ton) .....	trailer (3 axle) for cargo, long (8ton)
Sd.Anh. 115	Tiefhladeanhänger für PzKfpWg 10-12 ton .....	trailer (2 axle) low boy (also: low bed) for armored vehicles (10 – 12 ton)
Sd.Anh. 116	Tiefhladeanhänger für PzKfpWg 22 ton .....	trailer (4 axle) low boy (also: low bed) for armored vehicles (22 ton)
Sd.Anh. 119	(2 Achsig) für 100 PS-Motorboot .....	trailer (2 axle) for motorboat (100 HP Type MB 41)
Sd.Anh. 120	(2 Achsig) für 250 PS-Motorboot .....	trailer (2 axle) for motorboat (250 HP Type MB 42)
Sd.Anh. 121	Tiefhladeanhänger für PzKfpWg 65 ton .....	trailer (6 axle) low boy (also: low bed) for armored vehicles (65 ton)
Sd.Anh. 127	(2 Achsig) Mastanhänger .....	trailer (2 axle) for mast antenna
Sd.Anh. 141	(2 Achsig) für Pionier-Landungs-Fahrzeug 20-ton .....	trailer (2 axle) for engineer landing vehicle (20ton)
Sd.Anh. 201	(2 Achsig) für 8,8cm Flak .....	trailer (2 axle) for 8.8cm antiaircraft gun
Sd.Anh. 202	(2 Achsig) für 8,8cm Flak 37/37 .....	trailer (2 axle) for 8.8cm antiaircraft gun Model 36/38
Sd.Anh. 202	(2 Achsig) für 8,8cm Flak 41 .....	trailer (2 axle) for 8.8cm antiaircraft gun Model 41
Sd.Anh. 203	(2 Achsig) für 10,5cm Flak 38/39 .....	trailer (2 axle) for 10.5cm antiaircraft gun Model 38/39
Sd.Anh. 203	(2 Achsig) für Fahrgerüst für schwere 12,8cm Flak (o) .....	trailer (2 axle) for mobilizing the static, heavy 12.8cm antiaircraft gun
Sd.Anh. 203	(2 Achsig) Transportbrücke für 12,8cm Flak-Zwilling .....	trailer (2 axle) for 12.8cm twin antiaircraft gun
Sd.Anh. 204	(2 Achsig) für 5cm Flak 41 .....	trailer (2 axle) for 5cm antiaircraft gun Model 41
Sd.Anh. 204	(2 Achsig) für 200cm Flak-Scheinwerfer .....	trailer (2 axle) for 200cm antiaircraft searchlight
Sd.Anh. 204	(2 Achsig) für Maschinensatz für 200cm Flak-Scheinwerfer .....	trailer (2 axle) for generator for 200cm antiaircraft searchlight
Sd.Anh. 204	(2 Achsig) für Maschinensatz 60 kW .....	trailer (2 axle) for generator Model 60Kw
Sd.Anh. 204	(2 Achsig) für Sperrballonwinde .....	trailer (2 axle) for winch for barrage balloon
Sd.Anh. 205	(2 Achsig) Rohrwagen für 10,5cm Flak .....	trailer (2 axle) for barrel wagon for 10.5cm antiaircraft gun
Sd.Anh. 206	(2 Achsig) für 5,5cm Flak 58 .....	trailer (2 axle) for 5.5cm antiaircraft gun Model 58
Sd.Anh. 206	(2 Achsig) für 3,7cm Flak-Zwilling 43 .....	trailer (2 axle) for 3.7cm dual antiaircraft gun Model 43
Sd.Anh. 206	(2 Achsig) für 200cm Flak-Scheinwerfer 44 .....	trailer (2 axle) for 200cm antiaircraft searchlight Model 44
Sd.Anh. 206	(2 Achsig) für Maschinensatz 120 kW .....	trailer (2 axle) for generator Model 120Kw
Sd.Anh. 206	(2 Achsig) für Funkmessgerät .....	trailer (2 axle) for antiaircraft radar
Sd.Anh. 206	(2 Achsig) für Flakrakete H3 117 "Schmetterling" .....	trailer (2 axle) for antiaircraft rocket Model Hs 117 "Schmetterling" (Butterfly)
Sd.Anh. 220	(4 Achsig) für Funkmessgerät .....	trailer (4 axle) for radar system
Sd.Anh. 220	(4 Achsig) für 12,8cm Flak 40/1 .....	trailer (4 axle) for 12.8cm antiaircraft gun Model 40/1
Sd.Anh. 301	(1 Achsig) für Tankspritze .....	trailer (1 axle) for fire engine equipment (auxiliary for the fire engine)
Sd.Anh. 302	(1 Achsig) für Schlauchtender .....	trailer (1 axle) for mobile fire fighting (for independent operation)
Sd.Anh. 319	für Fla-Rakete "Wasserfall" .....	trailer for antiaircraft rocket "Wasserfall" (Waterfall)
Sd.Anh. 322	für A2 (o) 7,5-ton mit geschlossenem Aufbau .....	trailer for rocket A2 (o) with enclosed body (7.5 ton)
Sd.Anh. 322/2	für Landescheinwerfer (Gl 1500) .....	trailer for 1500cm landing searchlight Model Gl 1500
Sd.Anh. 322/3	für Landescheinwerfer (HgLL 1500) .....	trailer for 1500cm landing searchlight Model Hg LL 150
Sd.Anh. 350	für B2 (3-ton) (o) mit geschlossenem Aufbau .....	trailer B2 with enclosed body (civilian type)(3-ton)
Sd.Anh. 350/7	Fernsprechvermittlungs-Anhänger .....	telephone exchange trailer
Sd.Anh. 350/32	Leuchfeueranhänger .....	generator trailer for airfield beacons
Sd.Anh. 350/33	Leuchfeueranhänger .....	generator trailer for airfield beacons
Sd.Anh. 350/32	Prüf- und Wartungs-Anhänger für Bordfunk- und Peilgerät .....	trailer for maintenance and testing of aircraft radio and radar equipment
Sd.Anh. 350/43	Prüf- und Wartungs-Anhänger für Bordfunk- und Peilgerät .....	trailer for maintenance and testing of aircraft radio and radar equipment
Sd.Anh. 350/?	Anhänger B2 für Ladestation FR .....	trailer B2 with enclosed body (civilian type)(3-ton) for battery charger for V2 rocket units
Sd.Anh. 363	für B3 (4,5-ton) (o) mit geschlossenem Aufbau .....	trailer B3 with enclosed body (civilian type)(4.5-ton)
Sd.Anh. 363/1	für B3 (4,5-ton) (o) für Bildbearbeitung .....	trailer B3 with enclosed body (civilian type)(4.5-ton) for photograph production Type I
Sd.Anh. 363/2	für B3 (4,5-ton) (o) für Bildbearbeitung .....	trailer B3 with enclosed body (civilian type)(4.5-ton) for photograph production Type II
Sd.Anh. 401	(1 Achsig) Feldküche als Anhänger .....	trailer (1 axle) mobile field kitchen ("Gulaschkanone")
Sd.Anh. 422	(1 Achsig) Navigations-Funkpeilanhänger .....	trailer (1 axle) for direction finding equipment for navigation
Sd.Anh. 447	(2 Achsig) Navigations-Funkpeilanhänger .....	trailer (2 axle) for direction finding equipment for navigation
Sd.Anh. 450	(2 Achsig) Tragflächen 6 Meter .....	trailer (2 axle) for transporting wings (6 meters)
Sd.Anh. 451	(2 Achsig) Tragflächen 10 Meter .....	trailer (2 axle) for transporting wings (10 meters)
Sd.Anh. 450	(2 Achsig) Tragflächen 6 Meter .....	trailer (2 axle) for wings (6 meters)
Sd.Anh. 454	(2 Achsig) Flugbetriebsstoffkessel-Anhänger .....	trailer (2 axle) bowser for aircraft fuel
Sd.Anh. 458	(2 Achsig) Waffenabwurfgerät-Anhänger .....	trailer (2 axle) for bomb transport
Sd.Anh. 459	(2 Achsig) Waffenabwurfgerät-Anhänger .....	trailer (2 axle) for bomb transport
Sd.Anh. 469	(2 Achsig) Fernschreib-Anschlussanhänger .....	trailer (2 axle) with enclosed body for telephone switchboard
Sd.Anh. 470	(2 Achsig) Funkanhänger (Kurz- /Langwelle) .....	trailer (2 axle) with enclosed body for short and medium wave radio station
Sd.Anh. 471	(2 Achsig) Betriebs-Funkempfängeranhänger .....	trailer (2 axle) with enclosed body for radio receiver operation station
Sd.Anh. 472	(2 Achsig) leichter Leuchfeueranhänger .....	trailer (2 axle) with enclosed body light generator for airfield beacons
Sd.Anh. 473	(2 Achsig) mittlerer Leuchfeueranhänger .....	trailer (2 axle) with enclosed body medium generator for airfield beacons
<b>Vsah. = Versuchsanhänger</b> .....	<b>Experimental Trailers</b>	
Vsah. 642	Tiefhladeanhänger für Panzerkampfwagen .....	medium tank transport trailer
Vsah. 654	Tiefhladeanhänger für Panzerkampfwagen .....	light tank transport trailer
<b>Anhänger</b> .....	<b>Trailers without numbers</b>	
(1 Achsig) Anhänger-Fahrgestell 900 kg .....	trailer (1 axle) chassis (900 kilos)	
(1 Achsig) Anhänger-Fahrgestell 1500 kg Baumuster 41 .....	trailer (1500 axle) chassis Model 41 (1500 kilos)	
(1 Achsig) Anhänger-Fahrgestell 1900 kg .....	trailer (1 axle) chassis (1900 kilos)	
(1 Achsig) Anhänger-Fahrgestell gl. 500 kg .....	trailer (1 axle) chassis cross-country capable (500 kilos)	
(1 Achsig) Anhänger-Fahrgestell gl. 900 kg .....	trailer (1 axle) chassis cross-country capable (900 kilos)	
(1 Achsig) Anhänger-Fahrgestell gl. 1500 kg .....	trailer (1 axle) chassis cross-country capable (1500 kilos)	
(1 Achsig) Anhänger-Fahrgestell gl. 2200 kg .....	trailer (1 axle) chassis cross-country capable (2200 kilos)	
(1 Achsig) Anhänger A1 (0,5 t), offen (o) .....	trailer (1 axle) Model A1, civilian type, open (500 kilos)	
(1 Achsig) Anhänger A1 (0,5 t), offen (o) als Schlauchhaspel für Kfz. 346 .....	trailer (1 axle) Model A1, civilian type, open (500 kilos), for hoses, towed by Kfz. 346	
(1 Achsig) Anhänger mit geschlossenem Aufbau (o) für Eisenbahn-Pionier .....	trailer (1 axle) civilian type, enclosed, for Railroad Engineers	
(1 Achsig) Anhänger mit geschlossenem Aufbau (o) für Kraftfahrzeug-Parkes .....	trailer (1 axle) civilian type, enclosed, for Motor Vehicle Parks	
(1 Achsig) Anhänger gl. für Einheitsbehälter für Kraftstoff .....	trailer (1 axle) cross-country capable, for standard fuel cans ("Jerry cans")	
(1 Achsig) Anhänger für 200-Liter Kraftstoff-Fass .....	trailer (1 axle) fuel barrel (200 liters)	
(1 Achsig) Anhänger für 2x 200-Liter Kraftstoff-Fass .....	trailer (1 axle) 2 fuel barrels (each 200 liters)	
(1 Achsig) Anhänger für Ladungswerfer .....	trailer (1 axle) for heavy spigot mortar of the engineers	
(1 Achsig) Anhänger für M.S. Boot (handelsüblichen Gerät) der Pioniere .....	trailer (1 axle) for civilian motor boat used by the engineers	
(1 Achsig) Anhänger mit Notstromaggregat 12kVA "Carfais" Diesel der Marine .....	trailer (1 axle) for diesel power generator "Carfais" for the Navy	
(1 Achsig) Anhänger mit Notstromaggregat 12kVA "Fimag" Bezin der Marine .....	trailer (1 axle) for gasoline power generator "Fimag" for the Navy	
(1 Achsig) Anhänger für schwere Panzerbüchse 41 .....	trailer (1 axle) for heavy antitank rifle (PzBü 41)	



## GERMAN SPECIAL MILITARY TRAILERS AND MILITARY TRAILERS

(1 Achsig) Anhänger für Rudegaszellen .....	trailer (1 axle) for gas bottles (gas used against mangle)
(1 Achsig) Anhänger fur Verschluss-Sachen der Vermessungs- und Karten-Einheiten .....	trailer (1 axle) enclosed, lockable, for confidential material of the surveying and mapping units
(1 Achsig) Anhänger offen (o) fur Veterinargerat fur Pferdellazarett .....	trailer (1 axle) civilian type, open, for veterinary equipment for veterinary hospital
(1 Achsig) Anhänger fur V2.Abschussplattform .....	trailer (1 axle) for firing platform for V2 rocket units
(1 Achsig) Diesel-Eisbereiter als Anhanger .....	trailer (1 axle) for diesel powered ice maker
(1 Achsig) Brennschluss-Antennen-Anhanger fur schiess Fernraketen-Batterien .....	trailer (1 axle) for antenna for establishing rocket-cut-off for V2 rocket units
(1 Achsig) Grosser Druckluftzeuger als Anhanger .....	trailer (1 axle) with large air compressor
(1 Achsig) Fallschirmjagerkarren als Anhanger fur das Kettenkrad .....	cart (1 axle) for Kettenkrad for Fallschirmjager (Parachute Infantry)
(1 Achsig) Grosse Feldkuche als Anhanger .....	trailer (1 axle) for mobile large field kitchen range
(1 Achsig) Festungskabeltottkarren .....	cart (1 axle) for Fortress Signal Troops, with sodering and other equipment
(1 Achsig) Festungskabelmesskarren .....	cart (1 axle) for Fortress Signal Troops, with calibration and other equipment
(1 Achsig) schweren Grabenpflug (Entgiftungspflug) als Anhanger .....	trailer (1 axle) heavy plow, originally for decontamination, but also used for entrenching
(1 Achsig) Handkarren fur leichten Ladungswerfer der Pioniere .....	hand cart (1 axle) for light spigot mortar of the engineers
(1 Achsig) kleiner Kabeltrommel-Anhanger fur Fernraketen-Einheit .....	trailer (1 axle) for light cable drums for V2 rocket units
(1 Achsig) Leitstrahl-Antennen-Anhanger fur FR-Einheit .....	trailer (1 axle) for guiding beam antenna for V2 rocket units
(1 Achsig) Leitstrahl-Kontroll-Anhanger fur FR-Einheit .....	trailer (1 axle) for guiding beam instrumentation for V2 rocket units
(1 Achsig) Lichtbogen-Schweissmaschinensatz auf Anhangerfahrgestell 1500 t .....	trailer (1 axle) arch welding equipment on chassis Model 41 (1500 kilos)
(1 Achsig) Maschinensatz 110/220 V 24 Kw als Anhanger fahrbar .....	trailer (1 axle) generator (110/220 Volts, 24 kW)
(1 Achsig) Maschinensatz 220 V 6,5 Kw als Anhanger fahrbar .....	trailer (1 axle) generator (220 Volts, 6.5 kW)
(1 Achsig) Maschinensatz 220 V (Wechselstrom) 15/18 KVA der Sanitatstruppe .....	trailer (1 axle) generator (220 Volts, AC, 15 kVA) for the Medical Troops
(1 Achsig) Maschinensatz 220/380 (Drehstrom) 30 Kw als Anhanger fahrbar .....	trailer (1 axle) generator (220/380 Volts, DC, 30 kVA)
(1 Achsig) Motorspritze als Anhanger fahrbar (o) .....	trailer (1 axle) motor water pump (civilian type)
(1 Achsig) Anhanger leichter Spruhanhanger .....	trailer (1 axle) light decontamination spray unit
(1 Achsig) Tragkraftspritzen-Anhanger (Tsga 8)(Bauart 1937) .....	trailer (1 axle) fire fighting equipment, including a portable water pump Type Tsga 8/37
(1 Achsig) Tragkraftspritzen-Anhanger (Tsga 8)(Bauart 1939) .....	trailer (1 axle) fire fighting equipment, including a portable water pump Type Tsga 8/39
(1 Achsig) Tragkraftspritzen-Anhanger (o) .....	trailer (1 axle) fire fighting equipment, civilian type, including a portable water pump
(1 Achsig) Troganhanger furEntgiftungskraftwagen (Kfz. 305/112) des S.H.D. ....	trailer (1 axle) for decontamination van of the S.H.D. ("Sicherheits- und Hilfedienst")
(1 Achsig) T-Stoff-Vorwarmer-Anhanger fur FR-Einheit .....	trailer (1 axle) for warming fuel (T-Staff = Hydrogensuperoxyd) for the V2 rocket units
(1 Achsig) Wasser-Anhanger 100 liter .....	trailer (1 axle) bowser for water (1000 liters)
(2 Achsig) Anhanger A2 Einheits-Anhanger 1 t offen (o) .....	trailer (2 axle) Standard Model A2, civilian type, open (1 ton)
(2 Achsig) Anhanger A2 als Schlauchhaspel fur Schlauchkraftwagen (Kfz. 346) .....	trailer (2 axle) Standard Model A2, civilian type, open (1 ton), for hoses, towed by Kfz. 346
(2 Achsig) Anhanger B2 Einheits-Anhanger 3 t offen (o) .....	trailer (2 axle) Standard Model B2, civilian type, open (3 ton)
(2 Achsig) Anhanger B2 mit Maschinensatz 220/380 V Drehstrom 60 KVA .....	trailer (2 axle) Standard Model B2, for generator (220/380 Volts, DC, 60 kVA)
(2 Achsig) Anhanger B3 Einheits-Anhanger 4,5 t offen (o) .....	trailer (2 axle) Standard Model B3, civilian type, open (4.5 ton)
(2 Achsig) Anhanger E5 Einheits-Anhanger 5 t offen (o) .....	trailer (2 axle) Standard Model E5, civilian type, open, (5 ton)
(2 Achsig) Anhanger E8 Einheits-Anhanger 8 t offen (o) .....	trailer (2 axle) Standard Model E8, civilian type, open, (8 ton)
(2 Achsig) Anhanger mit Anlage zum Nachfullen des Sauerstoffbedarf von Kampfflugzeuge .....	trailer (2 axle) for filling Oxygen into fighter planes
(2 Achsig) Anhanger (Langholz) fur 6 Auffahrtsschienen Bruckengerat 1.Z. ....	trailer (2 axle) for 6 ramps of Type 1.Z. bridge (long pole equipment)
(2 Achsig) Anhanger mit mittlerer Betriebsstoffkesselanlage (o) der Luftwaffe .....	trailer (2 axle) with medium boiler tank for aviation fuel
(2 Achsig) Anhanger mit schwererBetriebsstoffkesselanlage (o) der Luftwaffe .....	trailer (2 axle) with heavy boiler tank for aviation fuel
(2 Achsig) Anhanger mit Feldballonwinde 40 der Artillerie .....	trailer (2 axle) with winch for observation ballon Model 40 of the artillery
(2 Achsig) Anhanger mit Flakkommandogerat Hazemeyer der Marine .....	trailer (2 axle) with antiaircraft fire direction computer Model Hazemeyer
(2 Achsig) Anhanger mit 2cm-Flak auf Socketlafette .....	trailer (2 axle) for 2 cm antiaircraft gun Model 30 on pedestal base
(2 Achsig) Anhanger mit Kessel fur Flusssigsauerstoff fur Fernraketen .....	trailer (2 axle) with tank for Liquid Oxygen for V2 rocket units
(2 Achsig) Anhanger mit Kurbelmast 30m der Nachrichtentruppen .....	trailer (2 axle) with extendable antenna (30 meters) for the Signal Troops
(2 Achsig) Anhanger 1,5 t fur Raupenschlepper Ost .....	trailer (2 axle) for Raupenschlepper Ost (1.5 ton)
(2 Achsig) Anhanger fur Schleppboot 200 PS der Pioniere .....	trailer (2 axle) for towing boat (200 HP) of the Engineers
(2 Achsig) Anhanger schwimmfahig fur Land-Wasser-Schlepper (Kassbohrer) .....	trailer (2 axle) for the amphibious truck ("LWS")(made by Kassbohrer)
(2 Achsig) Entgiftungsgerate-Anhanger fur den Entgiftungsgeratekw. (Kfz. 305/12) .....	trailer (2 axle) for the decontamination equipment truck (Kfz. 305/12)
(2 Achsig) Kabeltrommel-Anhanger fur FR-Einheiten .....	trailer (2 axle) for cable drums for V2 rocket units
(2 Achsig) Kfz. Werkstatt-Kessel fur FR-Einheiten .....	trailer (2 axle) with motor maintenance shop for V2 rocket units
(2 Achsig) Landebahn-Leuchtanhanger .....	trailer (2 axle) for runway lighting
(2 Achsig) Luftverdichter-Anhanger fur FR-Einheiten .....	trailer (2 axle) for air compressor for V2 rockets
(2 Achsig) Omnibus-Anhanger (Kassebohrer Type P4 1939) .....	trailer (2 axle) for motor bus (bus Model P4 1939)(made by Kassebohrer)
(2 Achsig) Rohrwagen 40 fur 12,8cm Flak 40 .....	trailer (2 axle) for 12,8cm antiaircraft gun barrel
(2 Achsig) Sagevollgater auf Anhanger .....	trailer (2 axle) for mobile buzzsaw
(2 Achsig) Scheinwerfer-Transportwagen fur Scheinwerfer G150 (alter Art) .....	trailer (2 axle) for 150cm searchlight Model G150 (old type)
(2 Achsig) Scheinwerfer-Transportwagen fur Scheinwerfer G110 .....	trailer (2 axle) for 110cm searchlight Model G110
(2 Achsig) Strabo-Kran 16t als Anhanger .....	trailer (2 axle) for 16 ton collapsible crane (made by Strabo)
(2 Achsig) Tragflachen-Transportanhanger a & b (Bauart 39) .....	trailer (2 axle) for transport of aircraft wings Type a and b, Model 39
(2 Achsig) V2 Transport-Anhanger Vidal .....	trailer (2 axle) for transporting a V2 rocket (made by Vidal)
(2 Achsig) Wasserstoffverdichter-Anhanger 41+42 .....	trailer (2 axle) for Hydrogen compression Model 41+42
(2 Achsig) Wasserstoffentwickler-Anhanger 40+41 .....	trailer (2 axle) for Hydrogen developing Model 40+41
(3 Achsig) Anhanger 8 t fur 800 PS Motorboot 43 .....	trailer (3 axle) (8 ton) for motor boat Model 53 (800 HP)
(3 Achsig) Anhanger offen (o) mit Nutzlast 11.000 kg .....	trailer (3 axle) cargo, civilian type, open (11 ton)
(3 Achsig) Anhanger mit 30-t Kran .....	trailer (3 axle) for 30-ton collapsible crane
(3 Achsig) Anhanger schwimmfahig mit Nutzlast von 10 t .....	trailer (3 axle) amphibious (10 ton)
(3 Achsig) Anhanger schwimmfahig mit Nutzlast von 20 t .....	trailer (3 axle) amphibious (20 ton)
(3 Achsig) Anhanger fur die Fernrakete A4 (V2) Fabrikat Meiller .....	trailer (3 axle) for transporting a V2 rocket (made by Meiller)
(4 Achsig) Anhanger fur schwere Lasten Culemeyer .....	trailer (4 axle) for heavy cargo (made by Culemeyer)
(6 Achsig) Anhanger fur schwere Lasten Culemeyer bis 60 t .....	trailer (6 axle) for heavy cargo (60 ton) (made by Culemeyer)
(6 Achsig) Anhanger fur schwere Lasten Gothaer Waggonfabrik bis 60 t .....	trailer (6 axle) for heavy cargo (60 ton) (made by Gothaer Waggonfabrik)
(Mehrachts) Anhanger fur schwere Lasten bis 110 t .....	trailer (multi-axle) for heavy cargo (110 ton)
(Mehrachts) Anhanger fur schwere Lasten bis 150 t .....	trailer (multi-axle) for heavy cargo (150 ton)
(Mehrachts) Anhanger mit geschlossenem Aufbau fur Zinkdruckrotationspresse .....	trailers (multi-axle) with enclosed body for zincograph rotating printing press

<b>Pf. = Pionierfahrzeuge .....</b>	<b>Engineer Vehicles</b>
Pf. 10 (2 Achsig) Bockwagen .....	trailer (2 axle) for bridge tressels
Pf. 11 (2 Achsig) Pontonwagen .....	trailer (2 axle) for bridge pontoons
Pf. 12 (2 Achsig) Rampenwagen .....	trailer (2 axle) for bridge ramps
Pf. 13 (1 Achsig) fur M-Boot (100 PS MB 41) .....	trailer (1 axle) for motorboat (100 HP Type MB 41)

### Note:

The designation of these four engineer trailers was a holdover from an earlier period; the old nomenclature was maintained, except that Pf. 13 is mentioned also as Sd.Anh. 13.

## GERMAN HORSE-DRAWN VEHICLES: WAGONS – CARTS — SLEDS

<b>Af</b>	= <b>Artilleriefahrzeuge</b> .....	<b>Artillerie Vehicles</b>
Af 3	Munitionswagen 96 n.A. ....	ammunition limber Type 96 n.A.
Af ?	Munitionshinterwagen 96 n.A. ....	ammunition rear limber Type 96 n.A.
Af 4	Feldhaubitzen-Munitionswagen .....	field howitzer ammunition wagon 98
Af 5	schwerer Munitionswagen 02 .....	heavy ammunition wagon 02
Af 7	Rohrwagen für 10cm K17 .....	barrel wagon – 10cm Gun (K17)
Af 8	Rohrwagen für 15cm K16 .....	barrel wagon – 15cm Gun (K16)
Af 12	Boebachtungswagen .....	artillery observation wagon
Af 14	Munitionswagen .....	ammunition wagon
Af 19	Rohrwagen für 10cm K18 oder sFH 18 .....	barrel wagon – 10cm Gun or 15cm sFH
Af ?	Feldhaubitze .....	limber for field howitzer
Af ?	Munitionshunterwagen 98 .....	ammunition rear limber Type 98
Af ?	Munitionswagen 38 für 7,5cm Feldkanone 38 .....	ammunition limber for 7,5cm field gun
Af ?	Feldkanonenprotze für 7,5cm Feldkanone 38 .....	limber for 7,5cm field gun 38
Af ?	leichte Feldhaubitze 98E .....	limber for light field howitzer 98E
Af ?	leichte Feldhaubitze 18 .....	limber for light field howitzer 18
Af ?	leichte Feldhaubitze 18/40 .....	limber for light field howitzer 18/40
Af ?	schwerer Feldhaubitzen-Munitionswagen .....	heavy field howitzer ammunition wagon

<b>EF</b>	= <b>Ersatzfeldwagen</b> .....	<b>Replacement Field Wagon</b>
EF40	Wirtschaftswagen .....	supply wagon

<b>Hf</b>	= <b>Heeresfahrzeug</b> .....	<b>Army Vehicles</b>
Hf 1	leichter Feldwagen (gefedert) .....	light field wagon (sprung)
used as	Verpflegungswagen .....	rations wagon
	Sanitätsträgerwagen .....	stretcher bearer wagon
	Packwagen .....	baggage wagon
	Veterinärmitelwagen .....	veterinary equipment wagon
	Schanzzeugwagen .....	entrenching equipment wagon
Hf 1/1	grosser Gefechtswagen .....	large combat wagon
used as	Nachrichtengerätswagen (gefedert) .....	signal equipment wagon (sprung)
	Pioniergerätswagen (gefedert) .....	engineer equipment wagon (sprung)
	Vermessungsgerätswagen (gefedert) .....	survey equipment wagon (sprung)
Hf 1/2	Handscheinwerferwagen (M) .....	hand held searchlight wagon
Hf 1/3	Handscheinwerferwagen (S)(gefedert) .....	hand held searchlight wagon (sprung)
Hf 1/4	Beobachtungs-Gerätswagen .....	observation equipment wagon
Hf 1/11	grosser Gefechtswagen .....	large combat wagon
used as	Nachrichtengerätswagen .....	signal equipment wagon
Hf 1/13	grosser Fahnschmiedwagen .....	large farrier wagon
Hf 1/14	Packwagen für Feldschmiede .....	field forge wagon
Hf 1/14	Waffenmeisterwagen .....	armorer wagon
Hf 1/16	Bäckereigerät-Wagen .....	bakery equipment wagon
Hf 1/18	Truppensanitäts-Wagen .....	medical equipment wagon
Hf 2	schwere Feldwagen .....	heavy field wagon
used as	Gerätswagen .....	equipment wagon
	schwerer Gefechtswagen .....	heavy combat wagon
	Lastwagen .....	cargo wagon
	Munitionswagen .....	ammunition wagon
	Packwagen .....	baggage wagon
	Verpflegungswagen .....	rations wagon
	Vorratswagen .....	stores wagon
Hf 3	kleiner Feldwagen .....	small field wagon (600 kilo)
Hf 3/1	Nachrichtengerätswagen (gefedert) .....	signal wagon (sprung)
Hf 3/2	leichter Frenspchswagen (gefedert) .....	ligh telephone wagon (sprung)
Hf 3/11	kleiner Gefechtswagen .....	small combat wagon
Hf 3/12	kleiner Fahnschmiedwagen .....	small farrier wagon
Hf 4	Gebirgskarren .....	mountain cart
Hf 7	Stahlfeldwagen (gefedert) .....	field wagon (steel)(sprung)
Hf 7/11	grosser Gefechtswagen (Stahlfeldwagen) .....	large combat wagon (steel)
Hf 7/13	grosser Fahnschmiedwagen (Stahlfeldwagen) .....	large farrier wagon (steel)
Hf 7/14	Waffenmeisterwagen (Stahlfeldwagen) .....	armorer wagon (steel)
Hf 8	Bockwagen .....	tressel transport wagon
Hf 9	Pontonwagen .....	pontoon transport wagon
Hf 11	grosser Feldküche .....	large field kitchen
Hf 12	kleiner Feldküche .....	small field kitchen
Hf 13	grosser Feldküche .....	large field kitchen
Hf 14	kleiner Feldküche .....	small field kitchen
Hf ?	Munitionswagen .....	ammunition wagon
Hf ?	Vorratswagen .....	supply wagon
Hf ?	Sanitätswagen .....	medic wagon
Hf ?	Veterinärvorratswagen .....	veterinary supply wagon

## GERMAN HORSE-DRAWN VEHICLES: WAGONS – CARTS — SLEDS

<b>If</b>	<b>= Infanteriefahrzeuge</b>	<b>Infantry Vehicles</b>
If 3	Maschinengewehr-Wagen (s) (2 sMG)	heavy machine gun wagon (2 HMG)
If 4	Maschinengewehr-Wagen (1) (2 sMG)	light machine gun wagon (2 HMG)
If 4	Gebirgskarre	mountain cart
If 5	Maschinengewehrwagen (Zwillingssockel)	machine gun wagon (with pedestal for dual MG)
If 6	Gefechtskarre für s Gr.Wfr. /m. Gr.Wfr.	medium & heavy mortar wagon
If 7	Maschinengewehrwagen (1 sMG)	machine gun wagon (1 HMG)
If 7/24	Maschinengewehrwagen (MG7/24 Schwarzlose)	machine gun wagon (for HMG 7/24 Scharzloser)
If 8	Tornister-Funktrupp-Wagen	pack radio wagon
If 9	Gefechtskarre	combat cart
If 9/1	Gefechtskarre für 8cm Granatwerfer	combat cart for 8cm mortar
If 9/1	Munitionskarre für 8cm Granatwerfer	ammunition cart for 8cm mortar
If 12	Beobachtungswagen	observation wagon
If 12/1	leichte Infantriegeschützprotze	limber for light infantry gun
If 14	Munitionswagen	ammunition wagon
If 15	Beobachtungswagen	observation wagon
If ?	Gebirgskarre für 3,7cm Pak	mountain cart for 3,7cm antitank gun
If ?	Granatwerferkarre mit Rahmen M.24/25	mortar cart with frames

<b>Nf</b>	<b>= Nachrichtenfahrzeuge</b>	<b>Signal Vehicles</b>
Nf 1	schwerer Fernsprechwagen	heavy telephone wagon
Nf 2	leichter Fernsprechwagen	light telephone wagon
Nf 4	kleiner Funkwagen	small radio wagon
Nf 5	kleinfunkwagen	small radio wagon
Nf 6	Funkwagen	radio wagon
Nf 7	Infanterie-Nachrichtenwagen	infantry signal wagon
Nf ?	Bauwagen 13	construction equipment wagon
Nf ?	Leiterwagen für Fernsprechrupp	ladder wagon for telephone section
Nf ?	Kastenwagen für Fernsprechrupp	equipment wagon for telephone section

<b>Pf</b>	<b>= Pionierfahrzeuge</b>	<b>Engineer Vehicles</b>
Pf 21	Flammenwerfer-Füllwagen	flamethrower refill wagon
Pf 22	Pionierhandkarren	engineer hand cart
Pf 25	Handkarren für leichten Landungswerfer	hand cart for light spigot mortar

<b>Sf</b>	<b>= Sanitätsfeldwagen</b>	<b>Medical Field Wagons</b>
Sf 1	Krankenwagen	ambulance wagon
Sf 2	Krankenwagen	ambulance wagon

<b>Vf</b>	<b>= Fahrzeuge der Veterinärtruppen</b>	<b>Wagons for Veterinary Troops</b>
Vf 1	Pferdetransportwagen	horse transport wagon

<b>Vwf</b>	<b>= Fahrzeuge der Verwaltungstruppen</b>	<b>Wagons for Administration Troops</b>
Vwf 1	Backofentransportwagen	oven transport wagon
Vwf 2	Teigknetwagen	dough mixer wagon
Vwf 3	Kraftquellenwagen	water pump wagon

<b>Fahrzeuge ohne Numerierung</b>	<b>Wagons without Numbers</b>
— Pleskau-Wagen I	Pleskau I (359 kilo) (1 horse team)
— Pleskau-Wagen II	Pleskau II (700 kilo) (2 horse team)
— Kutschwagen	carriage / coach
— grosser Feldwagen (t)	large Czech field wagon
— kleiner Feldwagen (t)	small Czech field wagon
— grosser Feldküche (t)	large Czech field kitchen
— kleiner Feldküche (t)	small Czech field kitchen
— Gebirgskarren M15 für Munition (t)	Czech mountain cart for ammunition

<b>Hs</b>	<b>= Heeresschlitten</b>	<b>Army Sleds</b>
Hs 1	Schlitten (300 Kg)	sled (300 Kilo) (single or tandem)
Hs 3	Schlitten (500 Kg)	sled (500 Kilo) (single or tandem)
Hs 3/1	Krankenschlitten	stretcher sled (single or tandem)
Hs 5	Schlitten (1000 Kg)	sled (1000 Kilo) (single or tandem)
Hs 41	zweispännige Schlitten	sled (dual)
Hs 42	zweispännige Schlitten	sled (dual)
Hs 43	zweispännige Schlitten	sled (dual)
Hs 61	einspännige Schlitten	sled (single)
Hs 62	einspännige Schlitten	sled (single)

## GERMAN ARMY RANKS AND *STELLEGRUPPEN* (BILLET GROUPS)

This is only a simplified account of the German military personnel structure and hierarchy. Readers are warned that, as in all armies, they were in actual fact more complicated, with important differentiations being made between designations of rank, billet, function, and skill.

'Billet' indicates an appointment to (staffing of) a position – also called a 'slot' – like Squad Leader, Platoon Commander, Divisional Commander, Executive Officer, Supply Sergeant, etc. Confusingly, in some cases, the billet has the same designation as a rank, such as Hauptfeldwebel.

The equivalent Ranks given in English are neither completely World War II British nor American, and is not going to satisfy any specialist. (However a specialist would probably not be reading this anyway). Nearly all German officer ranks correspond to US Army ranks, although their terminology differs, a *Generalmajor* being the equivalent of a brigadier general. Modern US Army rank equivalents have some differences. There is one more enlisted rank (Command Sergeant Major), and one more Warrant Officer rank (Warrant Officer 3rd Class). US Army Warrant Officers are counted as officers, not enlisted men. In the German WWII Army, all ranks below 2nd Lieutenant were enlisted men.

The German Army divided officers billets into eight groups, depending on the function to be carried out. German wartime officer ranks were permanent, which often made it impossible for German officers to be promoted to the higher rank which their wartime billet would actually have warranted. For example, although a Captain normally staffed the billet of Company Commander, this was not always a rule. If there were not enough Captains then a senior member of a lower rank was assigned to that billet. Conversely, if there were too many of a higher rank than one or more might be assigned a lower ranking billet. Many Divisions were commanded by a Brigadier General - and even an occasional Colonel - instead of a Major General. Conversely, if a billet was particularly critical, a higher-ranking person might be assigned to that billet than would normally be the case. Skill was preferred to rank. Promotion was achieved by serving time. The function or billet filled as such was not a ground for promotion.

The enlisted men were divided into three billet groups: Senior Sergeants (Unteroffiziere mit Portepee) ("O" Group), Junior Sergeants (Unteroffiziere ohne Portepee) ("G" Group), and Other Ranks (Mannschaften) ("M" Group).

Enlisted members of the German Army had an 'Occupation' (Laufbahn), i.e. a career or field of specialty, like Infantry, Supply, Finance and so on. The occupation might be incorporated into the rank designation, such as *Beschlagschmiedobergefreiter*, a farrier (horseshoe smith) corporal; or even be used instead of the rank designations, such as *Beschlagmeister*, ('Farrier Master'), who was an expert farrier sergeant.

The highest combat leader position held by an enlisted man was that of platoon leader. However, this usually applied only to the third and fourth platoons. All other combat command positions were held by officers. Sergeants and Warrant Officers were in charge of logistics and administration, freeing the officers for their primary function of leading men into combat. It was not unusual for senior enlisted men to become involved in combat when the need arose, although the German Army considered it a waste of skilled manpower to use these highly trained and experienced men for this purpose.

German Tables of Organization (KStN – *Kriegsstärkenachweisungen*) had many notes indicating which billets and specialist slots were to be filled with what ranks and specialists, listing which billets had priority over others, which could alternatively be filled by a person with specialized knowledge or skill, and which billets should by preference be filled with regular army personnel.

Although it was expected to have rank and billet corresponding to each other, this was far from the case. Specialist personnel was rare and many units were raised in a hurry, not having enough time to acquire all its correct personnel. And once a unit entered combat, the chances of acquiring the exact, highly-skilled soldier for the correct position often became merely a matter of luck.

The German Wehrmacht also had a unique category of personnel within its ranks, namely the *Wehrmachtbeamten*, which can be loosely translated as Armed Forces Civil Servants or as Government Service Officials. They were found in administrative, legal, and technical service positions. They were civilians performing functions within the Armed Forces. Although they were not classified as soldiers, they wore uniforms identical with those of the Service branch they were serving with, albeit with different insignia. Their duties, at least at field and company level, could lead to armed encounters with enemy forces, and they were all armed with pistols.

### Generals

#### Billet Group "A"

Commander-in-Chief / General Officer in an "A" Group  
*Oberbefehlshaber / General in A-Stelle*  
 Generalfeldmarschall ..... General of the Army (Field Marshal)  
 Generaloberst ..... General

#### Billet Group "F"

Commanding General / General Officer in an "F" Group  
*Kommandierender General / General in F-Stelle*  
 General ..... Lieutenant General  
 der Infanterie ..... of the Cavalry  
 der Kavallerie ..... of the Infantry  
 der Artillerie ..... of the Artillery  
 der ... ..... of the ...

#### Billet Group "D"

Divisional Commander / General Officer in a "D" Group  
*Divisionskommandeur / General in D-Stelle*  
 Generalleutnant ..... Major General  
 Generalstabsarzt ..... Major General (Medical Corps)  
 Generalstabs- ..... Major General (...)

#### Billet Group "I"

Infantry, Artillery, or Brigade Commander / General Officer in an "I" Group  
*Infanterie-, Artillerie-, Brigadekommandeur / Offizier in I-Stelle*  
 Generalmajor ..... Brigadier General  
 Generalarzt ..... Brigadier General (Medical Corps)  
 General- ..... Brigadier General (...)

### Officers

#### Billet Group "R"

Regimental Commander / Officer in an "R" Group  
*Regimentskommandeur / Offizier in R-Stelle*  
 Oberst ..... Colonel  
 Oberstarzt ..... Colonel (Medical Corps)  
 Oberst- ..... Colonel (...)

#### Billet Group "B"

Battalion Commander / Officer in a "B" Group  
*Abteilungs- bzw. Bataillonskommandeur / Offizier in B-Stelle*  
 Oberstleutnant ..... Lieutenant Colonel  
 Oberfeldarzt ..... Lieutenant Colonel (Medical Corps)  
 Oberfeld- ..... Lieutenant Colonel (...)  
 Major ..... Major  
 Oberstabsarzt ..... Major (Medical Corps)  
 Oberstabs- ..... Major (...)

#### Billet Group "K"

Battery, Squadron, or Company Commander / Officer in a "K" Group  
*Batterie-, Schwadron- bzw. Kompanieführer / Offizier in K-Stelle*  
 Hauptmann ..... Captain  
 Rittmeister ..... Captain (Cavalry Corps)  
 Stabsarzt ..... Captain (Medical Corps)  
 Stabsveterinär ..... Captain (Veterinary Corps)  
 Stabsmusikmeister ..... Captain (Band)  
 Stabs- ..... Captain (...)

#### Billet Group "Z"

Platoon Leader / Officer in a "Z" Group  
*Zugführer / Offizier in Z-Stelle*  
 Oberleutnant ..... First Lieutenant  
 Oberarzt ..... First Lieutenant (Medical Corps)  
 Obermusikmeister ..... First Lieutenant (Band)  
 Oberzahlmeister ..... First Lieutenant (Paymaster Corps)  
 Ober- ..... First Lieutenant (...)  
 Leutnant ..... Second Lieutenant  
 Assistenzarzt ..... Second Lieutenant (Medical Corps)  
 Musikmeister ..... Second Lieutenant (Band)  
 Assistenzzahlmeister ..... Second Lieutenant (Paymaster Corps)  
 Assistenz- ..... Second Lieutenant (...)

### Enlisted Men

#### Billet Group "O"

Senior Non-Commissioned Officer in an "O" Group  
*Oberfeldwebel (Unteroffiziere mit Portepee)*  
 Stabsfeldwebel ..... Warrant Officer First Class  
 Obermeister ..... Warrant Officer 1st Class of a Technical Establishment  
 Hauptfeldwebel ..... Warrant Officer 2nd Class  
 Hauptwachtmeister ..... Warrant Officer 2nd Class (Cavalry, Artillery, AA, etc.)  
 Oberfeldwebel ..... Sergeant Major  
 Oberwachtmeister ..... Sergeant Major (Cavalry, Artillery, AA, etc.)  
 Musikleiter ..... Sergeant Major (Band)  
 etc. ....  
 Feldwebel ..... First Sergeant  
 Wachtmeister ..... First Sergeant (Cavalry, Artillery, AA, etc.)  
 Beschlagmeister ..... Farrier First Sergeant  
 Feuerwerker ..... Ordnance First Sergeant  
 Brieffaubenmeister ..... Pigeon Postmaster  
 etc. ....

#### Billet Group "G"

Non-Commissioned Officer in a "G" Group  
*Gruppenführer (Unteroffiziere ohne Portepee)*  
 Unterfeldwebel ..... Staff Sergeant  
 Unterwachtmeister ..... Staff Sergeant (Cavalry, Artillery, AA, etc.)  
 etc. ....  
 Unteroffizier ..... Sergeant  
 Sanitätsunteroffizier ..... Sergeant (Medical Corps)  
 etc. ....  
 Obergefreiter ..... Corporal  
 Sanitätsobergefreiter ..... Corporal (Medical Corps)  
 etc. ....

#### Billet Group "M"

Other Rank in an "M" Group  
*Mannschaft*  
 Gefreiter ..... Private First Class  
 Oberschütze ..... Private 2  
 Oberreiter ..... Trooper First Class  
 etc. ....  
 Schütze ..... Private 1 (infantryman)  
 Grenadier ..... Private (alternate designation for infantryman)  
 Jäger ..... Private (Mountain or Light Infantry)  
 Pionier ..... Engineer / Pioneer (Engineers)  
 Fahrer ..... Driver (usually of a horse-drawn vehicle)  
 Kraftfahrer ..... Driver (motor vehicle)  
 Beschlagschmiedschütze ..... Farrier (horse smith)  
 Spielman ..... Bandsman / Bugler  
 etc. ....

## GERMAN MILITARY PERSONNEL JOB DESCRIPTIONS

Abteilungsarzt	Battalion Physician	Melder	Messenger / Runner
Abteilungskommandeur	Battalion Commander	Meldereiter	Messenger (horse-mounted)
Abteilungsschreiber	Battalion Headquarters Clerk	Mitarbeiter	Assistant Clerk
Abteilungsveterinär	Battalion Veterinary Doctor	Motorschlosser	Motor Mechanic
Adjutant	Adjutant	Munitionskanonier	Ammunition Handler
Arzt	Physician	Munitionsschütze	Ammunition Handler
Auswerter	Plotter / Evaluator	Musiker	Bandsman
Autoschlosser	Motor Vehicle Mechanic	Musikmeister	Band Leader
Bataillonsarzt	Battalion Physician	Nachrichtenmechaniker	Signals Technician
Bataillonskommandeur	Battalion Commander	Nachrichtenoﬃzler	Signal Officer
Bataillonsveterinär	Battalion Veterinary Doctor	Nachrichtenunteroﬃzler	Signal NCO
Batterieführer	Battery Commander	Oﬃzler	Officer
Batterieoﬃzler	Firing Battery Commander	Ordnanzoﬃzler	Aid (-de-Camp) (officer)
Batterieschreiber	Battery Headquarters Clerk	Ordnanz	Orderly (enlisted)
Beamte	Armed Forces Civil Servant / Government Service Official / Civilian Employee in Military Service	Panzerbüchenschütze	Antitank Rifleman
Beobachter	Observer	Panzerelktromechaniker	Armored Vehicle Electrician
Beobachtungsoﬃzler	Observation Officer	Panzerelktroschweisser	Armored Vehicle Arc Welder
Beschlagschmied	Farrier / Horseshoe Smith	Panzerführer	Armored Vehicle Commander
Betreuungsoﬃzler	Entertainment Officer	Panzerfunkwart	Armored Vehicle Radio Repairman
Bootsmann	Boat Operator	Panzergetriebenschlosser	Armored Vehicle Drive Train Mechanic
Chef des Stabes	Chief of Staff	Panzerjägerführer	Antitank Vehicle Commander
Divisionionsarzt	Division Physician	Panzermotorschlosser	Armored Vehicle Motor Mechanic
Divisionskommandeur	Division Commander	Panzerschlosser	Armored Vehicle Mechanic
Dolmetscher	Interpreter	Panzerschützen	Infantryman in an Armored Vehicle
Dreher	Lathe Operator	Panzerwart	Armored Vehicle Mechanic
Drucker	Printer	Peiler	Direction Finder
Elektriker	Electrician	Pferdeführer	Horse Leader. Driver on foot of a horse-drawn wagon
Elektromechaniker	Electro Mechanic	Pferdehalter	Horse Holder (Groom)
Entfernungsmesser	Rangefinder / Distance Measurer	Pferdewärter	Groom (Horse Holder)
Erkunder	Scout	Pionier	Pioneer / Engineer / Sapper
Erkundungsoﬃzler	Observation Officer	Planoffizier	Triangulation Officer
Facharbeiter	Specialist	Postfachkraft	Postal Worker
Fahnenschmied	Farrier NCO	Prüfer	Accounts Controller
Fahrer	Driver	Quartiermeister	Quartermaster
Fahrer vom Bock	Wagoner. (Driver of a horse-drawn vehicle sitting on the driver's box)	Rechner	Calculator
Fahrer vom Sattel	Horse Team Leaders. (Drivers of a horse-drawn vehicle sitting on the horses)	Rechnungsführer	Accountant
Feinmechaniker	Optics Technician	Regimentsadjutant	Regiment Adjutant
Feldfunksprecher	Field Radio Operator	Regimentsarzt	Regiment Physician
Feldgendarm	Military Policeman	Regimentskommandeur	Regiment Commander
Feldkoch	Cook	Regimentskraftfahreroﬃzler	Regiment Motor Officer
Feldkochunteroﬃzler	Cook NCO	Regimentschreiber	Regiment Headquarters Clerk
Feldwebel	Sergeant	Regimentsveterinär	Regiment Veterinary Doctor
Fernsprecher	Telephonist	Richter	Judge
Feuerwerker	Ordnance NCO	Richtkreisuﬃzler	Gun Layer NCO / Gun Director NCO
Flakwaffenwart	Antiaircraft Weapon Armorer	Richtmeister	Master Fitter
Flugmeldeauswerter	Air Observation Evaluator	Richtschütze	Gunner
Flugmelder	Air Observer	Sachbearbeiter	Clerk
Führer	Leader	Sanitätssoﬃzler	Medical Officer
Führer der Gefechtsfahrzeuge	Leader of the Company/Battery Vehicles	Sanitätsunteroﬃzler	Medical NCO
Funker	Radio Operator	Sattelpferd	Near Horse
Funkmeister	Senior Radio Operator	Sattler	Saddler / Harness Maker
Funkwart	Radio Repairman	Scharenfernrohrunteroﬃzler	Scissors Telescope NCO
Futtermeister	Fodder NCO	Schirmmeister	Foreman / Harness Keeper / Storekeeper NCO / Maintenance Technical Sergeant
Gaschützunteroﬃzler	Chemical Warfare NCO	Schleifer	Polisher
Gefechtsschreiber	Headquarters Clerk	Schlosser	Mechanic
Gerätverwalter	Equipment Administrator	Schmied	Smith
Gerätwart	Equipment Repairman	Schneider	Tailor
Geschützbedienung	Gun Crew	Schreiber	Clerk
Geschützführer	Gun Layer / Gun Captain / Gun Commander	Schumacher / Schuster	Shoemaker / Cobbler
Getriebeschlosser	Drive Train Mechanic	Schwadronführer	Company Commander (cavalry arm)
Gruppenführer	Section Leader	Schwadrontruppführer	Company Headquarters Section Leader (cavalry arm)
Handwerker	Craftsman	Schweisser	Welder
Hauptfeldwebel	Senior Company NCO / Company First Sergeant	Spähtruppführer	Scout Section Leader
Hauptwachmeister	Senior Battery NCO / Battery First Sergeant	Staffelführer	Detachment Leader
Hilfsbeobachter	Assistant Observer	Stellmacher	Cartwright / Wheelwright
Hilfsprüfer	Assistant Controller	Stellungsunteroﬃzler	Gun Position NCO
Hiwi (Hilfswilliger)	Foreign Volunteer for Military Service	Steuermann	Helmsman (driver of a boat)
Holzarbeiter	Wood Worker	Tankwart	Fuel Handler
Intendant	Commissary Officer	Tischler	Joiner / Cabinet Maker
Kanonier	Gunner	Trossführer	Trains Leader
Kartenzeichner	Cartographer	Truppenarzt	Troop Doctor
Kettenkraftradfahrer	Kettenrad Driver	Truppführer	Team Leader
Klempner	Plumber	Unteroﬃzler	NCO (Non-Commissioned Officer)
Koch	Cook	Urkundsbeamter	Document Clerk
Kommandant	Commandant	Verbindungssoﬃzler	Liaison Officer
Kommandeur	Commander	Vermessungsdienst	Measuring Service
Kompanieführer	Company Commander	Verpflegungsmann	Rations Handler
Kompanietrossführer	Company Trains Leader	Verpflegungsunteroﬃzler	Rations NCO
Kompanietruppführer	Company Headquarters Section Leader	Veterinärsoﬃzler	Veterinary Officer
Kradmelder	Motorcycle Messenger	Vorgeschobener Beobachter	Forward Observer
Kraftfahrzeugelektriker	Motor Vehicle Electrician	Vorhandwerker	Leading Craftsman
Kraftfahrzeugmotorschlosser	Motor Vehicle Motor Mechanic	Vorreiter	Outrider. Escort on horse-back of a horse-drawn vehicle.
Kraftfahrzeugschlosser	Motor Vehicle Mechanic	Vorwamer	Advance Warning Man
Kraftwagenbeifahrer	Motor Vehicle Codriver	Waffenmeister	Armorer
Kraftwagenfahrer	Motor Vehicle Driver	Waffenmeisterhilfe	Assistant Armorer
Krankenträger	Stretcher Bearer	Waffenmeisterunteroﬃzler	Master Armorer NCO
Ladeschütze	Loader	Waffenunteroﬃzler	Armorer NCO
Laufwerkschlosser	Running Gear Mechanic	Wagenbegleiter	Wagon Escort. Escort of a horse-drawn vehicle on foot
Leiter	Chief Leader	Wagenführer	Leader of the vehicles in the trains
Lichtpauser	Photographer	Werferführer	Launcher or Mortar Gunner
Maler	Painter	Werkmeister	Foreman / Chief Technician
Mann	(Enlisted) Man	Zahlmeister	Paymaster / Finance Officer
Mannschaft	Privat / Other Rank / (Enlisted) Man	Zeichner	Draftsman
Maschinengewehrschütze	Machine Gunner	Zimmermann	Carpenter
Meldefahrer	Motor Vehicle Messenger	Zugführer	Platoon Leader
Meldefahrer	Messenger (motor vehicle)	Zugtruppführer	Platoon Headquarters Section Leader