

GERMAN WORLD WAR II ORGANIZATIONAL SERIES

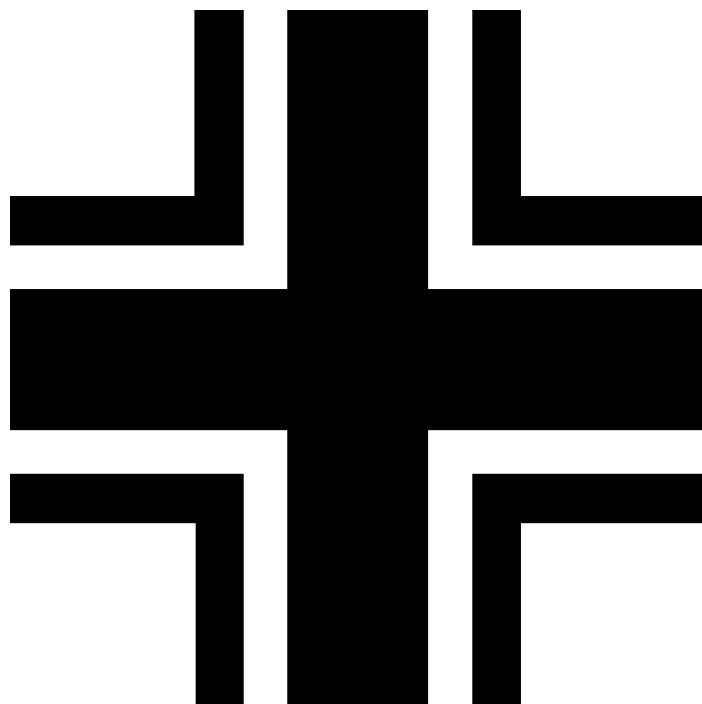

Volume 5/III

**WAFFEN-SS HIGHER HEADQUARTERS AND MECHANIZED FORMATIONS
(4 July 1943)**

THE GERMAN WORLD WAR II ORGANIZATIONAL SERIES

1/I	01.09.39	Mechanized Army Formations and Waffen-SS Formations (3rd Revised Edition)
1/II-1	01.09.39	1 st and 2 nd Welle Army Infantry Divisions
1/II-2	01.09.39	3 rd and 4 th Welle Army Infantry Divisions
1/III	01.09.39	Higher Headquarters — Mechanized GHQ Units — Static Units (2nd Revised Edition)
2/I	10.05.40	Mechanized Army Formations and Waffen-SS Formations (2nd Revised Edition)
2/II	10.05.40	Higher Headquarters and Mechanized GHQ Units (2nd Revised Edition)
3/I	22.06.41	Mechanized Army Divisions - (2nd Revised Edition)
3/II	22.06.41	Higher Headquarters and Mechanized GHQ Units (2nd Revised Edition)
4/I	28.06.42	Mechanized Army Divisions - (2nd Revised Edition)
4/II	28.06.42	Mechanized GHQ Units and Waffen-SS Formations
5/I	04.07.43	Mechanized Army Formations
5/II	04.07.43	Higher Headquarters and Mechanized GHQ Units
5/III	04.07.43	Waffen-SS Higher Headquarters and Mechanized Formations

IN PREPARATION FOR PUBLICATION 2007/2008

7/I	06.06.44	Mechanized Army Formations
2/III	10.05.40	Army Infantry Divisions
3/III	22.06.41	Army Infantry Divisions

IN PREPARATION FOR PUBLICATION

01.09.39	Landwehr Division — Mountain Divisions — Cavalry Brigade
10.05.40	Non-Mechanized GHQ Units Static Units
22.06.41	Mechanized Waffen-SS Formations Static Units
28.06.42	Higher Headquarters Army Divisions Static Units
04.07.43	Army Divisions Static Units
01.11.43	Mechanized Army Formations Mechanized GHQ Units Mechanized Waffen-SS Formations Army Divisions Static Units Higher Headquarters
06.06.44	Mechanized GHQ Units Mechanized Waffen-SS Formations Army Divisions Static Units Higher Headquarters
16.12.44	Mechanized Army Formations Mechanized GHQ Units Mechanized Waffen-SS Formations Army Divisions Static Units Higher Headquarters
1939 – 45	Luftwaffen Ground Combat Forces
1944 – 45	The 1944 Brigades
1939 – 45	Organizational Handbook

GERMAN WORLD WAR II ORGANIZATIONAL SERIES

by Leo W.G. Niehorster

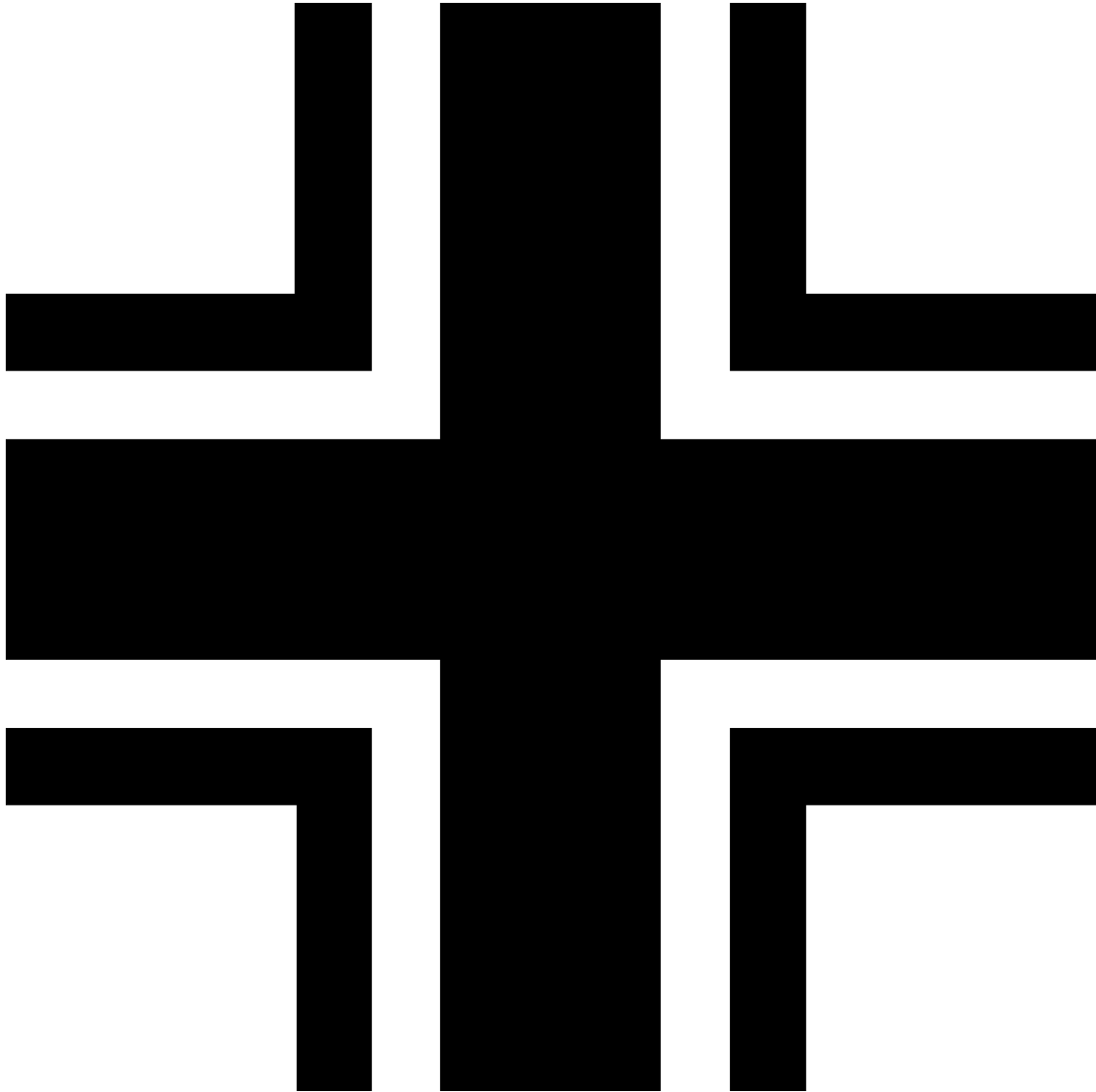

Volume 5/III

**WAFFEN-SS HIGHER HEADQUARTERS AND MECHANIZED FORMATIONS
(4 July 1943)**

GERMAN WORLD WAR II ORGANIZATIONAL SERIES

Volume 5/III

Waffen-SS Higher Headquarters and Mechanized Formations
(4 July 1943)

First published by The Military Press in 2005

Reprinted by The Military Press in 2007

This and all previous editions © by Leo W.G. Niehorster

THE MILITARY PRESS

1 Gallagher Close

Crownhill, Milton Keynes

Buckinghamshire MK8 OLQ

United Kingdom

Tel: +44 (190) 826-5095

Fax: +44 (870) 912-0908

email: militarypress@btopenworld.com

<http://www.militarypress.co.uk>

All rights reserved. Except for use in a review, no portion of this book may be reproduced, stored in a retrieval system or transmitted in any form or means, electronic, electrostatic, magnetic tape, mechanical, photocopying, or otherwise without the express prior, written permission of the publisher. Neither the author nor the publisher assumes any responsibility for the use or misuse of information contained in this book.

Printed in the United Kingdom

ISBN 978-0-85420-780-0 Hardback Edition
ISBN 978-0-85420-785-5 Softback Edition

CONTENTS

Waffen-SS Higher Headquarters and Mechanized Formations

<p>1 Contents</p> <p>2 The Author</p> <p>3 General Introduction</p> <p>4 How to Read the Charts</p> <p>5 Germans Units and Symbols</p> <p>6 Organizational Symbols</p> <p>8 Abbreviations</p> <p>9 Order of Battle</p> <p>10 SS-Panzer Corps</p> <p>11 SS-Panzer Corps Headquarters</p> <p>13 SS-Panzer Corps Signal Battalion (motorized)</p> <p>14 SS Heavy Tank Battalion</p> <p>15 SS Rocket Launcher Battalion (motorized)</p> <p>16 Commander of SS-Panzer Corps Supply Troops</p> <p>17 SS-Panzer Corps Motorized Medical Battalion</p> <p>18 SS-Mountain Corps</p> <p>19 SS-Mountain Corps Headquarters</p> <p>21 SS Tank Battalion</p> <p>22 SS Assault Gun Battalion</p> <p>23 SS Rocket Launcher Battalion</p> <p>24 SS Motorized Heavy Artillery Battalion</p> <p>25 SS Antiaircraft Battalion</p> <p>26 SS Motorcycle Battalion</p> <p>27 SS-Mountain Corps Alpine Battalion</p> <p>28 SS Motorized Signal Battalion</p> <p>29 SS-Mountain Corps Motorized Medical Battalion</p> <p>30 Commander of SS-Mountain Corps Supply Troops</p> <p>31 SS-Panzer Grenadier Division Leibstandarte SS-Adolf Hitler</p> <p>32 SS-Panzer Grenadier Division Das Reich</p> <p>33 SS-Panzer Grenadier Division Totenkopf</p> <p>34 SS-Polizei-Panzer Grenadier Division</p> <p>35 SS-Panzer Grenadier Division Wiking</p> <p>36 SS-Panzer Grenadier Division Hohenstaufen</p> <p>37 SS-Panzer Grenadier Division Karl der Grosse</p>	<p>38 SS-Panzer Grenadier Division Nordland</p> <p>39 SS-Panzer Grenadier Division Hitlerjugend</p> <p>40 SS-Panzer Grenadier Division Nederland</p> <p>41 Sturmbrigade Reichsführer-SS</p> <p>42 SS-Brigade 1 Reichsführer-SS</p> <p>43 SS-Sturmbrigade Wallonien</p> <p>44 SS-Sturmbrigade Langemark</p> <p>45 Headquarters, Motorized SS Infantry Brigade</p> <p>46 Headquarters, SS-Panzer Grenadier Division</p> <p>47 Waffen-SS Armored Fighting Vehicles Strengths on 30.06.1943</p> <p>48 SS Tank Regiment</p> <p>49 SS Assault Gun Battalion</p> <p>50 LSSAH Panzer Grenadier Regiment</p> <p>52 SS Panzer Grenadier Regiment</p> <p>54 Sturmbrigade Reichsführer-SS</p> <p>56 SS Assault Brigade</p> <p>58 SS Motorized Artillery Regiment</p> <p>60 SS Motorized Antiaircraft Battalion</p> <p>62 SS Mechanized Antitank Battalion</p> <p>63 LSSAH Armored Reconnaissance Battalion</p> <p>64 SS Armored Reconnaissance Battalion</p> <p>65 SS Motorized Reconnaissance Battalion</p> <p>66 SS Motorized Combat Engineer Battalion</p> <p>67 LLSAH Division Armored Signal Battalion</p> <p>68 SS Panzer Grenadier Division Signal Battalion</p> <p>69 Motorized SS Brigade Signal Company</p> <p>70 SS Panzer Grenadier Division Support Services</p> <p>72 Bibliography</p> <p style="padding-left: 20px;">i Introduction to Motor Vehicles</p> <p style="padding-left: 20px;">ii Numbered Motorized Softskin Vehicles</p> <p style="padding-left: 20px;">iv Special Motorized Vehicles</p> <p style="padding-left: 20px;">x Military Trailers and Special Military Trailers</p> <p>xiii Horse-Drawn Vehicles: Wagons, Carts, Sleds</p> <p>xv Ranks and Billet Groups of the German Army</p> <p>xvi German Military Personnel Job Descriptions</p>
---	---

THE AUTHOR

Dr. Leo Niehorster was born in The Hague, Netherlands of an American mother and Dutch father. He has lived in Holland, Peru, England, Mexico, Canada, the United States, France, and Germany. His university education has been correspondingly diverse. The University of the Americas in 1964 to 1967, University of Maryland (correspondence courses while in the US Army) from 1968 to 1972, European Business School 1972 to 1976 (BA in Business Administration), Frankfurt Fachhochschule 1978 (Dipl. Kaufmann), Columbia Pacific University 1978 to 1980 (External MA in Business Administration), Columbia Pacific University 1980 to 1982 (External PhD in History). His vocational training includes a course resulting in the degree of Telecommunications Systems Developer. He is also a licensed Apple Service Technician.

The author did his military service in the US Army from 1968 to 1972, ending up in Germany, where he stayed.

His professional career started as night shift supervisor in an airline catering service, and has spanned such activities as pizza baker at the local Italian in Barstow, California, to

product manager for long haul travel in the world's largest tour operator in Hannover, Germany. He spends most of his spare time involved in military history.

The author is a recognized authority on World War II German ground forces organization, and has put all of his expertise into the present series. Some of these books are a republishing of the original series, (which have been out of print for several years), and they have been enhanced and augmented, encompassing a further fourteen years of research and study in the German, American, and British archives. The revised editions as well as the new volumes in the series will be highly welcomed by all interested in German military organization in World War II.

Dr. Niehorster's previously published works include "The Royal Hungarian Army, 1920-1945", which was acclaimed as one of the Top Ten Books of 1999, and is considered by many experts to be the single most important English language history on the Hungarian Army. As of 2004, he also coedits the ongoing "German Army 1939-1945: An Order of Battle" with Lowry Cole.

GENERAL INTRODUCTION

The designation Waffen-SS has been used for SS field combat units, as opposed to strictly political or paramilitary units of the SS, which were on occasion also used in combat.

The 1942 campaigns had ended disastrously for the Germans. The 6th Army capitulated in Stalingrad in February 1943. The 4th Panzer Army barely escaped a similar fate in the Caucasus in March 1943. Army Group Afrika surrendered in Tunisia in May 1943. Not to mention other events, such as the U-Boat war in the North Atlantic.

Through enormous effort, by mid-1943 the Germans had recovered to some extent although not all units were up to their full strength.

The big German offensive in July 1943 resulted in the Battle of Kursk, where the Russians soundly defeated the German armed forces for the second time on the East Front within five months.

Rebuilding was hampered by the lack of equipment. Soft-skinned motor vehicles were never produced in sufficient numbers to satisfy the needs of the tables of organization (Kriegsstärkenachweisung – KStN). The lack of German equipment was compensated to a certain extent by the wholesale incorporation of captured Russian, Czech, British, and French, vehicles, guns, artillery, etc.

On 1.03.1943, General Heinz Guderian was appointed Inspector General of the Panzertruppen (Armored Forces). This meant that the organization of just about all mechanized units, (including those of the Infantry Inspectorate, the Luftwaffe, and the even the Waffen-SS) came under his control.

The Waffen-SS was not part of the Wehrmacht (German Armed Forces), but formed a separate, broadly speaking, fourth service. It was subject only to Wehrmacht orders for operational use, and drew its supplies just as regular Army formations did. Replacements, disciplinary matters and “morale” education were reserved for the Reichsführer-SS (the leader of all the German SS organizations).

There is no martial reason for Waffen-SS units to be considered as elite. But the Waffen-SS captured the imagination of both the German population in WWII, and many historians after this era consider the Waffen-SS units as elite units, whose status frequently brought with it higher casualties and losses. While it is true that Waffen-SS units were often thrown into the hottest part of the fight – by the Army, probably because they were not of their own – by the Nazi party, because they were there to prove the superiority of the Nazi doctrine and spirit, the impact of the Waffen-SS on the actual course of the war was no different than that of the Army, and played no significant, irreplaceable operational or strategic role during the war. The Waffen-SS had no role at all in developing German blitzkrieg tactics and played no vital role in any of Germany’s blitzkrieg victories. It introduced no original military developments of any significance, and drained manpower and equipment from the Army.

The Waffen-SS depended upon the Army. The performance of the so-called “elite” Panzer divisions, (basically the only ones with a respectable military record in World War II), show no greater merit or skill than that of the Army. Nor were the Waffen-SS losses a great deal higher than the Army’s. The Totenkopf Division, which suffered the most casualties, lost no more men than the Army’s Grossdeutschland division – the only German Army division able to recruit across Germany, on a similar basis to the Waffen-SS.

The Waffen-SS created its first corps echelon field command in 1942, the SS-Panzer-Generalkommando. The 1943 SS-Panzerkorps were similar to the Army Panzerkorps (with corps headquarters, signal battalion, supply command, field post, military police, mapping units, etc.), but with additional units, (a heavy Panzer battalion, a rocket launcher battalion, supply and medical elements.) The idea starting in 1943 was that there were to be one SS corps for every two SS divisions or three brigades. The concept was not rigidly adhered to, however. In some cases, three divisions and or several brigades were to be subordinate. The divisions initially considered for subordination under a specific corps did not necessarily end up being commanded by that corps. The corps were organized differently depending on the types of divisions to be commanded. In most cases, the subordinate divisions were only loosely attached, could and did operate independently.

The first mountain corps, raised at this time to control mountain divisions in the Balkans, had specialized units designed to enable them to operate more or less independently.

The reason for the extra corps units is quite basic. The SS had, at the time of the creation of the SS-Panzerkorps, (and the other SS corps), no “GHQ”

troops of its own. [Even the Waffen-SS divisions had always had more units than their Army counterparts – for several reasons, of course, one being that, initially, there were no Waffen-SS non-divisional units.] The Army had its Heerestruppen, which were used to create main points of effort, or provide higher echelon support. The Waffen-SS did not. The “corps” troops were redesignated as “Sondertruppen der RFSS”, (which was the Waffen-SS equivalent to the Heerestruppen), as soon as there were enough to warrant a separate branch; the units the corps had were more of a foot in the door for even more Waffen-SS units, rather than a fixed feature within the corps organization.

Because of a this lack of rear area support units, Waffen-SS regiment and battalion staffs were authorized extra medical personnel over and above the normal organization with a few vehicles more to support them. The headquarters, heavy company, and the motorcycle company had an additional field kitchen mounted on a truck. All regiment and battalion staffs were authorized some extra administrative personnel. Both Corps and Division headquarters had a Political Education Officer (V) with a staff of about a dozen men.

The SS wanted to keep as much control over their units as possible. The more higher commands, the more direct control. And the ultimate aim of the SS was to become independent of the Army and then replace it completely, at least when victory was finally achieved. Wanting to have SS officers with practical experience in commanding larger formations is a natural consequence of this thinking. And, following this concept to the its logical conclusion, Waffen-SS officers were finally also put in command of armies.

The Waffen-SS designated all its mechanized divisions as Panzergrenadier-Divisions in 1942 – although they were in fact quite strong Panzer Divisions. This was remedied in October 1943, when they were redesignated as Panzer-Divisions. In addition to these armored divisions, the Waffen-SS also raised motorized infantry divisions, designated as Panzergrenadier Divisions, similar in concept to the Army motorized infantry divisions.

Waffen-SS Panzergrenadier Divisions had three infantry regiments, whereas the Army equivalent only had two, and then these regiments were more lavishly equipped than their Army counterparts. All four of the mechanized divisions had an antiaircraft battalion, whereas only three of the ten Army Panzergrenadier Divisions did. Three had a Sturmgeschütz battalion; the fourth would soon receive one. However, Army divisions frequently had GHQ units attached for specific missions.

Three of the Waffen-SS Panzergrenadier-Divisions (Leibstandarte-SS Adolf Hitler, SS-Das Reich, SS-Totenkopf), had an armored regiment and a Sturmgeschütz battalion. (A fourth, the SS-Wiking Division was also to have this organization, and a fourth armored regiment was in the process of being raised for it. A Sturmgeschütz battalion would join the division later).

The Waffen-SS was engaged in raising or converting a series of mechanized units at this time. On 4.07.1943 all these formations were in the process of being raised, and either existed mostly on paper – consisting merely of understrength groups of personnel in training with little if any authorized equipment – or, in other cases, Regular-SS units being reorganized as Waffen-SS formations. Organizational diagrams for these formations have been depicted in this volume, but readers are cautioned that these are those planned and authorized at the beginning of July 1943. They would undergo a series of changes before they achieved their final form at the end of the training period, or with which the formations would first enter combat. They have not been further discussed in the unit breakdowns.

I would like to mention the following for their time and assistance: Martin Block, Piet Duits, Kurt Gätzschmann, Thomas L. Jentz, Brün Meyer; Adolf Schönefeld, Simon Vosters. To all of them, my thanks.

This book draws primarily on German tables of organization (KStN) – both of the Army and the Waffen-SS – and various orders of battle.

The published material contained in the sources and references section indicates publications which were consulted, (although not necessarily used), and is basically meant to assist the reader in familiarizing himself with the subject of the Waffen-SS mechanized units of the period.

The author apologizes for any mistakes that have happened during this process, (they are only my own), and welcomes critical comments and suggestions. Should any reader possess more founded information, or even the original documents thereto, I would appreciate hearing from them, so that in a future edition, the corresponding corrections can be inserted for the benefit of all.

HOW TO READ THE CHARTS

Dates are indicated in the following manner: Day.Month.Year. (Thus 4.07.1943 is the 4th Day of July 1943).

The ordinator for numbers in German is the dot (“.”). Where German units are referred to in their original German designation, this practice has been followed. E.g. *14. Panzer-Division* is the German way of designating the 14th Armored Division.

The Germans normally referred to the large formations and the smallest units with an ordinator (i.e. armies, corps, divisions, brigades, and regimental battalions, as well as companies and platoons), whereas army groups, regiments and independent battalions were referred to in the reverse order. I.e. *Heeresgruppe Mitte, Artillerie-Regiment 103 (mot), or Panzer-Abteilung 33*. To facilitate the location of the various units and to present a uniform system of identification, all units have the identifying numbers indicated first in this work. Army groups, having names as opposed to numbers, have their designations indicated last.

Numbers in German can be confusing to Anglo-Saxons, as the decimal point becomes a decimal comma:

German: 10,5 English: 10.5 = (ten and a half)

Similarly, the comma used to separate thousands is also reversed:

German: 10.000 English: 10,000 = (ten thousand)

Where using German designations, the German practice has been followed (i.e.: *3,7cm Pak*). Otherwise, the English usage prevails: (i.e. 37mm anti-tank gun), using the millimeter system instead of the German WW II system based on centimeters.

Military motor vehicles and armored fighting vehicles (AFV) have a number behind them in brackets. This number refers to either the German model number (either *Kfz.* = *Kraftfahrzeug*, or to *Sd. Kfz.* = *Sonder Kraftfahrzeug*); or to the tonnage of the carrier. For civilian-type personnel and load carriers without a special number, the engine size or the weight classification is indicated instead. E.g.: truck (3-ton) refers to a cross-country (all-wheel-drive) load-carrier with a 3-ton load factor.

Truck (medium) refers to a civilian (rear-axle-driven) load carrier with a load factor of between 3 to 4.4 tons. Halftrack (7) refers to the 8-ton halftrack (*Zugkraftwagen*) with the *Sd.Kfz.* number 7. Car (2) refers to the light personnel carrier with the *Kfz.* number 2. Etc. Etc. The reader is referred to the sections on vehicles in the back of this book.

Van is a load carrier with a closed, hard body, (usually of wood), used for office and communications work. Truck is a load carrier having an open bed, which could be fitted with a tarpaulin stretched over tubular metal or wooden hoops.

The diagrams are based on reproductions of German organizational symbols of the period.

The text beneath each diagram has been used to clarify it, and to give details about composition and the amounts of sub-units. It breaks down the KStN, giving numbers and date of issue. KStN that are no longer available are marked thus: *)

The vehicles or items indicated behind the unit being described indicate the amounts in one of these units. E.g.:

3 Lt Tele Sect: 1 car (2), means that the three light telephone sections each have one light communications vehicle (*Kfz.* 2).

In some cases, sections do not have their own vehicles, or several sections share a vehicle. In these two cases, this is indicated in the text. E.g.:

1 Mortar Section: rides with one of the infantry squad's vehicles, or,
2 Pack Radio Sect: ride together in one truck (2-ton).

The designation “Trains” includes all the administrative, supply, rations, and baggage elements of the corresponding unit. Although maintenance sections and detachments were included under this designation, they have been presented separately for clarity.

In some cases, no vehicles are present. In this case, # Digits within brackets indicate: (# Officers – NCO – Enlisted Men).

TABLES OF ORGANIZATION – *KRIEGSTÄRKENACHWEISUNGEN*

German unit organizations were based on tables of organization, (*Kriegsstärkenachweisungen* - KStN). Every unit raised had them, and all orders raising units indicated the corresponding KStN numbers and dates which applied for them. These orders also indicated any modifications that might apply at the time.

The Germans did not necessarily issue their KStN on the dates indicated on them, and it is highly unlikely that units conformed to the KStN on their issue dates. The KStN could be distributed before or after (retroactively to) the issue date. The issue date merely referred to a specific deadline upon which the KStN was to become effective. On 24.09.1943, for example, new organizations for all Panzer and Panzergrenadier Divisions were ordered, although the new KStN were dated 1.11.1943 (and in a few cases 1.10.1943). Standard KStN were always dated on the 1st of the month. Provisional KStN were dated any other day of the month. These provisional KStN, (issued to test new organizations and changes to be promulgated), were then replaced by the official, standard KStN when ready. Sometimes, these provisional KStN remained in force and in effect became the standard KStN. In such cases, a “standard” KStN (with an issue date on the 1st of the month), was not issued at all.

As new KStN appeared, the old ones were supposed to be destroyed in the field. The bombing and the ensuing fire caused the destruction of the Potsdam military archives in 1945, which means that only portions of the KStN remain today.

KStN could be modified (changed) by General Army Memorandums (AHM – *Allgemeine Heeresmitteilungen*) and also by orders issued by the various arms inspectorates or higher headquarters. These agencies continually changed and modified the KStN, adding a vehicle here, deleting a soldier or three there, or making other modifications.

The KStN are identified by their original issue date in this book. Such changes as made by the orders mentioned above have been incorporated, but the dates of and authorizations for these changes have not been indicated.

The Germans occasionally published lists with valid KStN at specific periods, approximately once a year. Some of the KStN indicated on these lists were never published, or they were issued, but with a remark that they were not to be implemented until further notification, (or specific orders), which, in some cases, was never forthcoming. Some KStN existed only a short time, never appearing on these validity lists, (either cancelled, never authorized, or superseded).

Other KStN were issued twice under the same date with minor modifications. The validity of the second one was indicated by underlining the date. Any KStN issued on that date had to have the date underlined to be valid.

KStN and changes became valid when authorized by higher headquarters and then applied immediately to unit strength reports. Internal reorganizations of the units were not made until the indicated units were able to implement them. This might mean having to wait until the units could be withdrawn from combat and having time for training and administrative matters. Units to be issued with new and particularly complicated equipment were withdrawn to training grounds, transferring most of their old equipment to other units upon departure. A new unit was normally raised, trained, and equipped at one of the training grounds and then sent to the front, where normally (but not always immediately) it joined its parent unit or formation.

The SS headquarters issued SS KStN, the great majority without a number. They were identified and referred to by their nomenclature and date in orders and other correspondence.

The author has extrapolated the missing KStN from other KStN, which could be either contemporary and similar, or of the same KStN of later and/or earlier dates. The KStN number of the unit being defined in this case has an *) behind it. These educated guesses are also based on what information could be gleaned from orders of battle, unit histories (where available), unit strength reports, and German tactical doctrine manuals of the period.

It is important to emphasize that KStN indicated the maximum authorized organization. In many cases, they represented an ideal organization which in reality was not achieved.

GERMAN UNITS AND ORGANIZATIONAL SYMBOLS 1943

The symbols in this book are based on the official German handbook of military symbols (H.Dv. 272) of 23.05.1943, and on the actual symbols used in the organizational charts (Kriegsgliederungen des Feldheers, (1.07.43)). Where symbols in the latter are at variance with the former, the symbols of the organizational charts have been used.

The organizational unit symbols introduced in 1943 were simplified. E.g., antitank units now also used a representation of the basic antitank gun symbol itself; weapon symbols themselves were no longer modified, but had instead identifying information placed next to them, etc.

In German organizational charts (and, as reflected in this book), the headquarters symbol represents two purposes. First, it indicated the size, function, and mobility of the unit. And, second, it also indicated the headquarters of that echelon itself. I.e., there was no separate symbol for this echelon's headquarters. For all headquarters units with (and important units without) separate KStN, the corresponding symbols were placed to the right of the echelon's symbol. The same applied to those units that were directly assigned to the echelon's headquarters. For example, the signal and tank platoon of an armored regiment (although part of the Regiment Headquarters) were put next to the headquarters, but the independent tank maintenance platoon of a tank battalion was placed underneath it.

The different functions and mobility additions were used to enhance the echelon's symbol to indicate a specific purpose. Company-sized units and sub-units symbols were also modified in a similar fashion.

The Germans numbered their units on organizational charts from the right. I.e., the first company was on the far right, and the last company was on the far left.

An interesting feature of company and sub-unit symbols is that their size, shape, and dimensions could be altered to fit the diagram being depicted with them. Several infantry companies, for example, were placed side-by-side, elongated upwards, (so that all weapons symbols could fit within), and only the left-hand company had a thickened edge used to indicate its size (more of this below). The variations in size and shape followed the original configuration, and the basic symbol was still recognizable as such.

The symbols were intended to be mnemonic. The headquarters symbols reflected the units' pennants used on vehicles or the standards themselves. (These flags and pennants were of different colors to represent the various combat arms, and usually had a number, letter, and/or heraldic symbol superimposed upon them). Hence, any German looking at one of these symbols could immediately recognize the unit type being depicted. The colors in real life were substituted by the unit function and mobility modifiers above and below the symbols. In addition, a simplified version of the organizational symbols was, for example, painted on unit vehicles and used on maps.

The mobility of the unit was also quickly recognizable. For example, the two small circles ('wheels') underneath a symbols identified the unit as being motorized. In case these wheels were over the symbol (applied only to artillery-type units), this indicated that the unit was motorized by half-tracked prime movers. Elongated ovals ('tracks') applied underneath the symbol meant that the unit was either self-propelled or fully tracked.

The lozenge symbol represented armor. All tank-type units used this symbol, including assault artillery (Sturmgeschütz, Sturmhaubitze), as well as Sturmpanzer. It was shaped to reflect World War I tanks, and hence provided a good memory assist.

Aside from a very few specialized symbols, which were quickly memorized, all company-sized and smaller unit symbols tended to reflect the units' function or their main weapon. In most cases, a unit too difficult to depict easily was instead represented by a box with a corresponding abbreviation inside. In case it belonged to a particular arm, the arms symbol could be placed on top of or within this box. Where various modifiers applied, these were all added to the symbol.

Company-sized units had, somewhere within their symbol, a thickened part, usually a side.

Artillery Inspectorate firing batteries (tube, rocket-launcher, and Army anti-aircraft) batteries used the basic weapon symbols without thickening. A large weapon symbol (usually with the number of guns underneath) indicating a battery. (Firing artillery units smaller than battery size were depicted by smaller scale symbols). The caliber was indicated on the left of the symbol, (in centimeters or weight), and further identification, (if necessary), on the right. None-firing batteries followed the normal form of thickening a portion of the symbol to indicate their size.

The weapon symbols for the Infantry and Panzertruppen Inspectorate artillery-type companies (light and medium anti-aircraft, infantry gun) had the upright stems of the weapon symbols representing these types of companies thickened accordingly.

Where several columns, platoons, or detachments were gathered into a headquarters company or heavy company, these symbols were enclosed in a box with a thick side.

The units smaller than companies, whether independent or as sub-components, were usually depicted on organizational charts only if they had their own KStN. Exceptions occurred, particularly if the headquarters sub-units contained specialized equipment.

Staffel (Detachment) This was an elastic designation for several components under a headquarters section, these components being from section to platoon size. Often this was merely an administrative grouping, and the components were distributed to other sub-units in combat. It could either have its own small headquarters section, or one of the components' leaders could carry out a dual function.

Kolonne (Column) This was an independent transportation unit, varying from company to platoon size, transporting equipment or supplies such as a bridge column (which in fact did not actually built the bridge it was transporting), or even as an 'infantry' column (which consisted of a set number of horse-drawn vehicles capable of transporting a fixed tonnage).

Zug (Platoon) Independent unit or the typical main subdivision of companies and batteries. Usually, the 1st and 2nd platoons in each company-sized unit, and also of independent platoons, were lead by a lieutenant, while the other platoons were headed by a senior NCO.

Trupp (lit. Troop; Section) A small unit, equipped with specialized equipment; it could also function as a headquarters unit.

The units indicated below were not depicted as separate symbols.

Halb-Zug (lit.: Half-Platoon) Some platoons, for example HMG Platoons, could be divided into two parts.

Gruppe (Squad, Section) Normally the smallest sub-unit that existed in the German Army. In this book, the word "Squad" has only been used for infantry and reconnaissance infantry units. All other units of this size have been designated as "Sections".

Halb-Gruppe (lit. Half-Squad, i.e. Team) Infantry and reconnaissance squads could be broken down into two parts. Infantry and reconnaissance squads were built up around the squad LMG. Where only one LMG was provided, one team provided cover while the other team was the movement element. Where two LMG were available, the teams covered each other in turns. Reconnaissance teams, on the other hand, were trained to work independently, although they too could function as a squad.

GERMAN ORGANIZATIONAL SYMBOLS
1943

SIZE, FUNCTION, MOBILITY

General Headquarters	Army Group Headquarters	Army Headquarters	Group Headquarters	Corps Headquarters	Military Commander	Division Headquarters	Brigade Headquarters	Regiment Headquarters	Battalion Headquarters	Company Headquarters	Band
Infantry	Reconnaissance	Signal	Engineer	Bridging Engineer	Railroad Engineer	Technical	Supply	Motor Transport	Maintenance	Medical	Veterinary
Infantry	Mountain	Bicycle	Semi-Motorized	Motorized	Motorcycle	Armored Infantry	Panzer Div. Tank	Anti-Tank	Construction	Military Police	Cavalry
Artillery	Mountain Artillery	Self-Propelled Artillery	Panzer Div. Artillery	Artillery Observation	Rocket Artillery	Recoilless Artillery	Assault Artillery	Infantry Anti-Aircraft	Army Anti-Aircraft	Luftwaffe Anti-Aircraft	Machine Gun
Foot / Horse-Drawn	Mountain	Ski or Sled	Bicycle	Mixed Mobility	Semi-Motorized	Motorized	Motorcycle	Halftrack Towed	Amphibious Motorized	Self-Propelled (Tracked)	Armored Halftrack

WEAPONS

Weapon												
		Machine Gun	Anti-Tank Rifle	Infantry Gun	Mortar	Anti-Tank Gun	Rocket Launcher	Gun	Howitzer	Heavy Howitzer	Anti-Aircraft Gun	Flame Thrower
light	<i>le</i>	with bipod	to 79mm	to 75mm	to 79mm	to 39mm	to 109mm	to 99mm	to 129mm		to 36mm	man-packed
medium	<i>m</i>				80 - 119mm	40 - 59mm	110 - 159mm				37 - 59mm	
heavy	<i>s</i>	with tripod	over 80mm	over 76mm	over 120mm	60 - 89mm	160 - 219mm	100 - 209mm	130 - 209mm	210 - 249mm	60 - 159mm	vehicle-borne
super heavy	<i>sw</i>	over 15mm				over 90mm	over 220mm	over 210mm	over 210mm	over 250mm	over 160mm	

INFANTRY INSPECTORATE UNITS

















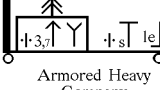







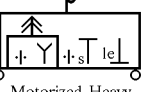







Infantry Platoon	Infantry Company	Infantry Mortar Company	Infantry Machine Gun Company	Infantry Engineer Platoon	Infantry Anti-Tank Platoon	Infantry Anti-Tank Company	Infantry Gun Platoon	Infantry Gun Company	Infantry Bicycle Platoon	Infantry Bicycle Company	Light Anti-Aircraft Co. (mot)
Mountain Infantry Platoon	Mountain Infantry Company	Mountain Mortar Platoon	Mountain Machine Gun Company	Mountain Engineer Platoon	Mountain Anti-Tank Platoon	Mountain Anti-Tank Company		Mountain Infantry Gun Company	Mountain Bicycle Inf. Plt.	Lt. Mountain Transport Column	Light Anti-Aircraft Co. (SP'd)
Cavalry Platoon	Cavalry Company	Cavalry Mortar Platoon	Cavalry Machine Gun Company	Cavalry Engineer Platoon	Cavalry Anti-Tank Platoon	Cavalry Inf. Gun Platoon	Infantry Mounted Recon. Plt.	Jäger	Machine Gun Company (motorized)	Mortar Company (motorized)	Medium Anti-Aircraft Co. (SP'd)

ENGINEER INSPECTORATE UNITS





























































Engineer Platoon	Engineer Company	Mountain Engineer Company	Motorized Engineer Company	Armored Engineer Company	Engineer Goliath	Engineer Assault Boat Company	Bridge Construction Company	Construction Company	Road Construction Company	Engineer Equipment Plt. (mot)	Railroad Engineer Company
Bridge Column B (motorized)	Bridge Column K (motorized)	Bridge Column J (motorized)	Unit of Bridge Equipment H	Unit of Bridge Equipment leZ	Unit of Bridge Equipment sS	Bridge Unit with Escort Detachment	Bridge Column Unit & Escort Detachment	Engineer Snow-Clearing Plt. (mot)	Light Engineer Transport Column (mot)	Engineer Park	Railroad Engineer Park

GERMAN ORGANIZATIONAL SYMBOLS
1943













PANZERTRUPPEN INSPECTORATE UNITS

 Motorized Infantry Platoon	 Motorized Infantry Company	 Motorized Heavy Company (typical example)	 Armored Infantry Platoon	 Armored Infantry Company	 Armored Flamethrower Platoon	 Armored Gun Platoon	 Armored Heavy Company (typical example)	 Motorized Inf. Gun Company	 Self-Propelled Inf. Gun Company		
 Motorcycle Recon. Platoon	 Motorcycle Recon. Company	 Kettenrad Recon. Company	 Volkswagen Recon. Company	 Armored Recon. Company	 Motorized Heavy Reconnaissance Company (typical example)	 Armored Car Platoon	 Armored Car Company (wheeled)	 Armored Car Company (half-tracked)	 Armored Car Company (tracked)	 Light Recon. Transport Column	
 Tank Platoon	 Tank Company	 Radio-Controlled Tank Co.	 Tank (Sturmgeschütz) Company	 Assault Tank Company (Sturmpanzer)	 Armored Headquarters Company	 Tank Maintenance Platoon	 Tank Maintenance Company	 Flame Tank Platoon	 Motorized Anti-Tank Company	 Self-Propelled Anti-Tank Company	 Light Panzer Transport Column





































ARTILLERY INSPECTORATE UNITS

 Light Field Gun Battery	 75mm Mtn. Gun Battery (GK 15)	 75mm Field Gun Battery (FK 16nA)	 75mm Cav. Gun Battery (FK 16nA)	 75mm Field Gun Battery (FK 18)	 Assault Gun Battery (Sturmgeschütz)	 Light Field Howitzer Battery	 105mm Field Howitzer Bty. (le. FH 16)	 105mm Field Howitzer Bty. (le. FH 18)	 Heavy Field Howitzer Battery	 150mm Field Howitzer Bty. (s. lg. FH 13)	 150mm Field Howitzer Bty. (sFH 18)
 Heavy Gun Battery	 105mm Gun Battery (K 17)	 105mm Gun Battery (K 18)	 150mm Gun Battery (K 16)	 150mm Gun Battery (K 18)	 150mm Gun Battery (K 39)	 150mm Gun Battery (How. Base)	 170mm Gun Battery (How. Base)	 210mm Gun Battery (K 12)	 210mm Gun Battery (K 38)	 210mm Gun Battery (K 39)	 240mm Gun Battery (K 3)
 240mm Howitzer Bty. (H 39)	 210mm Howitzer Bty. (lange Mörser)	 210mm Howitzer Bty. (M 18)	 305mm Howitzer Battery	 355mm Howitzer Bty. (M 1)	 600mm Howitzer Bty. (Karl Gerät)	 75mm Recoilless Bty. (LG 1)	 105mm Recoilless Bty. (LG 2)	 Army AA Searchlight Battery	 20mm Flak Army AA Battery	 37mm Flak Army AA Battery	 88mm Flak Army AA Battery
 105mm Rocket Launcher Bty. (Nb. W. 40)	 150mm Rocket Launcher Bty. (Nb. W. 41)	 210mm Rocket Launcher Bty. (Nb. W. 42)	 280/320mm RL Bty. (Nb. W. 41)	 300mm Rocket Launcher Bty. (Nb. W. 42)	 Motorized Headquarters Battery	 Hqs. Bty. Self-Propelled Battalion	 Hqs. Bty. Assault Gun Battalion	 Hqs. Bty. Army AA Battalion	 Hqs. Bty. Rocket Battalion	 Hqs. Bty. Art. Obs. Battalion	 Artillery Park
 Motorized Calibration Detachment	 Mountain Calibration Detachment	 Calibration Platoon	 Calibration Battery	 Weather Detachment	 Motorized Weather Platoon	 Sound-Ranging Battery	 Flash-Ranging Battery	 Motorized Balloon Platoon	 Artillery Transport Column (mot)	 Army AA Transport Column (mot)	 Rocket Transport Column (mot)

SIGNAL INSPECTORATE UNITS

 Motorized Propaganda Company	 Motorized Signal Company	 Motorized Telephone Company	 Mountain Telephone Company	 Telephone Construction Company	 Wire Construction Company	 Telephone Operations Company	 Motorized Radio Company	 Motorized Interception Company	 Armored Signal Company	 Armored Radio Company	 Light Signal Transport Column (mot)
---	---	--	---	---	--	---	--	---	---	--	--

REAR ECHELON UNITS

 Horse-Drawn Transport Column (15t)	 Horse-Drawn Transport Column (30t)	 Horse-Drawn Transport Column (60t)	 Motorized Transport Column (30t)	 Motorized Transport Column (60t)	 Motorized Transport Company (90t)	 Motorized Transport Company (120t)	 Motorized Light Supply Company	 Motorized Heavy Supply Company	 Motorized P.O.L. Col. (25cbm)	 Motorized P.O.L. Col. (50cbm)	 Motorized Water Tanker Col. (60cbm)
 Motorized Bakery Company	 Motorized Butchery Company	 Mot. Rations Administration Detachment	 Motorized Field Post Detachment	 Motorized Military Police Platoon	 Motorized Military Police Company	 Motorized Trains	 Field Hospital	 Medical Company	 Motorized Ambulance Platoon	 Veterinary Company	 Mot. Horse Transport Column
 Motorcycle Messenger Platoon	 Motorized Maintenance Platoon	 Motorized Maintenance Company	 Motorized Armorer Company	 Motorized Spare Parts Detachment	 Motorized Spare Parts Column	 Motorized Recovery Platoon	 Tank Recovery Platoon	 Motorized Mapping Detachment	 Motorized Printing Detachment	 Motorized Printing Platoon	 Motorized Technical Company



<i>Abbr.</i>	<i>German</i>	<i>English</i>	<i>Abbr.</i>	<i>German</i>	<i>English</i>
AA	–	anti-aircraft	lg	lang	long
Abt	Abteilung	Battalion	Li	Lichtmess	flash ranging
AC	–	armored car	LMG	–	light machine gun
AG	–	Army Group	lt	–	light
Ammo	–	ammunition	Lw	Luftwaffe	German Air Force
Armd	–	armored	M, Mörs	Mörser	howitzer
–	Armee	Army	m	mittler	medium
–	Armeeabteilung	Army-sized Command	MB	Militärbefehlshaber	Army Military Commander
AT	–	antitank	mcl	–	motorcycle
ATG	–	antitank gun	mcl w/sc	–	motorcycle with side car
ATR	–	antitank rifle	med	–	medium
Arko	Artillerie Kommandeur	Artillery Commander	MG	Maschinengewehr	machine gun
Battr	Batterie	Battery	mot	motorisiert	motorized
Befh	Befehlshaber	Commander	mot S	mot. Selbstfahrlafette	self-propelled carriage
–	Befehlshaber rückwärtiges Heeresgebiet	Commander of Army Group Rear Area	Nbl	Nebel	smoke
Btl, Batl	Bataillon	Battalion	Nbl W	Nebelwerfer	rocket launcher
Bb, Beob	Beobachtung	observation	NCO	–	Non-Commissioned Officer
Bn	–	Battalion	Ob.	Oberbefehlshaber	Commander-in-Chief
bo	bodenständig	static	Off	–	Officer
Brig	Brigade	Brigade	OKH	Oberkommando des Heeres	Army High Command
Bty	–	Battery	OKW	Oberkommando der Wehrmacht	Armed Forces High Command
Bulg	–	Bulgarian	ops	–	operations
cc	–	cross-country	(p)	polnisch	Polish
CE	–	Combat Engineer	Pak	Panzerabwehrkanone	antitank gun
Ch H Rüst	Chef Heeresrüstung und u. BdE	Chief of Army Equipment and Commander of the Reserve Army	Pi, Pion	Pionier	(Combat) Engineer
Co	–	Company	Plt	–	Platoon
Col	–	Column	Pol	Polizei	police
Det	–	Detachment	P.O.L.	–	petrol, oil, lubricants
Div	Division	Division	Prop	Propaganda	propaganda
EM	–	Enlisted Man	Pz, Panz	Panzer	tank, armor
Engr	–	Engineer	Pz-Bef	Panzerbefehlswagen	command tank
(f), (fr)	französisch	French	PzGren	Panzergrenadier	motorized infantry
F.A.D.	Feldausbildungsdivision	Field Training Division	PzGren (gp)	Panzergrenadier (gp)	armored infantry
FEB	Feldersatz-Bataillon	field replacement battalion	(r)	russisch	Russian
Fest.	Festung	Fortress	Recon	–	reconnaissance
FH	Feldhaubitze	field howitzer	Res	Reserve	reserve
FK	Feldkanone	field gun	RF-SS	Reichsführer-SS	Reichs Leader of the SS
Fla	Flugabwehr	anti-aircraft	Rgt	Regiment	Regiment
Flak	Flugabwehrkanone	anti-aircraft gun	RL	–	rocket launcher
Fkl	Funklenk	radio-controlled	RSO	Raupenschlepper Ost	fully-tracked load carrier
FL	Feuerleit	artillery fire control	Rum	–	Rumanian
Füs	Füsilier	Infantry	s, schw	schwer	heavy
Fs	Fallschirm-	Parachute / Airborne	Sch	Schallmess	sound ranging
G, Gesch	Geschütz	gun, cannon	Schn	Schnelle	mobile
Geb.	Gebirgs-	mountain	Sd	sonder	special
GHQ	–	General Headquarters	Sd Kfz	Sonder-Kraftfahrzeug	special military vehicle
GK	Gebirgskanone	mountain gun	Sec	–	Security
GSO	(Beamte)	Government Service Official	Sect	–	Section
gp, gep	gepanzert	armored	Sf	selbstfahrlafette	self-propelled
Gr	Gruppe	Group / Force	Sfl	Selbstfahrlafette	self-propelled carriage
Gren	Grenadier	Infantry	Sich	Sicherheits-	security
H, Haub	Haubitze	(gun-) howitzer	Slov.	–	Slovakian
Harko	Höhere Artillerie Kommandeur	Higher Artillery Commander	SMG	–	sub machine gun
HMG	–	heavy machine gun	SP, SP'd	–	self-propelled
Hqs	–	headquarters	SPW	Schützenpanzerwagen	armored personnel carrier
hvy	–	heavy	Sdq	–	Squad
–	Hun.	Hungarian	Sqdn	–	Squadron
IG	Infanterie-Geschütze	infantry gun	SS	Waffen-SS	Nazi Party military arm
I, Inf	Infanterie	Infantry	ss, sw	schwerste	super heavy
–	Ital.	Italian	St, Stb	Stab	headquarters
Jg	Jäger-	Light Infantry	–	Sturm-	assault
K, Kan	Kanone	gun	StuGesch	Sturmgeschütz	assault gun (SP'd)
Kdo	Kommando	command	StuHaub	Sturmhaubitze	assault howitzer (SP'd)
KK	Kettenkrad	0.5-ton halftrack (aka: halftracked motorcycle)	StuPz	Sturmpanzer	assault tank (armored heavy IG)
kl	klein	small, light	(t)	tschechisch	Czechoslovakian
Kol	Kolonne	Column	tele	–	Telephone
Kp	Kompanie	Company	VW	Volkswagen	light cross-country car
KStN	Kriegstärkenachweisung	Table of Organization	Versorg	Versorgungs-	support
kz	kurz	short	w/	–	with
l, le, lei	leicht	light	w/o	–	without
LG	Leichtgeschütz	recoilless gun	WB	Wehrmachtsbefehlshaber	Armed Forces Military Commander
			Wfr	Werfer	(rocket-, grenade-) launcher
			WK	Wehrkreis	Military District
			zbV	zur besonderer Verwendung	for special (purposes / use)
			Zug	–	Platoon or railroad train

ORDER OF BATTLE

ARMY GROUP NORTH 18. Pz-Gr. Div. 223. Inf. Div. 388. F.A.D.	16. Armee	II. Korps	331. Inf. Div. 12. Inf. Div. 218. Inf. Div. 123. Inf. Div. 93. Inf. Div.	ARMY GROUP A 13. Pz. Div.	Befh. der Krim	Rum. Mountain Corps	Rum. 4 Mm. Div. Rum. 2 Mm. Div.	ARMY GROUP D (Ob. West)	WB Niederlande	LXXXVIII. Korps	346. Inf. Div. 16. Lw.Feld-Div. 719. Inf. Div.				
		Gruppe Höhe (VIII)	21. Lw.Feld-Div. 122. Inf. Div. 32. Inf. Div.			Kommando Auleb	153. F.A.D. Slov. Mobile Div. 355. Inf. Div. 381. F.A.D.		15. Armee	LXXXIX. Korps	19. Lw.Feld-Div. 712. Inf. Div. 171. Res. Div.				
		X. Korps	5. Jg. Div. 30. Inf. Div. 8. Jg. Div. 126. Inf. Div. 329. Inf. Div.			Befh. Straße Kertsch	5. Lw.Feld-Div.		44. Inf. Div. 65. Inf. Div. 305. Inf. Div. 24. Pz. Div. 9. SS-Div.	LXXII. Korps	18. Lw.Feld-Div. 156. Res. Div. 191. Res. Div.				
	18. Armee 121. Inf. Div. 28. Jg. Div.	XXXVIII. Korps	1. Lw.Feld-Div. 717. Inf. Div. SS Lett. Brig.		17. Armee	Gr. Almendinger	Rum. 9 Cav. Div. Rum. 19 Inf. Div. Rum. 6 Cav. Div. 4. Geb. Div. Rum. 1 Mm. Div. 73. Inf. Div. 9. Inf. Div.		XI. Flieger Korps 1. Fs-Jg. Div. 2. Fs-Jg. Div.	LXXXIV. Korps	76. Inf. Div. 94. Inf. Div. 113. Inf. Div. 371. Inf. Div. 389. Inf. Div.	LXXXVII. Korps	348. Inf. Div. 17. Lw.Feld-Div. 711. Inf. Div.		
		L. Korps	13. Lw.Feld-Div. 227. Inf. Div.				XXXIV. Korps			97. Jg. Div. 70. Inf. Div. 101. Jg. Div. Rum. 19 Inf. Div. 79. Inf. Div. Rum. 10 Inf. Div. 98. Inf. Div. 125. Inf. Div.	LXXXV. Korps	716. Inf. Div. 709. Inf. Div. 319. Inf. Div.			
		XXVII. Korps	96. Inf. Div. 61. Inf. Div. 81. Inf. Div. 12. Lw.Feld-Div. 225. Inf. Div. 132. Inf. Div.				XXXIX. Gebirgs-Korps			370. Inf. Div. 50. Inf. Div. 125. Inf. Div. Rum. 3 Mm. Div.	LXXXVI. Korps	348. Inf. Div.			
		XXXVI. Korps	212. Inf. Div. 1. Inf. Div. 11. Inf. Div. 69. Inf. Div. 290. Inf. Div. 23. Inf. Div. 5. Geb. Div.				Befehlshaber rückwärtiges Heeresgebiet A			LXXXVII. Korps	158. Res. Div. 708. Inf. Div.				
		LIV. Korps	21. Inf. Div. 24. Inf. Div. 254. Inf. Div. SS Polizei-Div. 58. Inf. Div.				ARMY GROUP CENTER Gr. Eisebeck 4. Pz. Div. 12. Pz. Div. 10. Pz-Gr. Div. 5. Pz. Div. 8.Pz. Div. 36. Inf. Div. 83. Inf. Div. 390. F.A.D. 391. F.A.D. 201. Sich. Div. Hun 1 Lt. Div.			2. Armee	VII. Korps	68. Inf. Div. 75. Inf. Div. 26. Inf. Div. 323. Inf. Div. 88. Inf. Div.	Div. Rhodos	LXXXVIII. Korps	326. Inf. Div. 388. Inf. Div. 356. Inf. Div. 715. Inf. Div.
		L. Korps	250. Inf. Div. 170. Inf. Div. 215. Inf. Div.							XIII. Korps	327. Inf. Div. 340. Inf. Div. 377. Inf. Div. 82. Inf. Div.	Befh. Kroatien		100. Jg. Div. 114. Jg. Div. 118. Jg. Div. SS Eugen Div. 369. Inf. Div. 373. Inf. Div. 187. Res. Div.	
	III. Lw. Feldkorps	9. Lw.Feld-Div. 10. Lw.Feld-Div.	9. Armee		XX. Korps	251. Inf. Div. 45. Inf. Div. 137. Inf. Div. 72. Inf. Div.			Befh. Serbien	297. Inf. Div. Bulg. 7 Inf. Div. Bulg. 9 Inf. Div. Bulg. 21 Inf. Div.					
Befehlshaber rückwärtiges Heeresgebiet Nord		207. Sich. Div. 281. Sich. Div. 285. Sich. Div.	XXXVI. Pz. Korps	102. Inf. Div. 258. Inf. Div. Gr. Manteuffel 7. Inf. Div. 31. Inf. Div.	Befh. Saloniki-Ägäis	1. Geb. Div.									
ARMY GROUP SOUTH Rum 24 Inf. Div. 16. Pz-Gr. Div.	6. Armee	XXIX. Korps	111. Inf. Div. 15. Lw.Feld-Div. 17. Inf. Div. 336. Inf. Div.	XXXVII. Pz. Korps	20. Pz. Div. 2. Pz. Div. 6. Inf. Div. 9. Pz. Div.	Befh. Süd-griechenland		11. Lw.Feld-Div. 104. Jg. Div.							
		XVII. Korps	294. Inf. Div. 306. Inf. Div. 302. Inf. Div.	XXXVIII. Pz. Korps	18. Pz. Div. 292. Inf. Div. 86. Inf. Div.	LXXXIII. Korps		1. Pz. Div. 117. Jg. Div.							
		Gruppe Mieth (IV.)	304. Inf. Div. 3. Geb. Div. 335. Inf. Div.	XXXIX. Pz. Korps	78. Sturm-Div. 216. Inf. Div. 383. Inf. Div.	Festung Kreta	Fest. Brig. Kreta 22. Inf. Div. (LL) Ital. Stenna Div.								
	1. Panzer-Armee	XXX. Korps	62. Inf. Div. 38. Inf. Div. 287. Inf. Div.	XXXXI. Pz. Korps	134. Inf. Div. 110. Inf. Div. 296. Inf. Div. 339. Inf. Div.	Ob. Süd (Commando Supremo)	XIV. Pz. Korps	Lw. HG Pz. Div. 16. Pz. Div. 29. Pz-Gr. Div. Brig. RF-SS 15. Pz. Div. 90. Pz-Gr. Div. 3. Pz-Gr. Div.							
		XXXX. Pz. Korps	333. Inf. Div. 46. Inf. Div. 257. Inf. Div.	XXXXV. Korps	299. Inf. Div. 56. Inf. Div. 262. Inf. Div. 34. Inf. Div.		20. Geb. Armee	XVIII. Geb. Korps	SS Nord Div. 7. Geb. Div. 18. Geb. Pol. Rgt.						
		LVII. Pz. Korps	15. Inf. Div. 198. Inf. Div. 328. Inf. Div.	LIII. Korps	208. Inf. Div. 25. Pz-Gr. Div. 211. Inf. Div. 293. Inf. Div.			XXXVI. Geb. Korps	169. Inf. Div. 163. Inf. Div.						
		XXIV. Pz. Korps	23. Pz. Div. 17. Pz. Div. SS W-Div.	LV. Korps	131. Inf. Div. 14. Inf. Div. 321. Inf. Div.			XIX. Geb. Korps	2. Geb. Div. 388. Gren. Rgt. 6. Geb. Div. 139. Geb. Jg. Rgt. 210. Inf. Div. 503. Lw. Feld-Rgt. 193. Gren. Rgt.						
	Armee-abteilung Kampf	XXXXII. Korps	161. Inf. Div. 39. Inf. Div. 282. Inf. Div.	4. Armee 183. Inf. Div. 253. Inf. Div.	LVI. Pz. Korps	267. Inf. Div. 260. Inf. Div. 268. Inf. Div.		Norwegen Armee (WB Norwegen)	LXXI. Korps	230. Inf. Div. 270. Inf. Div. 199. Inf. Div.					
		Gruppe Raus (XI)	320. Inf. Div. 106. Inf. Div.		XII. Korps	342. Inf. Div. 252. Inf. Div. 35. Inf. Div.	XXXIII. Korps		14. Lw.Feld-Div. 702. Inf. Div. 181. Inf. Div.						
		III. Pz. Korps	7. Pz. Div. 19. Pz. Div. 6. Pz. Div. 168. Inf. Div.		IX. Korps	337. Inf. Div. 95. Inf. Div. 129. Inf. Div.	LXX. Korps		269. Inf. Div. 280. Inf. Div. 214. Inf. Div. 710. Inf. Div.						
4. Panzer-Armee	II. SS-Pz. Korps	SS T-Div. SS DR-Div. LSS AH-Div.	3. Panzer-Armee	XXXIX. Pz. Korps	246. Inf. Div. 197. Inf. Div. 256. Inf. Div. 52. Inf. Div.	196. Inf. Div. 274. Inf. Div. 25. Pz. Div.	Befh. Dänemark	416. Inf. Div. 71. Inf. Div. 20. Lw.Feld-Div.							
	XXXXVIII. Pz. Korps	167. Inf. Div. 11. Pz. Div. 3. Pz. Div. GD Pz-Gr. Div.		XXVII. Korps	206. Inf. Div. 330. Inf. Div. 87. Inf. Div.		III. SS-Pz. Korps	265. Inf. Div. 266. Inf. Div. 295. Inf. Div.							
	LII. Korps	332. Inf. Div. 255. Inf. Div. 57. Inf. Div.		VI. Korps	4. Lw.Feld-Div. 3. Lw.Feld-Div. 6. Lw.Feld-Div. 2. Lw.Feld-Div.		WB Ukraine	LXII. Res. Kdo. VIIth Hungarian Corps Hun. 18 Lt. Div. Hun. 21 Lt. Div. Hun. 24 Lt. Div. Hun. 25 Lt. Div.							
Befehlshaber rückwärtiges Heeresgebiet Süd		213. Sich. Div. 454. Sich. Div. 444. Sich. Div.	Befehlshaber rückwärtiges Heeresgebiet Mitte		286. Sich. Div. 221. Sich. Div. 203. Sich. Div.	WB Ostland	LXI. Res. Kdo. VIIIth Hungarian Corps Hun. 2 Lt. Div. Hun. 5 Lt. Div. Hun. 8 Lt. Div. Hun. 201 Lt. Div.								

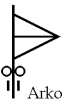

SS-Panzerkorps

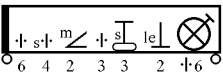
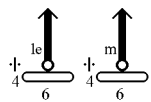
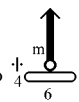

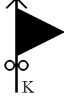

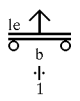
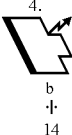
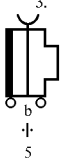
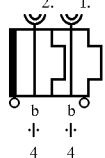
Arko      





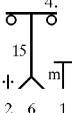
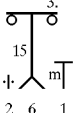
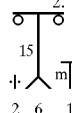
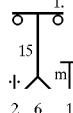

 

    

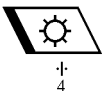
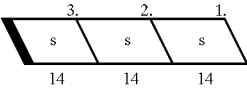





 



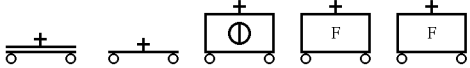





STAB, SS-PANZERKORPS
Headquarters, SS-Panzer Corps

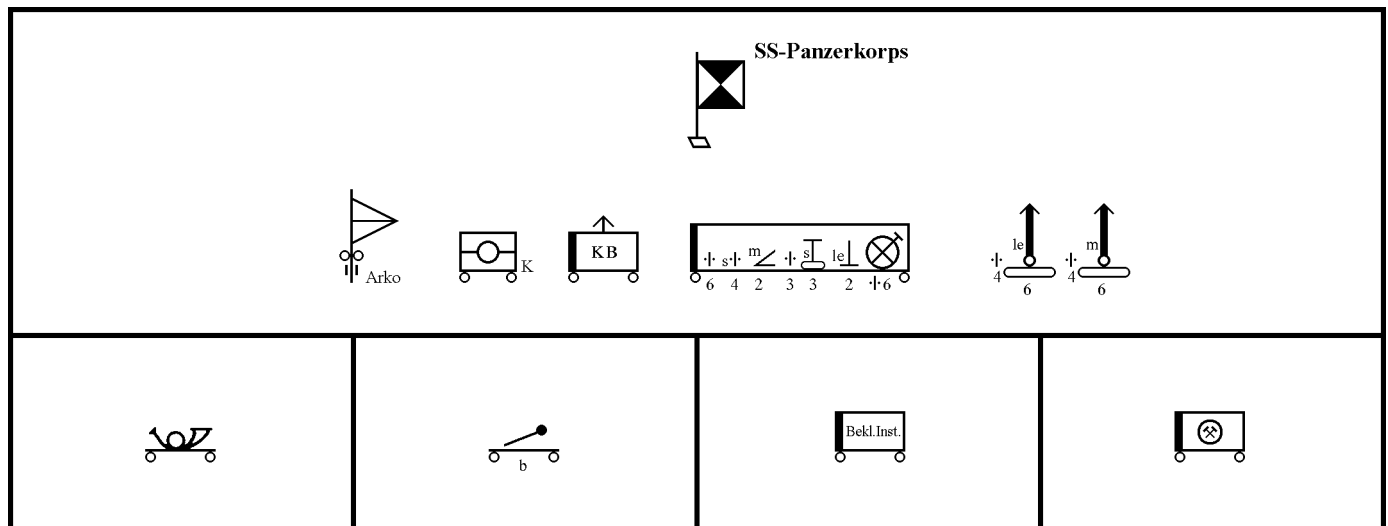

KStN 15
1.03.1942

Headquarters, Panzer Corps

Corps Commander & Chief of Staff
Corps Headquarters

Weapon Staff Officers

Staff Officer for Gas Protection
Engineer Staff Officer

Corps Administrative Department

Deputy Chief of Staff (*O.Qu.*)

Motor Vehicle Officer

Corps Intendant (*IVa*)

Corps Physician (*IVb*)

Corps Engineer (*V*)

Political Education Officer (*VI*)

Office of the Adjutant

Adjutant (*IIa*)

Main Records and Files Office

Provost Marshal (*III*)

Headquarters Commandant (*H.Qu.*)

Office of the Commandant: 3 mcl w/sc.

Paymaster General (*IVz*)

Commissary Officer

Corps Motor Pool

Motor Vehicle Detachment: 18 cars (medium); 2 cars (heavy); 4 cars (12); 2 cars (21); 6 trucks (2-ton); 9 trucks (medium); 1 truck (3-ton); 1 truck (heavy); 1 ambulance (31); 4 motor buses (2 converted to office use).

Motorcycle Detachment: 31 mcl; 5 mcl w/sc.

Maintenance Section: 1 mcl w/sc; 1 car (2/40).

Headquarters Guards: 1 infantry squad (# 0-0-3-12) with 4 LMG.

Command	Signal Battalion	Tank Battalion	Rocket Battalion	Supply Command	Medical Battalion	Notes	Commander
I. SS-Pz.Korps	101	101	101	101	101	[1]	SS-Obergruppenführer Joesf Dietrich (appointed 27.03.1943)
II. SS-Pz.Korps	102	102	102	102	102	[2]	SS-Obergruppenführer Paul Hassler
III. SS-Pz.Korps	103	103	103	103	103	[3]	SS-Obergruppenführer Felix Steiner
IV. SS-Pz.Korps	104	104	104	104	104	[4]	SS-Obergruppenführer Alfred Wünnenberg (appointed 05.08.1943)

[1] The I. SS-Pz.Korps "Leibstandarte" raised 27.07.43, initially planned as the headquarters for:

- SS-Division "Leibstandarte SS Adolf Hitler" (later 1. SS-Panzer Division),
- SS-Division "Hitlerjugend" (later 12. SS-Panzer-Division).

Organization: no geologist company; two ambulance platoons; two military police platoons, (in fact, it was planned to raise a military police company, KStN 2035, but with five instead of three platoons).

[2] The II. SS-Pz.Korps was the former SS-Panzerkorps of Charkov fame. (It is not clear why the first corps to be raised should be given the number 2). Initially, it was planned to command:

- SS-Division "Das Reich" (later 2. SS-Panzer-Division),
- SS-Division "Totenkopf" (later 3. SS-Panzer-Division).

Organization: additional rocket battery, equipped with the experimental 8cm launchers; missing clothing repair company.

[3] The III. SS-Pz.Korps "Germanisch" raised 15.04.43 for:

- SS-Division "Wiking" (later 5. Panzer-Division),
- SS-Division "Nordland" (later 11. SS-Panzergrenadier-Division),
- SS-Brigade "Nederland" (later 23. SS-Panzergrenadier-Brigade).

Organization: no Arko; only one field hospital.

[4] The IV. SS-Pz.Korps was raised on 05.08.43 by order of Hitler dated 01.06.43, initially to command:

- SS-Division "Hohenstaufen" (later 9. Panzer-Division),
- SS-Division "Reichsführer-SS" (later 16. SS-Panzergrenadier-Division).

Organization: no geologist company; two ambulance platoons. The heavy tank battalion and the rocket launcher battalion were to be raised later, (initially date was set for 01.04.44). Formation of the corps was not finished, the headquarters staff was used to form the VI. SS Corps in October 1943.

SS-PANZERKORPS
SS-Panzer Corps

KStN 2075 * 1.04.1942	Motorized Corps Map Detachment Det: 2 mcl; 2 cars (1); 1 bus (light/15 seats); 2 vans (medium); 1 trailer (generator).
SS KStN 1.01.1943	Motorized War Correspondent Company [1] 2 Plt: 4 cars (light-cc); 8 cars (medium); 1 film equipment van; 1 loudspeaker van; 2 recording equipment vans (17); 1 truck (light); 4 trucks (medium).
KStN 25 * 1.02.1941	Headquarters, Motorized Artillery Command (Arko) Hqs: 5 mcl; 3 cars (1); 3 cars (15); 1 bus (light/15 seats); 1 van (3-ton).
KStN 1121 1.11.1941	Corps Escort Company Company Headquarters: Hqs Sect: 3 mcl; 2 mcl w/sc; 1 car (15). Lt Tele Sect c: 1 car (15). Maint Sect: 1 mcl w/sc; 1 car (2/40). Co Trains: 1 car (15); 1 truck (2-ton); 1 truck (medium); 1 truck (3-ton).
ex KStN 1153 1.11.1941	Motorcycle Plt: Hqs Sect: 3 mcl; 2 cars (15). 2 Sqd: 4 mcl w/sc; 1 Scout Squad w/ 2 LMG.
KStN 1123 1.11.1941	Infantry Gun Plt: Hqs Sect: 1 mcl; 1 mcl w/sc; 1 truck (69). Gun Sect: 3 trucks (69); 2 Lt IG (75mm – towed); 1 trailer (ammo).
ex- KStN 1148a * 1.12.1942	Antitank Plt: Hqs Sect: 1 mcl; 1 mcl w/sc; 1 car (1); 2 Maultier (3). Gun Sect: 3 ATG (76.2mm or 75mm); 3 LMG.
ex- KStN 162 1.02.1941	Machine Gun Plt: Hqs Sect: 1 mcl w/sc; 2 cars (15). 2 MG Sect: 1 truck (medium); 2 HMG. 1 Mortar Sect: 1 car (11); 2 trucks (medium); 2 mortars (81mm).
ex- KStN 138c 1.11.1941	Infantry Plt: Hqs Sect: 1 mcl; 2 LMG (equipment reserve); personnel ride in Infantry Squad trucks. 4 Inf Sqd: 1 truck (medium); 1 Infantry Squad with 1 LMG.
KStN 198 1.02.1941 (modified)	Self-Propelled Medium Anti-Aircraft Company [2] Co Hqs: 2 mcl; 1 car (medium); 1 car (12). Signal Det: Hqs Sect: 1 car (2). 1 Lt Tele Sect c: 1 car (15). 5 Pack Radio Sect b: 1 car (2). 2 Med AA Plt: Hqs Sect: 3 mcl; 1 car (15). Gun Sect: 3 halftracks (6/2 with 37mm Flak); 1 truck (3-ton); 1 LMG.
ex- KStN 192 1.02.1941	2 Lt AA Plt: Hqs Sect: 4 mcl; 1 car (15). Ammo Sect: 2 halftracks (10/4 without guns). Gun Sect: 3 halftracks (10/4 with 20mm Flak 38). Ammo Det: 3 trucks (3-ton). Co Maint Sect: 1 mcl w/sc; 1 car (2/40); 1 truck (medium). Co Trains: 3 mcl; 1 mcl w/sc; 1 car (15); 2 trucks (light); 2 trucks (1½-ton); 3 trucks (3-ton).
KStN 2033b 1.03.1942	Motorized Corps Military Police Detachment Det: 12 mcl; 4 mcl w/sc; 14 cars (light); 1 truck (light); 2 LMG.
KStN 2251 1.02.1941	Motorized Field Post Detachment Det: 1 car (medium); 1 bus (medium/33 seats); 2 vans (medium).
SS KStN 26.05.1942	Motorized Clothing Repair Company Co Hqs: 1 mcl; 1 car (light); 4 trucks (medium). 2 Lt Plt: 1 truck (medium); 2 vans (medium). 1 Hvy Plt: 3 trucks (medium); 8 vans (medium); 2 trailers (generator). Maint Sect: 1 car (2/40); 1 truck (medium).

NOTES:

- [1] The corps war correspondent companies each consisted of two war correspondent platoons, united under their senior officer. The platoons had formerly been assigned to SS-Divisions.
- [2] Sources are vague as to whether these were two antiaircraft companies, or whether it was a reduced strength medium company augmented by two platoons from the light company organization.

SS-PANZERKORPS-NACHRICHTENABTEILUNG (mot)
SS-Panzer Corps Signal Battalion (mot)

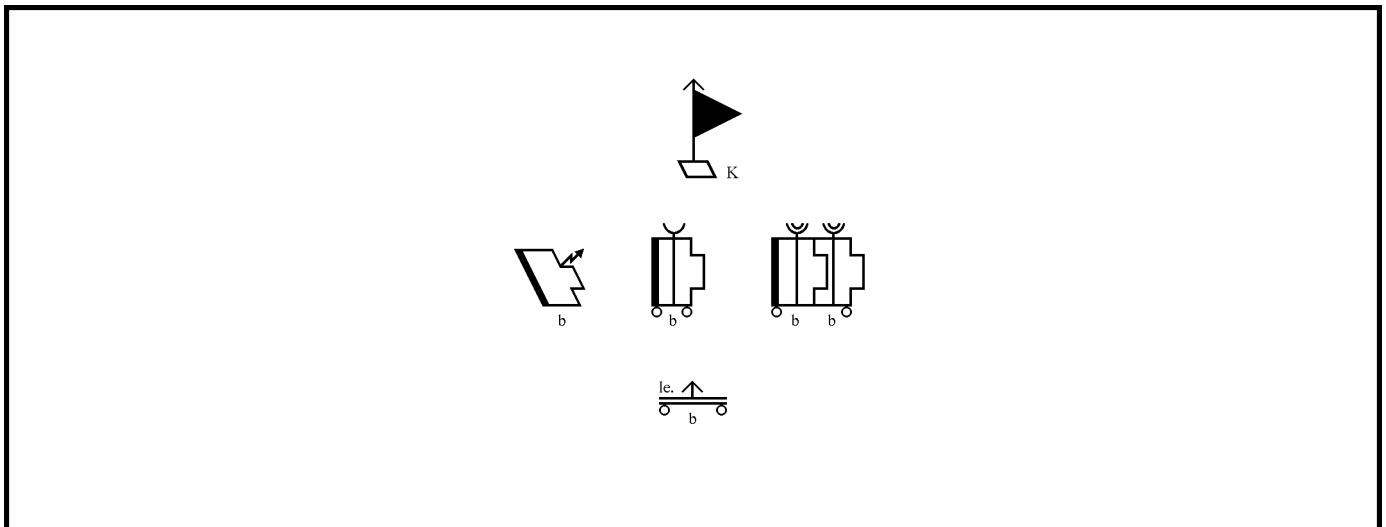

KStN 805
1.03.1943

Headquarters, Corps Signal Battalion (motorized)

Bn Hqs: 2 mcl; 1 car (light); 4 cars (15); 2 trucks (1.5-ton); 2 trucks (medium); 2 LMG.
 Maint Det: 1 mcl w/sc; 1 car (2/40); 1 car (light); 2 trucks (3-ton).

KStN 843 *)
1.03.1942

Corps Field Cable Company "b" (motorized)

Co Hqs: 1 mcl; 1 mcl w/sc; 1 car (15); 1 truck (light); 1 LMG.
 1st Plt, Hqs Sect: 2 mcl; 1 car (15); 1 LMG.
 2nd Plt, Lt Tele Maint Sect: 1 car (15).
 3rd Plt: Med Tele Maint Sect: 1 truck (2-ton).
 3 Field Cable Sect: 1 truck (3-ton).
 Co Maint Sect: 1 mcl w/sc; 1 car (2/40).
 Co Trains: 1 car (15); 6 trucks (medium); 1 LMG.

KStN 833 *)
1.02.1942

Corps Telephone Company "b" (motorized)

Co Hqs: 1 mcl; 1 mcl w/sc; 1 car (15); 1 truck (light); 1 LMG.
 1st Plt: Hqs Sect: 2 mcl; 1 car (15); 1 LMG.
 3 Hvy Tele Ops Sect 80: 2 telephone operations vans.
 1 Med Tele Ops Sect 40: 2 vnas (2-ton).
 2 Lt Tele Amplifier Sect 3: 1 amplifier van.
 2nd Plt & Hqs Sect: 2 mcl; 1 car (15); 1 LMG.
 3rd Plt: 1 Med Tele Maint Sect: 1 truck (2-ton).
 1 Med Cable Sect 12: 1 van (2-ton).
 4 Field Cable Sect 12: 1 van (3-ton).
 Co Maint Sect: 1 mcl w/sc; 1 car (2/40).
 Co Trains: 1 car (15); 7 trucks (medium); 1 LMG.

SS KStN
15.02.1943

Telex Platoon, SS-Corps

Hqs Sect: 1 car (15).
 Telex Calibration Sect: 1 car (12); 1 van (4½-ton); 1 trailer (signal - *Sd.Ah. 25/2*).
 6 Telex Connection Sect: 1 car (15).

KStN 973
1.05.1942

Corps Armored Radio Company "b"

1 mcl; 1 mcl w/sc; 1 car (15); 1 truck (light).
 1st Plt: Hqs Sect: 2 mcl; 1 car (15); 1 LMG.
 Armored Command Radio Sect: 1 armored command vehicle (215/6).
 2 Med Armored Radio Sect *b*: 1 car (15); 1 armored radio car (263).
 2 Med Armored Radio Sect *b/f*: 1 armored radio car (263).
 1 Lt Radio Sect *c*: 1 van (17).
 2nd Plt: Hqs Sect: 2 mcl; 1 car (15); 1 LMG.
 2 Med Armored Radio Sect *b/f*: 1 armored radio car (263).
 2 Med Radio Sect *b*: 1 car (15); 1 van (17).
 1 Lt Radio Sect *c*: 1 van (17).
 3rd Plt: Hqs Sect: 2 mcl; 1 car (15); 1 LMG.
 4 Med Radio Sect *b*: 1 car (15); 1 van (17).
 1 Code Sect: 1 car (15).
 Personnel Section - Radio Receivers
 Co Maint Sect: 1 mcl w/sc; 1 car (2/40).
 Co Trains: 1 car (15); 5 trucks (medium); 1 van (42); 1 trailer (generator - *Sd.Ah. 23*); 1 LMG.

KStN 872 *)
1.03.1942

Corps Signal Column "b" (motorized)

Col: 1 mcl w/sc; 1 car (light); 10 trucks (medium); 2 vans (42); 1 Maultier (3);
 2 trailers (telephone pole - *Sd.Ah. 21*); 1 trailer (generator - *Sd.Ah. 23*); 1 LMG.

NOTES:

The "b" series of signal units were the originally designed for the units assigned to corps.

**SS-SCHWERE PANZER-ABTEILUNG (Tiger)
SS-Heavy Tank Battalion (Tiger)**

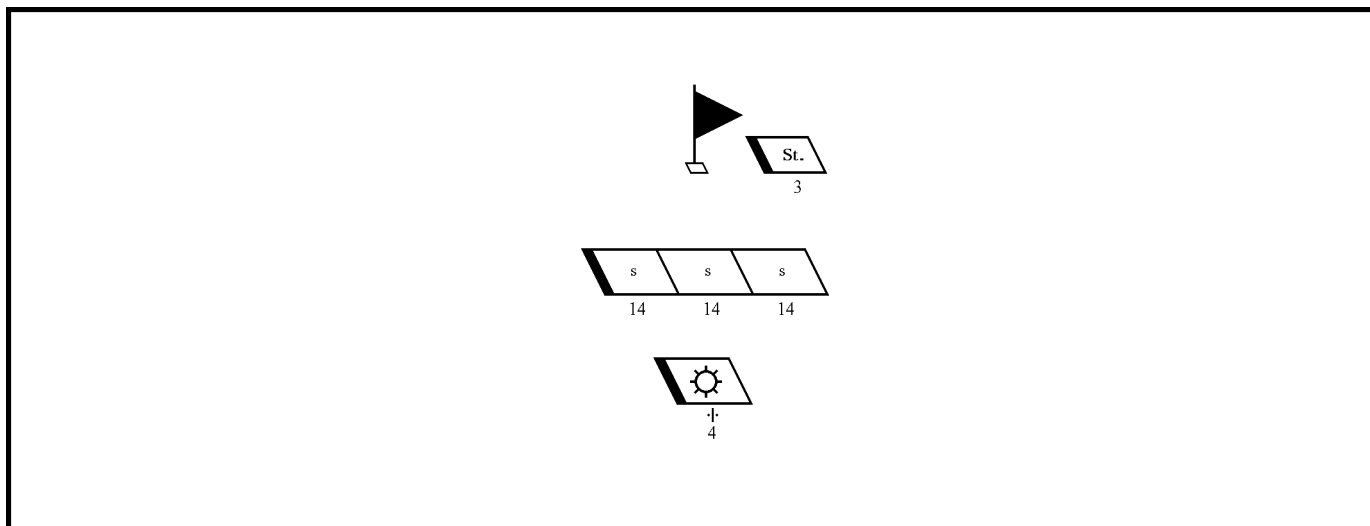

KStN 1107 **Headquarters, Heavy Tank Battalion (Tiger)**
1.04.1943 Bn Hqs: 2 mcl; 3 VW (1); 3 cars (15); 1 truck (2-ton).

KStN 1150e **Headquarters Company, Heavy Tank Battalion (Tiger)**
5.03.1943 Co Hqs: 2 mcl; 1 car (15).
Recon Plt: Hqs Sect: 1 SPW (251/5).
3 Recon Sect: 1 SPW (250/1); 1 SPW (250/5).
Signal Plt: 1 mcl; 1 car (15); 1 Pz-VI (181); 2 Bef-Pz VI (181 as command tanks).
Scout Plt: Hqs Sect: 3 mcl; 1 VW (1).
3 Scout Sect: 2 VW (1); 2 LMG.
Engr Plt: Hqs Sect: 1 mcl; 1 VW (1/20).
3 Engr Sect: 1 KK (2); 1 Maultier (3); 1 SPW (251/7); 1 Engineer Section w/ 1 LMG.
AA Plt: Hqs Sect: 1 mcl; 1 VW (1); 1 LMG.
3 AA Sect: 1 halftrack (7/1 w/ 20 quad Flak 38); 1 Maultier (3).
Co Maint Sect: 1 mcl w/sc; 1 car (2/40).
Co Trains: 2 cars (2); 3 trucks (3-ton); 3 trucks (4½-ton); 2 LMG; equipment for 1 Lt Tele Sect.
Battalion Maintenance Det:
Hqs Sect: 1 car (1).
Main Sect: 1 car (1); 1 truck (3-ton); 1 van (3-ton); 3 trucks (4.5-ton); 1 motor crane (100 – 3-ton capacity);
1 halftrack crane (9/1 – 6-ton capacity); 1 halftrack (10); 1 trailer (generator - *Sd.Ah.* 23); 1 trailer (generator - *A*).
Recovery Sect: 1 car (1); 6 haltracks (9).
Spare Parts Sect: 3 trucks (4½-ton).
Battalion Administration and Service Det:
Det: 1 mcl; 3 cars (1); 1 truck (3-ton); 2 LMG.
Transport Sect: 30 trucks (4½-ton).
Commissary Sect: 1 car (1); 2 truck (4½-ton).
Ambulance Section: 1 mcl w/sc; 1 car (medium); 2 trucks (3-ton); 1 truck (4½-ton); 1 ambulance (31); 1 armored ambulance (251/8).

KStN 1176e **Heavy Tank Company (Tiger)**
5.03.1943 Co Hqs: 3 mcl; 1 mck w/sc; 1 car (15); 2 Pz-VI (181).
3 Plt: 4 Pz-VI (181).
Co Maint Sect: 3 VW (1); 1 car (2/40); 1 truck (3-ton); 1 truck (4.5-ton); 1 halftrack (10).
Co Trains: 1 mcl w/sc; 2 VW (1); 2 trucks (3-ton); 6 trucks (4½-ton); 1 LMG.

KStN 1187b **Motorized Maintenance Company, Heavy Tank Battalion (Tiger)**
25.04.1942 Co Hqs: 2 mcl; 3 VW (1); 1 truck (4.5-ton).
2 Maint Plt: 11 trucks (4.5-ton); 2 vans (4.5-ton); 1 halftrack crane (9/1 – 6-ton); 1 bus (medium/22 seats);
1 trailer (generator Type A for 15k AC); 1 trailer (arc welding); 1 trailer (two axle – 3-ton); 2 LMG.
1 Recovery Plt: 3 VW (1); 1 motor crane (4.5-ton – 3-ton); 1 halftrack crane (9/1 – 6-ton); 10 halftracks (9).
Armorer Det: 1 VW (1); 1 car (15); 2 trucks (4.5-ton).
Signal Maint Sect: 1 truck (2-ton); 1 signal maintenance van (42); 1 battery van (42); 1 trailer (generator for recharging batteries - *Sd.Ah.* 23).
Co Trains: 2 VW (1); 1 car (15); 1 AA car (4 w/ dual MG); 2 trucks (medium); 3 trucks (4.5-ton).

NOTES:

The heavy tank battalions were originally supposed to become corps troops, but in practice remained independent units, assigned where needed.

SS-WERFER-ABTEILUNG (mot)
SS-Rocket Launcher Battalion (mot)

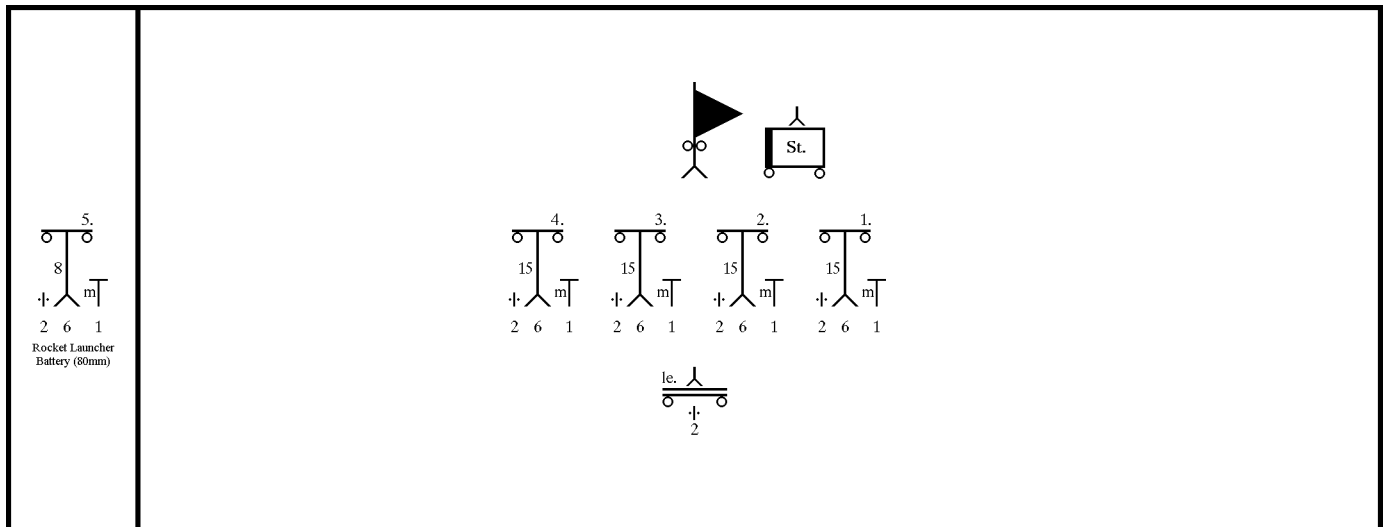
**KStN 607**

1.11.1941

Headquarters, Motorized Heavy Rocket Launcher Battalion

Bn Hqs: 3 mcl; 1 car (1); 3 cars (15).
 Bn Hqs Trains: 2 trucks (medium).

KStN 625 *)

1.02.1943

Headquarters Battery, Motorized Heavy Rocket Launcher Battalion

Bty Hqs: 2 mcl; 1 car (15); 1 armored observation vehicle (253 or 250/5).
 Signal Det: Hqs Sect: 1 car (15).
 2 Hvy Tele Sect *a*: 1 car (2); 1 van (23).
 2 Lt Tele Sect *c*: 1 car (15).
 2 Lt Radio Sect *b*: 1 van (2).
 4 Pack Radio Sect *f*: 1 car (2).
 Calibration Sect: 1 car (15); 1 halftrack (10/1).
 Bty Trains: 2 cars (light); 1 AA car (4 w/ dual MG); 3 trucks (light); 1 ambulance (31).
 Bn Maint Det: 1 mcl w/sc; 1 car (2/40); 1 car (light); 3 trucks (3-ton).
 Bn Trains: 1 car (light); 1 car (medium); 4 trucks (medium); 3 trucks (3-ton).

KStN 617

1.11.1941

Motorized Rocket Launcher Battery (150mm)

Bty Hqs: Hqs Sect: 2 car (1); 1 AA car (4 w/ dual MG).
 Signal Det: Hqs Sect: 1 car (15).
 2 Lt Tele Sect *c*: 1 car (15).
 2 Pack Radio Sect *f*: 1 car (2).
 1 Rocket Plt: Hqs Sect: 1 car (1).
 Launcher Sect: 3 halftracks (11/4); 3 launchers (150mm – towed).
 1 Rocket Plt: Hqs Sect: 1 halftrack (11/4); 1 ATG (50mm – towed).
 Launcher Sect: 3 halftracks (11/4); 3 launchers (150mm – towed).
 2 Ammo Det: 1 mcl w/sc; 3 halftracks (11/4); 3 trailers (ammo).
 Maint Sect: 1 mcl w/sc; 1 car (2/40).
 Bty Trains: 1 car (light); 4 trucks (light); 1 truck (medium).

KStN 667 *)

1.11.1941

Motorized Light Rocket Launcher Column "d"

Col Hqs: 1 mcl; 1 car (light); 2 LMG.
 Ammo Plt: Hqs Sect: 1 car (light).
 3 Ammo Sect: 4 trucks (medium).
 Col Trains: 1 mcl; 3 trucks (light).

SS KStN *)

1.06.1943

Motorized SS-Rocket Launcher Battery (80mm)

Bty Hqs: Hqs Sect: 2 car (1); 1 AA car (4 w/ dual MG).
 Signal Det: Hqs Sect: 1 car (15).
 2 Lt Tele Sect *c*: 1 car (15).
 2 Pack Radio Sect *f*: 1 car (2).
 1 Rocket Plt: Hqs Sect: 1 car (1).
 Launcher Sect: 3 Somua 35(f) with launcher (80mm).
 1 Rocket Plt: Hqs Sect: 1 halftrack (11); 1 ATG (50mm – towed).
 Launcher Sect: 3 Somua 35(f) with launcher (80mm).
 2 Ammo Det: 1 mcl w/sc; 3 halftracks (11); 3 trailers (ammo).
 Maint Sect: 1 mcl w/sc; 1 car (2/40).
 Bty Trains: 1 car (light); 4 trucks (light); 1 truck (medium).

NOTES:

The 102. Rocket Launcher Battalion of the II. SS-Pz-Korps had a fifth battery, equipped with experimental 8cm rockets. The multiple rocket launchers were very similar to the Russian *Katyusha* rail projectors, of which it was a copy. In the Waffen-SS, it was known as the "Himmler-Orgel" (Himmler's pipe organ). The 8cm Vielfachwerfer (multiple projector) were usually mounted on modified French tanks and fired up to 48 rockets in one salvo.

KOMMANDEUR DER SS-PANZERKORPS-NACHSCHUBTRUPPEN
Commander of SS-Panzer Corps Supply Troops

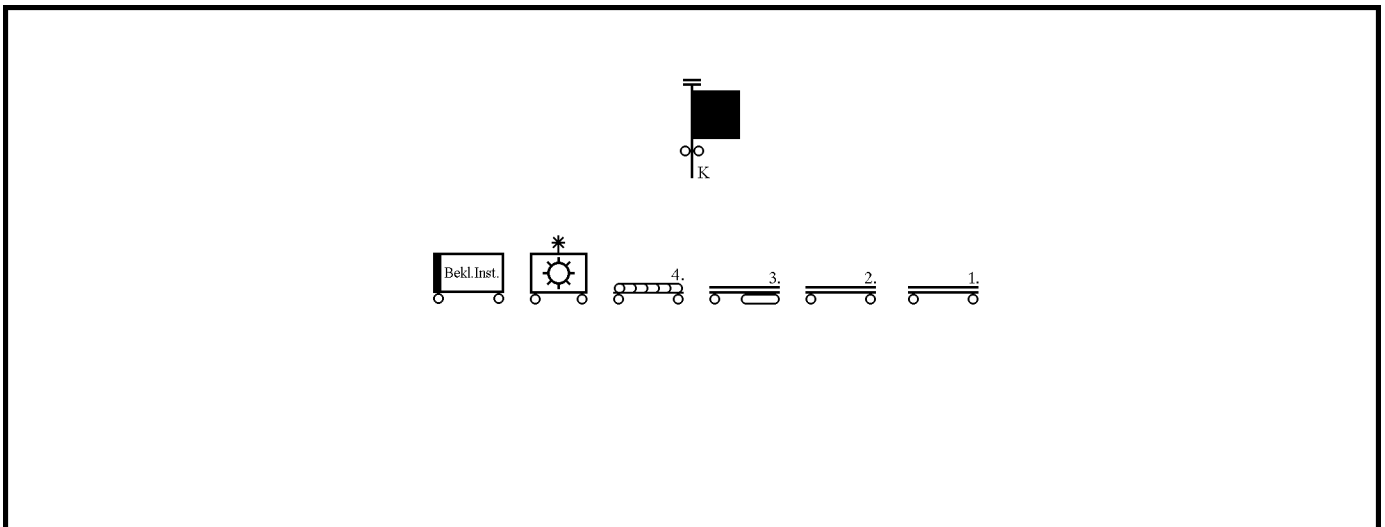

- KStN 1207 *)** **Commander of Corps Supply Troops**
 1.01.1943 Hqs: 2 mcl; 1 mcl w/sc; 3 cars (15); 1 truck (light).
- KStN 1225 *)** **Motorized Light Supply Column (30-ton)**
 1.02.1942 Col Hqs: 1 mcl; 1 mcl w/sc; 1 car (light). [+2 LMG] ⁽¹⁾.
 2 Sect: 5 trucks (medium).
 Col Trains: 1 mcl w/sc; 2 trucks (light).
- KStN 1231 *)** **Motorized Medium Supply Column (60-ton)** ⁽²⁾
 1.03.1942 Col Hqs: 1 mcl; 1 mcl w/sc; 1 car (light). [+2 LMG] ⁽¹⁾.
 4 Sect: 5 halftracked trucks (3-ton).
 Col Trains: 1 mcl w/sc; 2 trucks (light).
- KStN1232 *)** **Motorized P.O.L. Column (50m³)**
 1.03.1942 Col Hqs: 1 mcl; 1 mcl w/sc; 1 car (light). [+2 LMG] ⁽¹⁾.
 4 Sect: 5 trucks (medium).
 Col Trains: 1 mcl w/sc; 2 trucks (light).
- KStN 1051** **Motorized Motor Maintenance Platoon**
 1.02.1941 Plt: 1 mcl; 1 car (medium); 1 truck (light); 1 truck (heavy); 1 motor bus (medium/22 seats); 1 halftrack (7); 1 trailer (spare parts); 1 trailer (generator).

NOTES:

- (1) Organization diagrams often show more LMG in the service units than the original KStN authorized. Therefore they must have authorized at some time by General Army Orders (Allgemeine Heeresmitteilungen.) Where the exact location within the unit is unknown, these additional LMG are placed in square brackets at the end of the headquarters section.
- (2) The organizational diagram indicates that the column is equipped with halftracked vehicles.

SS-PANZERKORPS-SANITÄTSABTEILUNG (mot)
SS-Panzer Corps Motorized Medical Battalion

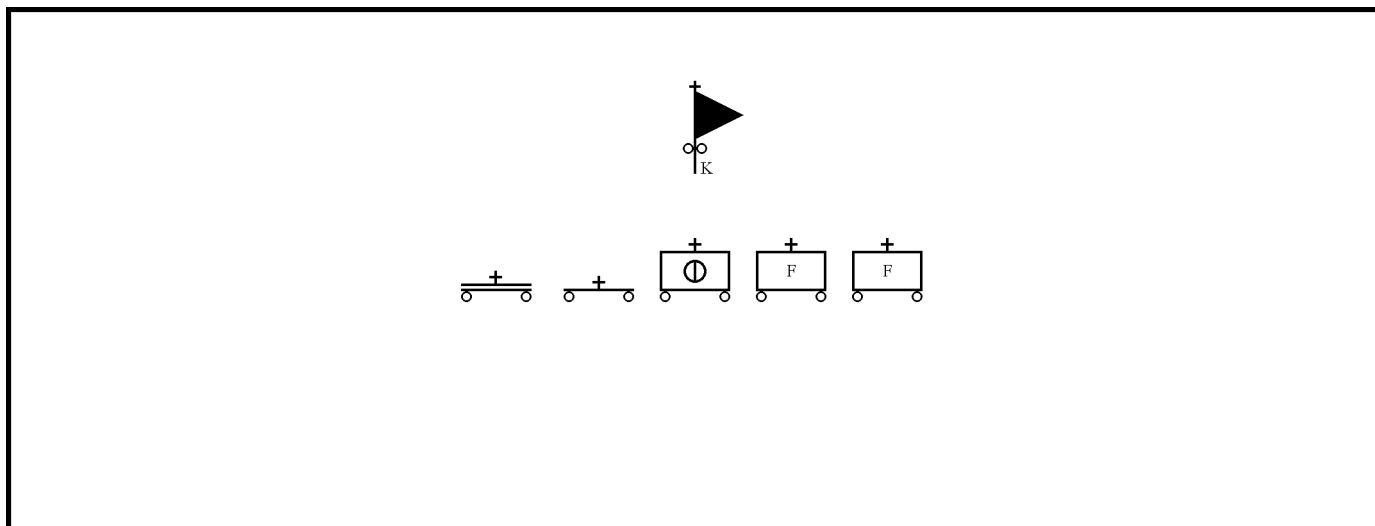

- SS KStN *)**
 1.12.1942 **Headquarters, SS-Corps Medical Battalion**
 Bn Hqs: 1 mcl; 3 cars (medium).
 Lt Tele Sect: 1 car (15).
 Bn Main Det: 1 mcl w/sc; 1 car (2/40); 1 car (medium); 2 trucks (3-ton).
- KStN 1342**
 1.01.1943 **Motorized Field Hospital**
 Hqs Sect: 1 mcl w/sc; 2 cars (medium); 2 trucks (medium); 1 motor bus (light / 15 seats);
 1 trailer (generator - 15/18 kVa); 1 trailer (shower - Sd.Ah. 11).
 2 Plt: 1 car (light); 2 trucks (medium); 1 van (medium); 1 ambulance; 1 motor bus (light / 15 seats).
- SS KStN *)**
 1.12.1941 **Motorized Reinforced Casualty Transport Platoon**
 Plt: 1 car (light); 1 truck (medium); 1 ambulance (31); 4 motor buses (heavy / 34 seats).
- KStN 1365**
 1.11.1941 **Motorized Ambulance Platoon**
 Plt Hqs: 1 car (light); 2 trucks (light). [+1 LMG] ⁽¹⁾
 3 Sect: 5 ambulances (31).
- SS KStN *)**
 1.12.1942 (modified) **Motorized Medical Column**
 Col Hqs: 1 car (light); 2 trucks (light). [+4 LMG] ⁽¹⁾
 3 Sect: 4 trucks (medium).
 Col Trains: 1 car (light); 2 truck (medium).
- SS KStN *)**
 1.07.1943 **Hygiene and Decontamination Det.**
 Det: 1 mcl w/sc; 4 trucks (medium); 1 trailer (generator - 15/18 kVa); 1 trailer (shower - Sd.Ah. 11).

NOTES:

- (1) Organization diagrams often show more LMG in the service units than the original KStN authorized. Therefore they must have authorized at some time by General Army Orders (Allgemeine Heeresmitteilungen.) Where the exact location within the unit is unknown, these additional LMG are placed in square brackets at the end of the headquarters section.

SS-Gebirgskorps



Arko

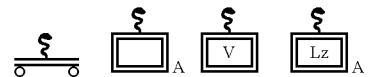
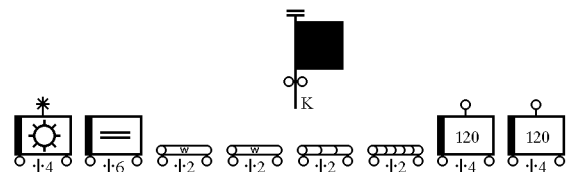
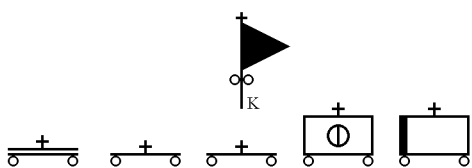
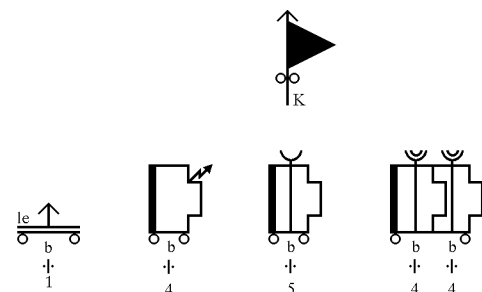
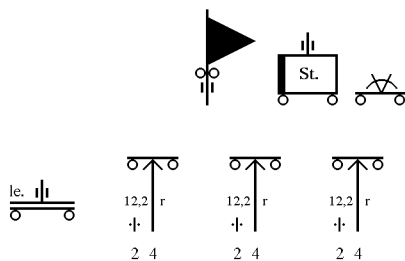
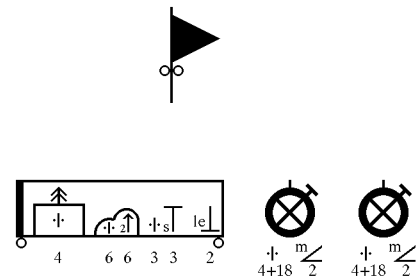
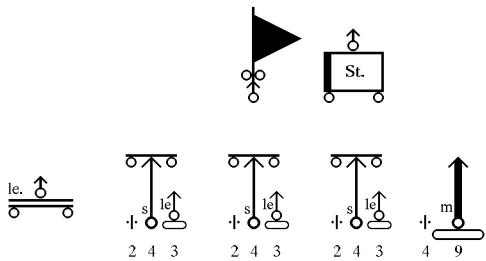
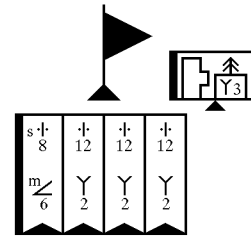
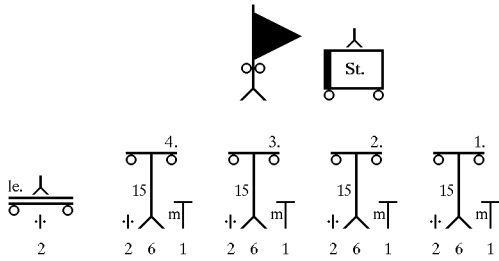
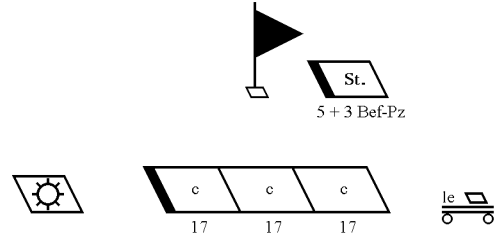
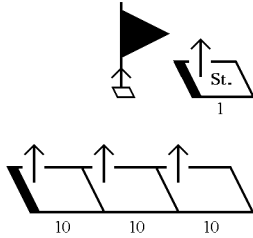
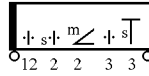

STAB, SS-GEBIRGSKORPS
Headquarters, SS-Mountain Corps

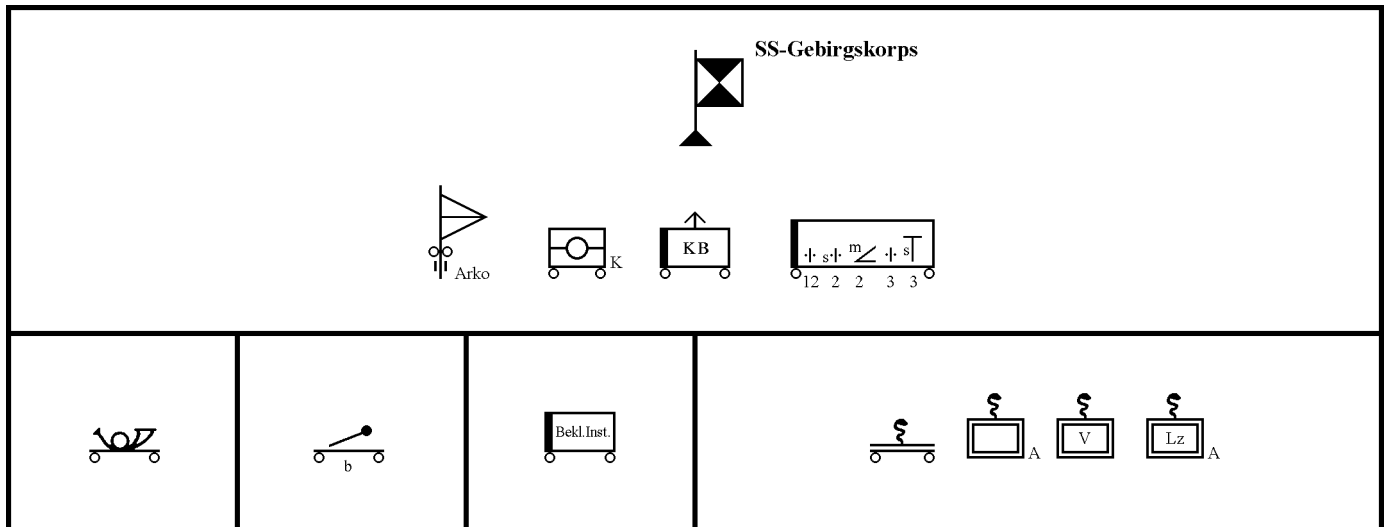

KStN 12
1.03.1942

Headquarters, Mountain Corps

Corps Commander & Chief of Staff
Corps Headquarters

Weapon Staff Officers

Staff Officer for Gas Protection

Corps Administrative Department

Deputy Chief of Staff (*O.Qu.*)

Corps Intendant (*IVa*)

Corps Physician (*IVb*)

Corps Veterinary (*IVc*)

Corps Engineer (*V*)

Political Education Officer (*VI*)

Office of the Adjutant

Adjutant (*IIa*)

Main Records and Files Office

Provost Marshal (*III*)

Headquarters Commandant (*H.Qu.*)

Office of the Commandant: 3 bicycles.

Paymaster General (*IVz*)

Commissary Officer

Corps Motor Pool

Motor Vehicle Detachment: 5 cars (light); 2 cars (medium); 2 cars (heavy); 2 cars (12); 3 trucks (light); 7 trucks (medium);
1 motor bus (converted to office use).

Motorcycle Detachment: 26 mcl; 5 mcl w/sc.

Maintenance Section: 1 mcl w/sc; 1 car (2/40).

Headquarters Guards: 1 infantry squad (# 0-0-3-12) with 2 LMG.

Command	Commander
V. SS-Geb.Korps	SS-Obergruppenführer Arthur Phelps

NOTES:

The Vth SS-Mountain Corps was raised on 01.07.1943 to provide a headquarters for:

– SS-Mountain Division “Prinz Eugen” (later 7. SS-Gebirgs-Division),

– SS-Mountain Division “Hanschar” (later 13. SS-Gebirgs-Division).

All the units received the number 105.

SS-GEBIRGSKORPS
SS-Mountain Corps

KStN 2075 * 1.04.1942	Motorized Corps Map Detachment Det: 2 mcl; 2 cars (1); 1 bus (light/15 seats); 2 vans (medium); 1 trailer (generator).
SS KStN 1.01.1943	Motorized War Correspondent Company [1] 2 Plt: 4 cars (light-cc); 8 cars (medium); 1 film equipment van; 1 loudspeaker van; 2 recording equipment vans (17); 1 truck (light); 4 trucks (medium).
KStN 25 * 1.02.1941	Headquarters, Motorized Artillery Command (Arko) Hqs: 5 mcl; 3 cars (1); 3 cars (15); 1 bus (light/15 seats); 1 van (3-ton).
KStN 1121 1.11.1941	Corps Escort Company Company Headquarters: Hqs Sect: 3 mcl; 2 mcl w/sc; 1 car (15). Lt Tele Sect: 1 car (15). Maint Sect: 1 mcl w/sc; 1 car (2/40). Co Trains: 1 car (15); 1 truck (2-ton); 1 truck (medium); 1 truck (3-ton).
ex KStN 1153 1.11.1941	Motorcycle Plt: Hqs Sect: 3 mcl; 2 cars (15). 2 Sqd: 4 mcl w/sc; 1 Scout Squad w/ 2 LMG.
KStN 1123 1.11.1941	Infantry Gun Plt: Hqs Sect: 1 mcl; 1 mcl w/sc; 1 truck (69). Gun Sect: 3 trucks (69); 2 Lt IG (75mm – towed); 1 trailer (ammo).
ex- KStN 1148a * 1.12.1942	Antitank Plt: Hqs Sect: 1 mcl; 1 mcl w/sc; 1 car (1); 2 Maultier (3). Gun Sect: 3 ATG (76.2mm or 75mm); 3 LMG.
ex- KStN 162 1.02.1941	Machine Gun Plt: Hqs Sect: 1 mcl w/sc; 2 cars (15). 2 MG Sect: 1 truck (medium); 2 HMG. 1 Mortar Sect: 1 car (11); 2 trucks (medium); 2 mortars (81mm).
ex- KStN 138c 1.11.1941	Infantry Plt: Hqs Sect: 1 mcl; 2 LMG (equipment reserve); personnel ride in Infantry Squad trucks. 4 Inf Sqd: 1 truck (medium); 1 Infantry Squad with 1 LMG.
KStN 2033b 1.03.1942	Motorized Corps Military Police Detachment Det: 12 mcl; 4 mcl w/sc; 14 cars (light); 1 truck (light); 2 LMG.
KStN 2251 1.02.1941	Motorized Field Post Detachment Det: 1 car (medium); 1 bus (medium/33 seats); 2 vans (medium).
SS KStN 26.05.1942	Motorized Clothing Repair Company Co Hqs: 1 mcl; 1 car (light); 4 trucks (medium). 2 Lt Plt: 1 truck (medium); 2 vans (medium). 1 Hvy Plt: 3 trucks (medium); 8 vans (medium); 2 trailers (generator). Maint Sect: 1 car (2/40); 1 truck (medium).
KStN 1401 * 1.03.1942	Army Veterinary Hospital (500 horses) Co Hqs: 1 mcl; 1 car (medium); 4 riding horses; 3 bicycles. Collecting Det: 4 mcl w/sc; 12 trucks (heavy); 4 riding horse3; 4 wagons (Vf. 1), each with 4 draught horses. 2 Station Det: 3 riding horses; 4 equipment wagons (Hf. 1) with 4 draught horses; 1 smithy wagon (Hf. 1/13) with 2 draught horses; 1 veterinary equipment wagon (Hf. 1) with 2 draught horses; 1 equipment wagon (Hf. 2) with 2 draught horses; 7 bicycles. Supply Det: 6 trucks(light); 1 field kitchen (Hf.11 or Hf. 13) with 2 draught horses; 1 field kitchen (Hf. 12 or Hf. 14) with 2 draught horses; 2 supply wagons (Hf. 2) each with 4 draught horses; 4 bicycles.
KStN 1441 * 1.03.1942	Army Remount Park (500 horses) [1] Park Hqs: (#6-6-11). 6 Remount Plt: (#1-3-50); 12 light draught horses; 50 draught horses; 34 riding horses; 1 smithy wagon (Hf. 1/13) with 2 draught horses; 2 equipment wagons (Hf. 1) each with 2 light draught horses [*]; 2 equipment wagons (Hf. 2) each with 4 draught horses [*]; 1 training rig with 4 light horses [*]. Park Trains: (0-1-25); 5 trucks (light); 2 field kitchens (Hf.11 or Hf. 13) each with 2 light draught horses.
KStN 1421 *) 1.03.1942	Veterinary Park Park Hqs: (#2-3-1); 1 bicycle. 1st Park Plt: (#1-8-20); 2 mcl w/sc. 2nd Park Plt: (#0-7-6). Motor Pool: (#0-1-9); 1 car (light); 6 trucks (medium); 1 wheeled tractor; 2 trailers (cargo).
KStN 1419 1.03.1942	Motorized Horse Transport Column Col Hqs: 2 mcl; 1 mcl w/sc; 1 car (light). 2 Transport Sect: 1 mcl; 4 trucks (medium). Trains Sect: 3 trucks (light).

NOTES:

[1] The type and number of horses to be maintained in the remount platoons was fixed in the KStN. However, as the SS Mountain Corps, and its intended divisions, were conceived for mountain operations, it is probable that a number of pack animals, and mountain riding horses were included in the above totals, and that the total draught horses and normal riding horses be correspondingly decreased.

[*] These five wagons were pulled by remount horses maintained by the platoon.

Note that the Waffen-SS only differentiated between three types of personnel, (Officer, NCO, Enlisted), as opposed to the four categories in the Wehrmacht. Where Beamte (the missing Waffen-SS personnel category) are present in the original Army KStN, they have been added to the officer total.

SS-PANZER-ABTEILUNG
SS-Tank Battalion

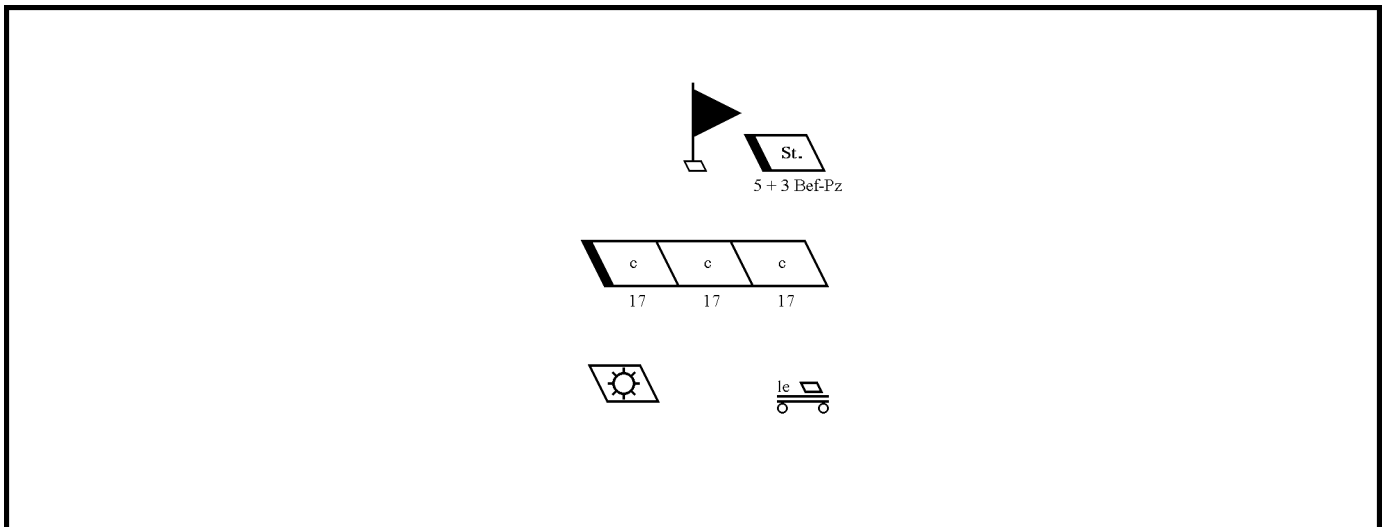
**KStN 1107c Headquarters, Tank Battalion**

1.02.1941
Bn Hqs: 2 mcl; 2 mcl w/sc; 1 car (light); 3 cars (medium-cc).
Bn Trains: 1 mcl; 1 car (light); 2 cars (medium-cc); 1 truck (light).

KStN 1150c Headquarters Company, Tank Battalion

1.02.1941
Co Hqs: 3 mcl; 1 car (medium-cc).
Lt Tank Plt: 1 mcl w/sc; 4 Pz-38 H(f); 1 Pz-35 S(f).
Signal Plt: Hqs Sect: 1 mcl; 3 cars (medium-cc as Kfz. 15).
Armd Radio Det: 2 Bef-Pz-35 S(f); 1 Bef-Pz-38 H(f).
2 Lt Radio Sect c: 1 car (medium-cc as Kfz. 15).
Scout Plt: Hqs Sect: 3 mcl; 1 car (light-cc).
4 Sect: 1 mcl; 2 mcl w/sc; 1 LMG.
Engr Plt: Hqs Sect: 1 mcl; 1 car (medium-cc).
3 Sect: 1 truck (medium-cc); 1 Engineer Section w/ 1 LMG.
1 Sect: 1 truck (medium-cc); 1 Engineer Section.
AA Plt: 1 mcl; 4 AA car (4 with dual MG).
Co Maint Sect: 1 mcl w/sc; 1 car (light-cc as Kfz. 2/40); 1 truck (medium-cc).
Ambulance Sect: 1 mcl w/sc; 1 ambulance (medium van-cc); 1 armored halftrack ambulance.
Bn Trains: 1 mcl w/sc; 1 car (light); 1 car (light-cc); 1 car (medium-cc); 1 truck (light); 2 trucks (medium); 8 trucks (medium-cc);

KStN 1183 (Sd) Motorized Light Transport Column, Tank Battalion

1.02.1941
Col Hqs: 1 mcl; 1 mcl w/sc; 1 car (medium-cc as Kfz. 15).
3 Transport Sect: 8 trucks (medium-cc).
Col Maint Sect: 1 mcl w/sc; 1 car (light-cc as Kfz. 2/40).
Col Trains: 2 trucks (light).

KStN 1185 Motorized Tank Maintenance Platoon

1.06.1942
Plt Hqs: 1 mcl w/sc; 1 car (1).
Workshop Det: 9 trucks (3-ton); 1 van (79); 1 bus (medium/22 seats); 1 trailer (generator - A); 1 trailer (arc welding).
Recovery Det: 1 truck (light); 2 vans (42); 1 trailer (generator - Sd.Ah. 23).
Recovery Det: 1 mcl w/sc; 1 car (1); 1 motor crane (3-ton capacity); 1 halftrack (7); 3 halftracks (9); 1 halftrack crane (9/1 - 6-ton capacity);
1 trailer (10-ton/tank - Sd.Ah. 115); 2 trailer (22-ton/tank - Sd.Ah. 116).
Armorer Sect: 1 mcl w/sc; 1 car (15); 2 trucks (medium).
Plt Trains: 1 mcl w/sc; 1 car (light); 3 trucks (medium).

KStN 1171c Light Tank Company

1.04.1941
Co Hqs: 2 mcl; 1 mcl w/sc; 1 car (medium-cc); 2 Pz-35 S(f).
3 Tank Plt: 4 Pz-38 H(f); 1 Pz-35 S(f).
Co Maint Sect: 3 mcl w/sc; 1 car (light-cc as Kfz. 2/40); 1 truck (medium-cc); 2 halftracks (1-ton).
Co Trains: 1 mcl w/sc; 1 car (light); 1 car (medium-cc); 2 trucks (light); 1 truck (medium); 10 trucks (medium-cc).

NOTES:

This organization had all French motor vehicles and equipment. In the KStN, vehicles are indicated only as being either commercial or cross country. The suffix "-cc" has been used to connote a cross-country vehicle.

The tanks indicated above are:

Pz-35 S(f) modified French Somua *Char 1935-S*.
Bef-Pz-35 S(f) same vehicle converted to a command tank.
Pz-38 H(f) modified French Hotchkiss *Char 1938-H*.
Bef-Pz-38 H(f) same vehicle converted to a command tank.

SS-STURMGESCHÜTZ-ABTEILUNG
SS-Assault Gun Battalion

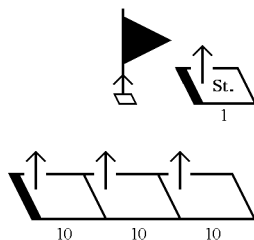

KStN 416
1.12.1942

Headquarters, Assault Gun Battalion

Bn Hqs: 4 mcl; 2 mcl w/sc; 2 cars (15); 1 van (17); 1 ambulance (31); 1 Sturmgeschütz III (142/1).

KStN 588a
1.11.1942

Headquarters Battery, Assault Gun Battalion (Batteries with 10 Guns)

Bty Hqs: 1 mcl; 1 car (15).

Bty Trains: 1 car (light); 1 AA car (4 w/dual MG); 5 trucks (3-ton).

Battalion Maintenance Det:

Ordnance & Signal Maint Sect: 1 car (light); 2 trucks (3-ton).

Motor Maint Sect: 1 mcl; 1 mcl w/sc; 1 car (medium); 1 bus (medium/22 seats); 8 trucks (3-ton); 1 van (79);
1 trailer (generator - A); 1 trailer (arc welding).

Recovery Sect: 2 halftracks (9); 1 motor crane (100 – 3-ton capacity); 2 trailers (22-ton tank - *SdAh. 116*).

KStN 446a
1.11.1942

Assault Gun Battery (10 Guns)

Bty Hqs: 3 mcl; 1 mcl w/sc; 1 car (15); 1 Sturmgeschütz III (142/1).

2 Lt Radio Sect *b*: 1 van (17).

3 AG Plt: Hqs Sect: 2 mcl w/sc.

Ammo Sect: 2 trucks (3-ton); 1 trailer (ammo - *SdAh. 31/1*).

Gun Sect: 3 Sturmgeschütz III (142/1) or 3 Sturmhaubitze III (142/2).

Maint Sect: 2 mcl w/sc; 3 trucks (3-ton).

Bty Trains: 1 mcl; 1 car (1); 1 AA car (4 w/ dual MG); 14 trucks (3-ton).

SS-WERFER-ABTEILUNG (mot)
SS Rocket Launcher Battalion (mot)

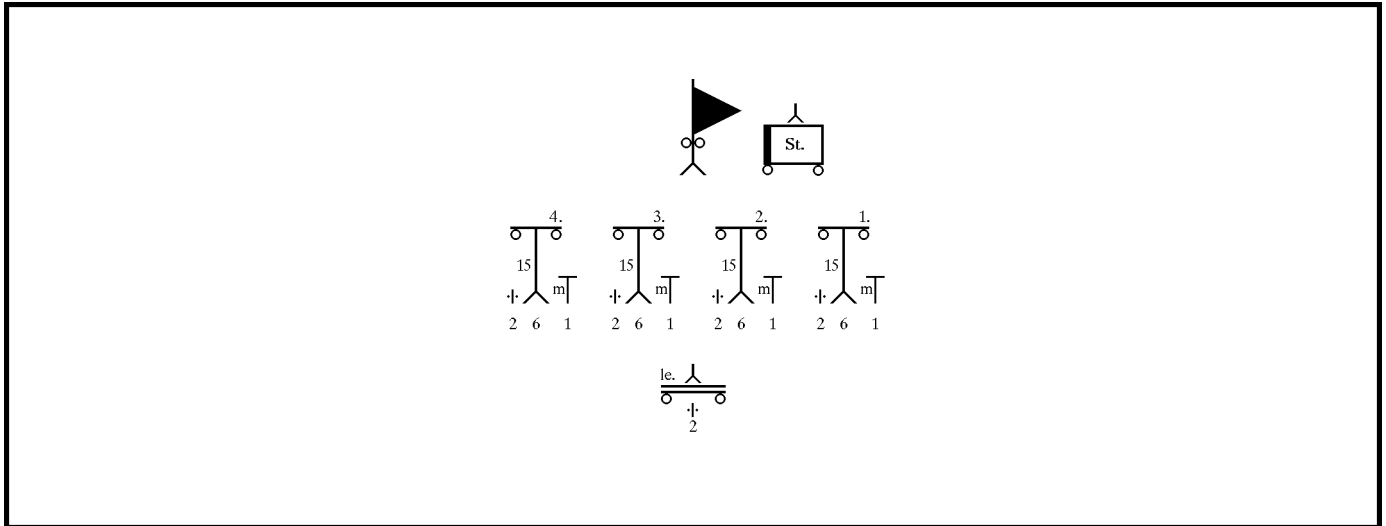
**KStN 607**

1.11.1941

Headquarters, Motorized Heavy Rocket Launcher Battalion

Bn Hqs: 3 mcl; 1 car (1); 3 cars (15).
 Bn Hqs Trains: 2 trucks (medium).

KStN 625 *)

1.02.1943

Headquarters Battery, Motorized Heavy Rocket Launcher Battalion

Bty Hqs: 2 mcl; 1 car (15); 1 armored observation vehicle (253 or 250/5).
 Signal Det: Hqs Sect: 1 car (15).
 2 Hvy Tele Sect *a*: 1 car (2); 1 van (23).
 2 Lt Tele Sect *c*: 1 car (15).
 2 Lt Radio Sect *b*: 1 van (2).
 4 Pack Radio Sect *f*: 1 car (2).
 Calibration Sect: 1 car (15); 1 halftrack (10/1).
 Bty Trains: 2 cars (light); 1 AA car (4 w/ dual MG); 3 trucks (light); 1 ambulance (31).
 Bn Maint Det: 1 mcl w/sc; 1 car (2/40); 1 car (light); 3 trucks (3-ton).
 Bn Trains: 1 car (light); 1 car (medium); 4 trucks (medium); 3 trucks (3-ton).

KStN 617

1.11.1941

Motorized Rocket Launcher Battery (150mm)

Bty Hqs: Hqs Sect: 2 car (1); 1 AA car (4 w/ dual MG).
 Signal Det: Hqs Sect: 1 car (15).
 2 Lt Tele Sect *c*: 1 car (15).
 2 Pack Radio Sect *f*: 1 car (2).
 1 Rocket Plt: Hqs Sect: 1 car (1).
 Launcher Sect: 3 halftracks (11/4); 3 launchers (150mm – towed).
 1 Rocket Plt: Hqs Sect: 1 halftrack (11/4); 1 ATG (50mm – towed).
 Launcher Sect: 3 halftracks (11/4); 3 launchers (150mm – towed).
 2 Ammo Det: 1 mcl w/sc; 3 halftracks (11/4); 3 trailers (ammo).
 Maint Sect: 1 mcl w/sc; 1 car (2/40).
 Bty Trains: 1 car (light); 4 trucks (light); 1 truck (medium).

KStN 667 *)

1.11.1941

Motorized Light Rocket Launcher Column "d"

Col Hqs: 1 mcl; 1 car (light); 2 LMG.
 Ammo Plt: Hqs Sect: 1 car (light).
 3 Ammo Sect: 4 trucks (medium).
 Col Trains: 1 mcl; 3 trucks (light).

SS-ARTILLERIE-ABTEILUNG (mot)
SS Motorized Artillery Battalion

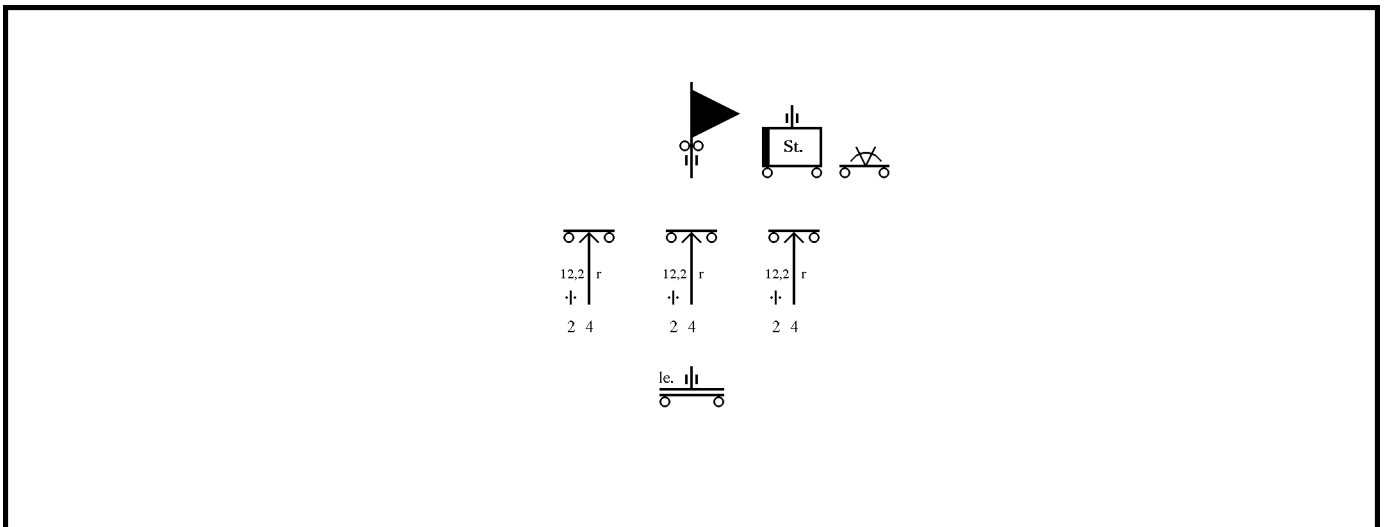

KStN 406
1.11.1941

Headquarters, Motorized Artillery Battalion

Bn Hqs: 3 mcl; 1 mcl w/sc; 1 car (1); 3 cars (15); 1 truck (medium).

KStN 585
1.11.1941

Headquarters Battery, Motorized Artillery Battalion / Panzer Division

Bty Hqs: 2 mcl; 1 car (15); 1 armored observation vehicle (253).

Signal Plt: Hqs Sect: 1 mcl w/sc; 1 van (17/1).

1 Hvy Tele Sect *a*: 1 car (2); 1 van (23).

2 Lt Tele Sect *c*: 1 car (15).

4 Pack Radio Sect *b*: 1 car (2).

1 Lt Radio Sect *c*: 1 van (17/1).

Calibration Sect: 1 mcl; 1 car (3); 1 truck (2-ton).

Maint Sect: 1 mcl w/sc; 1 car (2/40).

Bn Main Det: 1 car (light); 3 trucks (medium).

Bn Trains: 4 mcl; 3 cars (light); 1 car (4 w/ dual MG); 4 trucks (light); 18 trucks (medium); 1 ambulance (31).

KStN 525
1.11.1941

Motorized Calibration Platoon

Plt: 1 mcl; 1 calibration car (3); 1 flash ranging van (63); 1 flash evaluation van (62).

KStN 508 *)
1.11.1941

Motorized Light Artillery Column (15-tons)

Col Hqs: 1 mcl; 1 car (light).

Ammo Plt: 10 trucks (light).

Col Trains: 1 mcl; 1 truck (light).

KStN 454
1.11.1941

Motorized Gun Battery

Bty Hqs: 3 mcl; 2 cars (15).

Signal Det: Hqs Sect: 1 car (15).

Med Tele Sect *b*: 1 signal car (15); 1 observation van (76).

Lt Tele Sect *c*: 1 signal car (15).

Pack Radio Sect *f*: 1 radio car (2).

Lt Radio Sect *c*: 1 radio van (17/1).

Gun Plt: Hqs Sect: 1 mcl; 1 car (1); 1 AA car (4/ dual MG); 1 car (15).

Gun Sect: 5 halftracks (7); 4 guns (Russian 122mm).

Ammo Det: 1 car (light); 4 trucks (3-ton).

Maint Sect: 1 mcl w/sc; 1 car (2/40).

Bty Trains: 4 trucks (medium).

SS-FLAK-ABTEILUNG (mot)
SS Antiaircraft Battalion (mot)

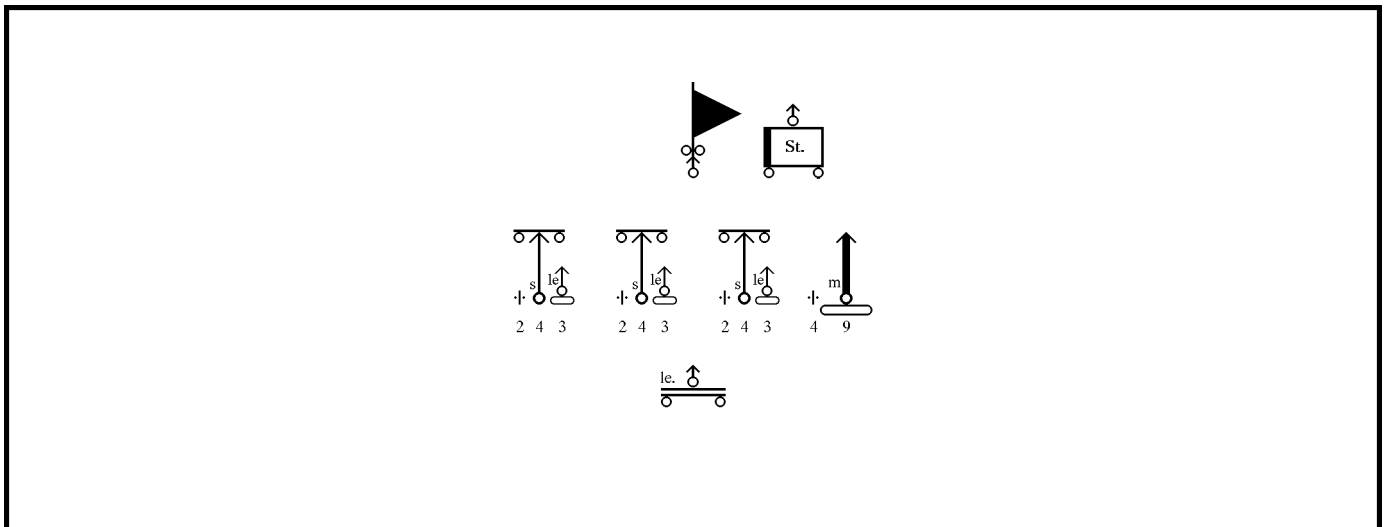

KStN 1705
1.11.1941

Headquarters, Motorized Army Antiaircraft Battalion
Bn Hqs: 3 mcl; 1 car (light); 2 cars (15).

KStN 1709
1.04.1943

Headquarters Battery, Motorized Army Antiaircraft Battalion
Bty Hqs: 1 car (15).
Signal Plt: Hqs Sect: 1 mcl; 1 mcl w/sc; 1 car (15); 1 LMG.
1 Hvy Tele Sect *a*: 1 car (2); 1 van (23).
3 Lt Tele Sect *c*: 1 car (15).
1 Pack Radio Sect *b*: 1 car (2).
1 Lt Radio Sect *a*: 1 van (17).
1 Med Radio Sect *b*: 1 car (15); 1 van (17).
1 Weather Sect: 1 mcl; 1 van (61).
1 Evaluation Sect: 1 truck (medium).
Bty Maint Sect: 1 mcl w/sc; 1 car (2/40).
Bn Maint Det: 1 car (light); 1 truck (medium); 3 trucks (3-ton).
Bn Trains: 1 car (light); 1 car (1); 3 trucks (light); 3 trucks (medium); 1 ambulance (31).

KStN 511
1.03.1943

Motorized Light Artillery Column (20 ton)
Col: 2 mcl; 1 mcl w/sc; 2 trucks (light); 6 trucks (medium).

KStN 1711
1.03.1942

Motorized Heavy 88mm Army Antiaircraft Battery
Bty Hqs: 3 mcl; 2 cars (15).
Calibration Det: Hqs Sect: 1 car (15).
1 Calibration Sect I: 1 van (74); 1 trailer (gun director - *Sd.Ah. 104 or Sd.Ah. 52*).
1 Calibration Sect II: 1 van (74); 1 trailer (auxiliary gun director - *Sd.Ah. 53*).
Signal Det: 1 Hvy Tele Sect *a*: 1 car (2); 1 van (23).
1 Lt Radio Sect *b*: 1 van (17).
Lt AA Plt: 1 mcl w/sc; 3 trucks (81); 3 AA guns (20mm – towed - *Sd.Ah. 51*).
Hvy AA Plt: Hqs Sect: 1 mcl; 1 car (15); 1 halftrack (7); 1 trailer (w/o gun - *Sd.Ah.201/202*).
Gun Sect: 4 halftracks (7); 4 AA guns (88mm – towed - *Sd.Ah.201/202*).
Ammo Det: 4 trucks (3-ton).
Maint Sect: 1 mcl w/sc; 1 car (2/40).
Bty Trains: 1 car (light); 2 trucks (light); 1 truck (medium); 1 truck (3-ton); 1 trailer (ammo).

KStN 198
1.02.1941

Self-Propelled Medium Anti-Aircraft Company
Co Hqs: 2 mcl; 1 car (medium); 1 car (12).
Signal Det: Hqs Sect: 1 car (2).
1 Lt Tele Sect *c*: 1 car (15).
5 Pack Radio Sect *b*: 1 car (2).
3 Med AA Plt: Hqs Sect: 3 mcl; 1 car (15).
Gun Sect: 3 halftracks (6/2 with 37mm Flak); 1 truck (3-ton); 1 LMG.
Ammo Det: 3 trucks (3-ton).
Co Maint Sect: 1 mcl w/sc; 1 car (2/40); 1 truck (medium).
Co Trains: 3 mcl; 1 mcl w/sc; 1 car (15); 2 trucks (light); 2 trucks (1½-ton); 3 trucks (3-ton).

SS-KRADSCHÜTZENBATAILLON
SS Motorcycle Battalion

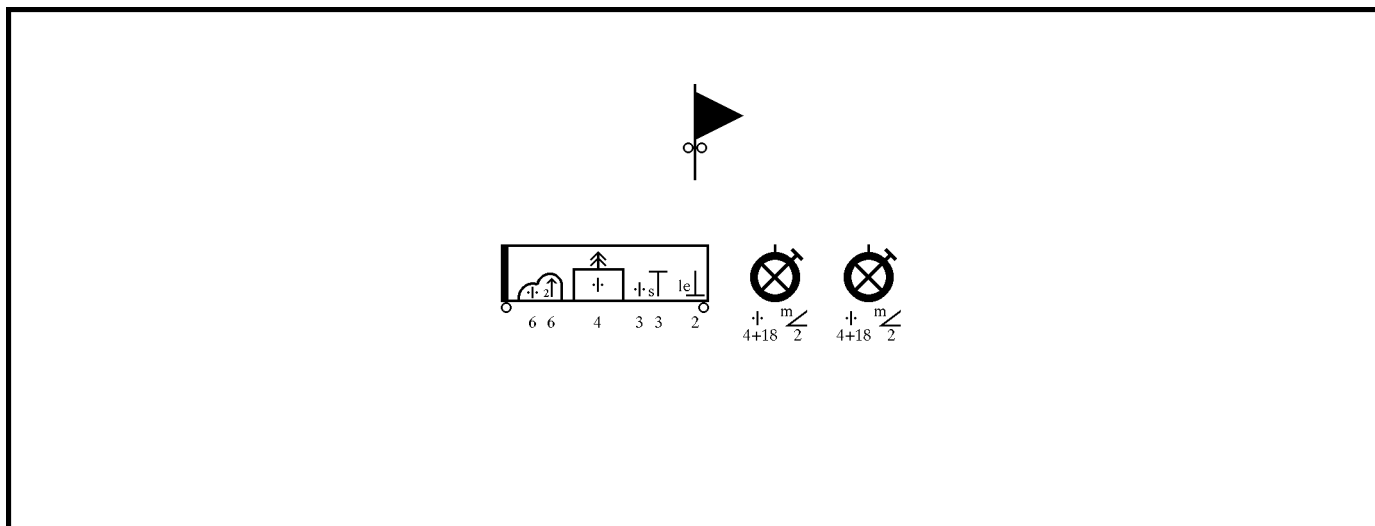
**KStN 1109**

1.11.1941

Headquarters, Motorcycle Reconnaissance Battalion

Bn Hqs: 8 mcl; 2 mcl w/sc; 2 cars (15); 1 armored command car (247).
 Signal Plt: Hqs Sect: 1 mcl; 1 mcl w/sc; 1 car (15).
 2 Pack Radio Sect b: 1 car (2).
 1 Lt Armd Radio Sect b: 1 armored radio car (260).
 4 Lt Armd Radio Sect c: 1 armored radio car (261).
 3 Med Armd Radio Sect b: 1 car (15); 1 armored radio car (263).
 Bn Maint Det:: 1 mcl w/sc; 1 car (2/40); 1 car (light); 2 trucks (3-ton).
 Bn Trains: 1 mcl; 2 cars (light); 1 car (15); 2 trucks (light); 2 trucks (medium); 1 bus (medium/33 seats).

KStN 1112

1.11.1941

Motorcycle Reconnaissance Company

Co Hqs: 4 mcl; 2 mcl w/sc; 1 car (15).
 3 Recon Plt: Hqs Sect: 1 mcl; 2 cars (15); 1 ATR.
 3 Sqd: 4 mcl w/sc; 1 Reconnaissance Squad w/ 2 LMG.
 1 Hvy Plt: Hqs Sect: 1 mcl; 1 mcl w/sc; 2 cars (15).
 2 HMG Sect: 8 mcl w/sc; 2 HMG.
 1 Mortar Sect: 3 trucks (70); 2 mortars (81mm).
 Maint Sect: 1 mcl w/sc; 1 car (2/40).
 Co Trains: 2 mcl; 1 mcl w/sc; 1 car (15); 1 truck (light); 5 trucks (2-ton); 1 truck (3-ton).

KStN 1121

1.11.1941

Motorized Heavy Company

Co Hqs: 3 mcl; 2 mcl w/sc; 1 car (15).
 Lt Tele Sect c: 1 car (15).
 Maint Sect: 1 mcl w/sc; 1 car (2/40).
 Co Trains: 1 car (15); 1 truck (2-ton); 1 truck (medium); 1 truck (3-ton).

KStN 1123

1.11.1941

IG Plt: Hqs Sect: 1 mcl; 1 mcl w/sc; 1 truck (69).
 Ammo Sect: 1 truck (69); 1 trailer (ammo).
 Gun Sect: 2 trucks (69); 2 Lt IG (75mm – towed).

KStN 1145

1.04.1943

AT Plt: Hqs Sect: 1 mcl w/sc; 1 car (1).
 Gun Sect: 5 halftracks (11); 3 antitank guns [1]; 3 LMG.

KStN 1124

1.11.1941

Engr Plt: Hqs Sect: 1 mcl; 1 mcl w/sc; 1 car (15); 2 trucks (2-ton).
 4 Engr Sect: 1 truck (2-ton); 1 Engineer Section w/ 1 LMG.

ex-KStN 1162

1.11.1941

Hvy AC Plt: 3 armored cars (231); 3 armored radio cars (232).

NOTES:

[1] The motorized antitank platoon (KStN 1144) allowed three different antitank guns, the 7,5cm Pak 40, the 7,5cm Pak 97/38, or the 7,52cm Pak 36.

SS-KARSTWEHR-BATAILLON
SS-Mountain Corps Alpine Battalion

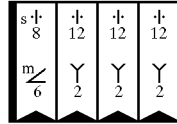
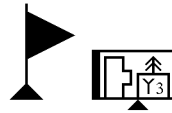
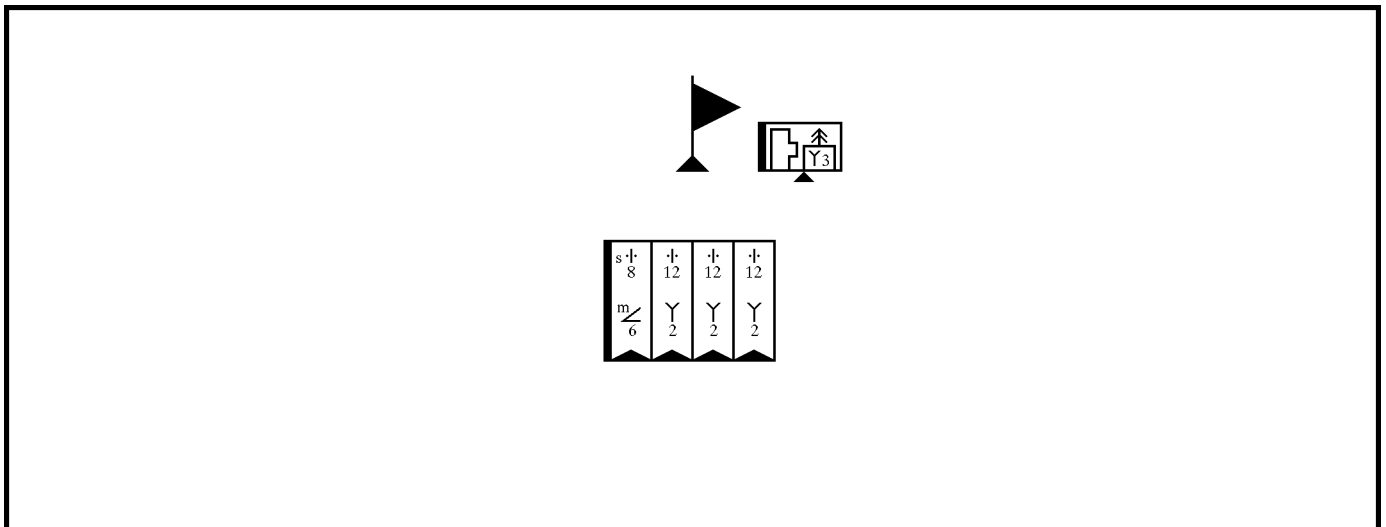

SS KStN
15.02.1943

Headquarters, Mountain Corps Alpine Battalion

Bn Hqs: (# 7 – 2 – 10); 2 mcl; 1 mcl w/sc; 3 cars (light); 1 car (12); 6 riding horses.
 Equipment Section: (# 0 – 0 – 5); 5 pack animals.

SS KStN
15.02.1943

Headquarters Company, Mountain Corps Alpine Battalion

Co Hqs: (# 1 – 1 – 6); 1 mcl w/sc; 1 riding horse; 2 pack animals.
 Signal Plt: Hqs Sect: (# 0 – 1 – 4); 1 pack animal.
 4 Lt Mountain Tele Sect: (# 0 – 1 – 4); 1 pack animal.
 4 Mountain Pack Radio Sect B: (# 0 – 1 – 3); 1 pack animal.
 2 Mountain Heliograph Sect: (# 0 – 1 – 3); 1 pack animal.
 1 Messenger Dog Sect: (# 0 – 0 – 2).
 Engineer Plt: Hqs Sect: (# 1 – 2 – 4); 1 pack animal; 1 halftrack (11); 1 trailer (air compressor and drilling equipment).
 3 Sect: (# 0 – 1 – 18); 5 pack animals; 1 Engrineer Section with 1 LMG.
 Equipment Sect: (# 0 – 1 – 9); 9 pack animals; 3 flamethrowers.
 Co Trains: (# 1 – 16 – 70); 1 truck (1½-ton); 4 trucks (3-ton); 1 ambulance (31); 15 pack animals.

SS KStN
15.02.1943

Alpine Infantry Company

Co Hqs: (# 1 – 2 – 9); 1 riding horse; 2 pack animals; 2 bicycles.
 3 Inf Plt: Hqs Sect: (# 1 – 0 – 6); 1 pack animal.
 3 Inf Sqd: (# 0 – 1 – 10); 1 pack animal; 1 infantry squad with 1 LMG.
 Equipment Sect: (# 0 – 1 – 3); 3 pack animals.
 Engr Sect: (# 0 – 1 – 17); 7 pack animals; 2 flamethrowers.
 Co Trains: (# 0 – 7 – 46); 1 mcl w/sc; 3 trucks (medium); 24 pack animals; 3 LMG.

SS KStN
15.02.1943

Heavy Alpine Company

Hqs Sect: (# 1 – 1 – 8); 2 riding horses; 2 pack animals; 1 mcl; 1 bicycle.
 Signal Det: Hqs Sect: (# 1 – 0 – 0).
 2 Lt Mountain Tele Sect: (# 0 – 1 – 4); 1 pack animal.
 2 Mountain Pack Radio Sect f: (# 0 – 1 – 3); 1 pack animal.
 2 HMG Plt: Hqs Sect: (# 1 – 2 – 9); 1 riding horse; 1 pack animal.
 4 HMG Sect: (# 0 – 1 – 8); 2 pack animals; 1 HMG.
 Mortar Plt: Hqs Sect: (# 1 – 1 – 4); 1 pack animal.
 3 Mortar Sect: (# 0 – 3 – 28); 13 pack animals; 2 mortars (81mm).
 Co Trains: (# 0 – 8 – 40); 1 mcl w/sc; 4 trucks (medium); 24 pack animals.

NOTES:

A *Karstwehr* company was initially formed mid-1942 to operate in the alpine and cisalpine areas of Austrian Tyrol as an anti-partisan unit. The exceedingly rugged terrain in this region is characterized by limestone columns known as karst; hence the name. The company was expanded to battalion size on 15.11.42. There is no direct translation for *Karstwehr*. Literally, it means defence in or of rugged terrain of a mountain above the tree line. That seems to be a somewhat cumbersome title, and lacking a similar Anglo-Saxon mountainous tradition, so I have chosen to use Alpine, (in contrast to Mountain), to describe this unit in English

Note that the Waffen-SS only differentiated between three types of personnel, (Officer, NCO, Enlisted), as opposed to the four categories in the Wehrmacht.

SS-NACHRICHTEN-ABTEILUNG (mot)
SS Motorized Signal Battalion

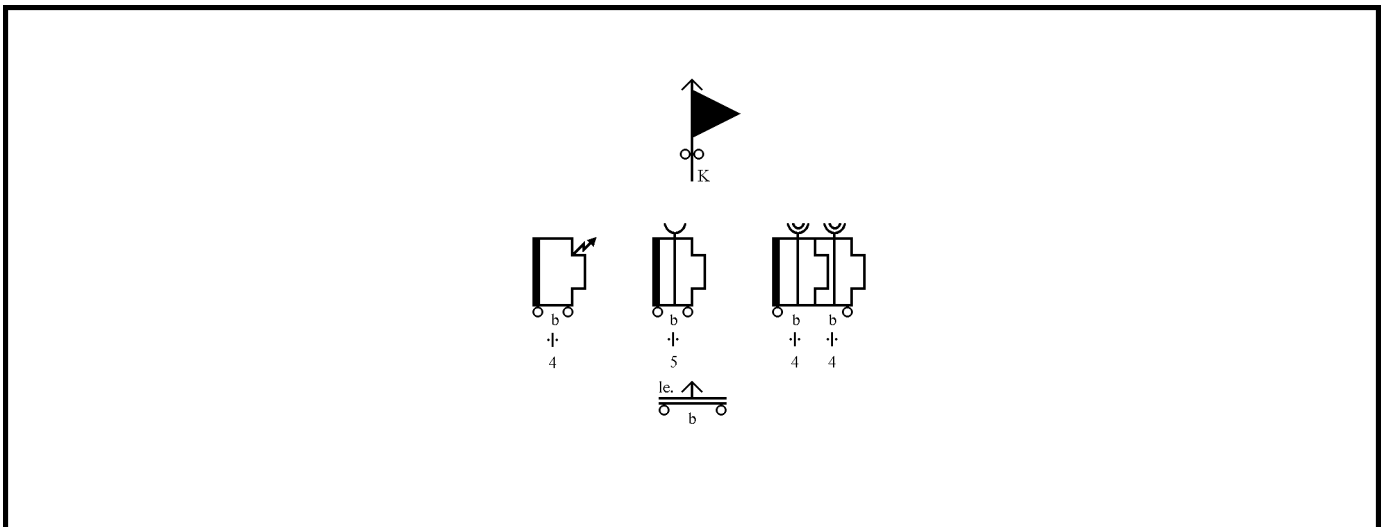

KStN 805
1.03.1943

Headquarters, Corps Signal Battalion (motorized)

Bn Hqs: 2 mcl; 1 car (light); 4 cars (15); 2 trucks (1.5-ton); 2 trucks (medium); 2 LMG.
Maint Det: 1 mcl w/sc; 1 car (2/40); 1 car (light); 2 trucks (3-ton).

KStN 843 *)
1.03.1942

Corps Field Cable Company "b" (motorized)

Co Hqs: 1 mcl; 1 mcl w/sc; 1 car (15); 1 truck (light); 1 LMG.
1st Plt, Hqs Sect: 2 mcl; 1 car (15); 1 LMG.
2nd Plt, Lt Tele Maint Sect: 1 car (15).
3rd Plt: Med Tele Maint Sect: 1 truck (2-ton).
3 Field Cable Sect: 1 truck (3-ton).
Co Maint Sect: 1 mcl w/sc; 1 car (2/40).
Co Trains: 1 car (15); 6 trucks (medium); 1 LMG.

KStN 833 *)
1.02.1942

Corps Telephone Company "b" (motorized)

Co Hqs: 1 mcl; 1 mcl w/sc; 1 car (15); 1 truck (light); 1 LMG.
1st Plt: Hqs Sect: 2 mcl; 1 car (15); 1 LMG.
3 Hvy Tele Ops Sect 80: 2 telephone operations vans.
1 Med Tele Ops Sect 40: 2 vnas (2-ton).
2 Lt Tele Amplifier Sect 3: 1 amplifier van.
2nd Plt & Hqs Sect: 2 mcl; 1 car (15); 1 LMG.
3rd Plt: 1 Med Tele Maint Sect: 1 truck (2-ton).
1 Med Cable Sect 12: 1 van (2-ton).
4 Field Cable Sect 12: 1 van (3-ton).
Co Maint Sect: 1 mcl w/sc; 1 car (2/40).
Co Trains: 1 car (15); 7 trucks (medium); 1 LMG.

SS KStN
15.02.1943

Telex Platoon, SS-Corps

Hqs Sect: 1 car (15).
Telex Calibration Sect: 1 car (12); 1 van (4½-ton); 1 trailer (signal - *Sd.Ah.* 25/2).
6 Telex Connection Sect: 1 car (15).

KStN 860 *)
1.04.1942

Corps Radio Company "b" (motorized)

Co Hqs: 1 mcl; 1 mcl w/sc; 1 car (15); 1 truck (light); 1 LMG.
1st Plt: Hqs Sect: 2 mcl; 1 car (15); 1 LMG.
4 Med Radio Sect 100 Mw: 1 van (2-ton).
1 Coding Sect: 1 truck (3-ton).
2nd Plt: Hqs Sect: 2 mcl; 1 car (15); 1 LMG.
6 Med Radio Sect 80 Mw: 1 van (2-ton).
3rd Plt: Hqs Sect: 2 mcl; 1 car (15); 1 LMG.
2 Med Radio Sect 15 Mw: 1 van (2-ton).
2 Med Air Liaison Radio Sect 20 Mw: 1 van (2-ton).
Co Maint Sect: 1 mcl w/sc; 1 car (2/40).
Co Trains: 1 car (15); 5 trucks (medium); 1 van (42); 1 trailer (generator - *Sd.Ah.* 23); 1 LMG.

KStN 872 *)
1.03.1942

Corps Signal Column "b" (motorized)

Col: 1 mcl w/sc; 1 car (light); 10 trucks (medium); 2 vans (42); 1 Maultier (3);
2 trailers (telephone pole - *Sd.Ah.* 21); 1 trailer (generator - *Sd.Ah.* 23); 1 LMG.

NOTES:

The "b" series of signal units were the originally designed for the the units assigned to corps.

SS-GEBIRGSKORPS-SANITÄTSABTEILUNG (mot)
SS-Mountain Corps Motorized Medical Battalion

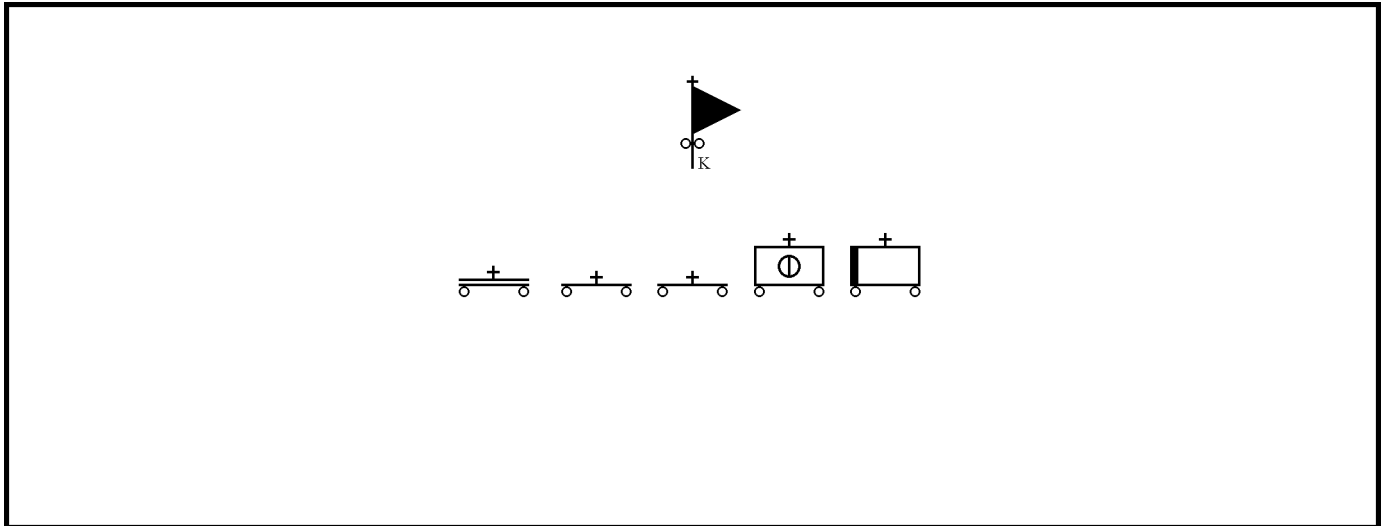

- SS KStN *)**
 1.12.1942 **Headquarters, SS-Corps Medical Battalion**
 Bn Hqs: 1 mcl; 3 cars (medium).
 Lt Tele Sect c: 1 car (15).
 Bn Main Det: 1 mcl w/sc; 1 car (2/40); 1 car (medium); 2 trucks (3-ton).
- SS KStN**
 1.01.1943 **Motorized Medical Company "o"**
 Co Hqs: 2 mcl; 3 cars (15); 3 trucks (medium).
 Lt Tele Sect c: 1 car (15).
 Admin Sect: 1 mcl w/sc; 1 car (medium); 1 truck (medium).
 Maint Sect: 1 mcl w/sc; 1 car (2/40); 1 truck (medium).
 2 Medical Plt: 1 mcl w/sc; 2 cars (medium); 11 trucks (medium); 4 ambulances (31).
- SS KStN *)**
 1.12.1941 **Motorized Reinforced Casualty Transport Platoon**
 Plt: 1 car (light); 1 truck (medium); 1 ambulance (31); 4 motor buses (heavy / 34 seats).
- KStN 1365**
 1.11.1941 **Motorized Ambulance Platoon**
 Plt Hqs: 1 car (light); 2 trucks (light). [+1 LMG] ⁽¹⁾
 3 Sect: 5 ambulances (31).
- SS KStN *)**
 1.12.1942
 (modified) **Motorized Medical Column**
 Col Hqs: 1 car (light); 2 trucks (light). [+4 LMG] ⁽¹⁾
 3 Sect: 4 trucks (medium).
 Col Trains: 1 car (light); 2 truck (medium).
- SS KStN *)**
 1.07.1943 **Hygiene and Decontamination Det.**
 Det: 1 mcl w/sc; 4 trucks (medium); 1 trailer (generator - 15/18 kVa); 1 trailer (shower - *Sd.Ah. 11*).

NOTES:

- (1) Organization diagrams often show more LMG in the service units than the original KStN authorized. Therefore they must have authorized at some time by General Army Orders (Allgemeine Heeresmitteilungen.) Where the exact location within the unit is unknown, these additional LMG are placed in square brackets at the end of the headquarters section.

KOMMANDEUR DER SS-GEBIRGSKORPS-NACHSCHUBTRUPPEN
Commander of SS-Mountain Corps Supply Troops

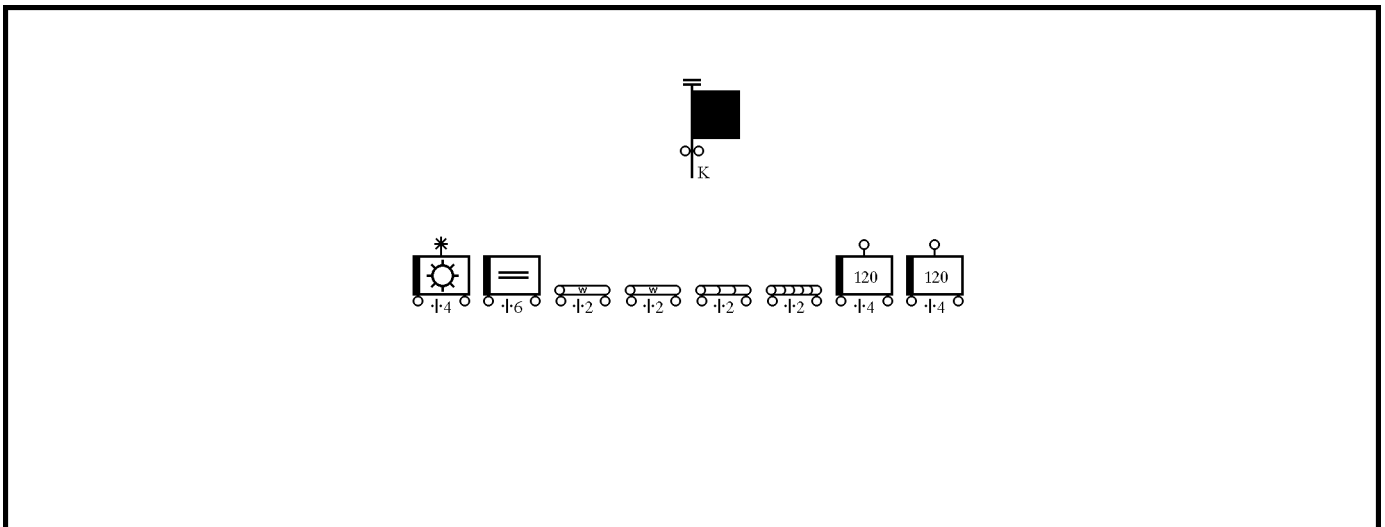

KStN 1207 *) 1.01.1943	Commander of Corps Supply Troops Hqs: 2 mcl; 1 mcl w/sc; 3 cars (15); 1 truck (light).
KStN 1217b *) 1.11.1942	Motorized Transport Company (120 tons) Co Hqs: 1 mcl; 1 mcl w/sc; 2 cars (light). 4 Plt: 10 trucks (medium); 1 LMG. Col Trains: 1 mcl w/sc; 4 trucks (light).
KStN 1232 *) 1.03.1942	Motorized P.O.L. Transport Column (50 m³) Col Hqs: 1 mcl; 1 mcl w/sc; 2 cars (light). [+ 2 LMG] ⁽¹⁾ 4 Sect: 5 trucks (medium). Col Trains: 1 mcl w/sc; 2 trucks (light).
KStN 1226 *) 1.03.1942	Motorized P.O.L. Transport Column (25 m³) Col Hqs: 1 mcl; 1 mcl w/sc; 2 cars (light). [+ 2 LMG] ⁽¹⁾ 2 Sect: 5 trucks (medium). Col Trains: 1 mcl w/sc; 2 trucks (light).
KStN 1227 *) 1.03.1942	Motorized Water Transport Platoon Col Hqs: 1 mcl; 1 mcl w/sc; 2 cars (light). [+ 2 LMG] ⁽¹⁾ 3 Sect: 5 trucks (medium). Col Trains: 1 mcl w/sc; 2 trucks (light).
KStN 1255 *) 1.03.1942	Motorized Supply Company Co Hqs: 2 mcl w/sc; 1 car (light); 1 truck (light). [+ 6 LMG] ⁽¹⁾ 3 Supply Plt: 1 mcl w/sc; 3 trucks (medium). 1 Technical Plt: 1 mcl w/sc; 3 trucks (medium). Co Trains: 1 mcl; 1 truck (light).
KStN 1052 1.11.1941	Motorized Motor Maintenance Company Co Hqs: 1 mcl; 1 car (light). [+4 LMG] ⁽¹⁾ 2 Workshop Plt: 1 mcl w/sc; 1 car (light); 1 truck (light); 1 truck (heavy); 1 bus (medium/31 seats); 1 van (79); 1 halftrack (7); 1 trailer (generator); 1 trailer (tool). 1 Armorer Plt: 2 mcl w/sc; 1 truck (light); 4 trucks (medium). Co Trains: 1 mcl; 1 car (light); 3 trucks (light).

NOTES:

(1) Organization diagrams often show more LMG in the service units than the original KStN authorized. Therefore they must have authorized at some time by General Army Orders (Allgemeine Heeresmitteilungen.) Where the exact location within the unit is unknown, these additional LMG are placed in square brackets at the end of the headquarters section.

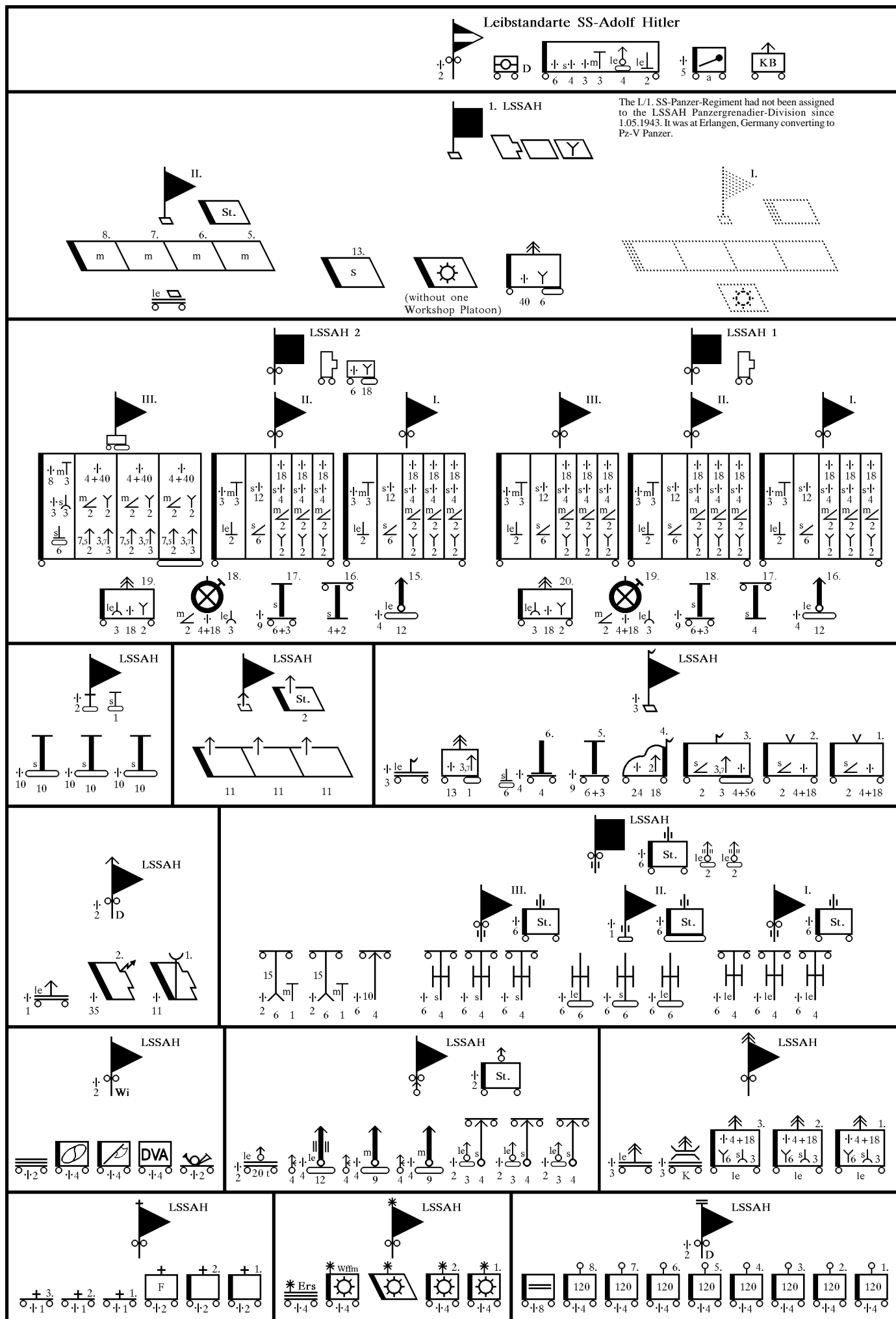

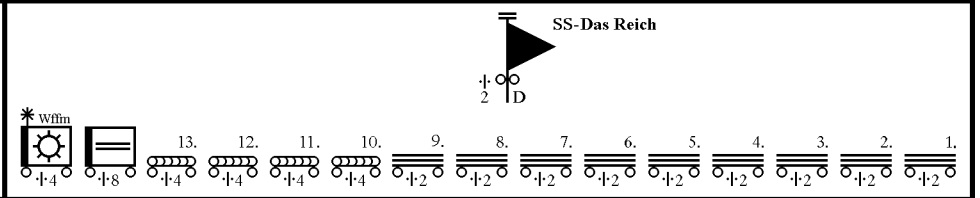
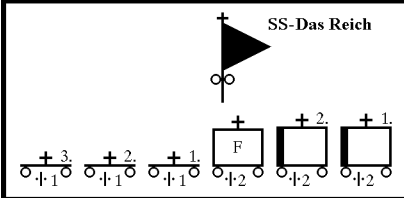
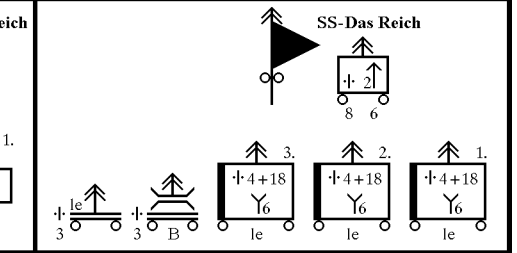
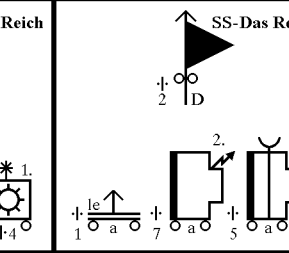
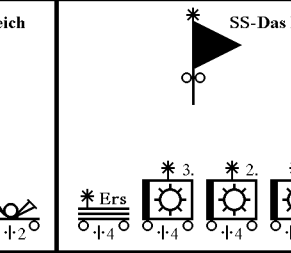
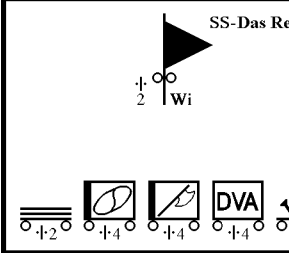
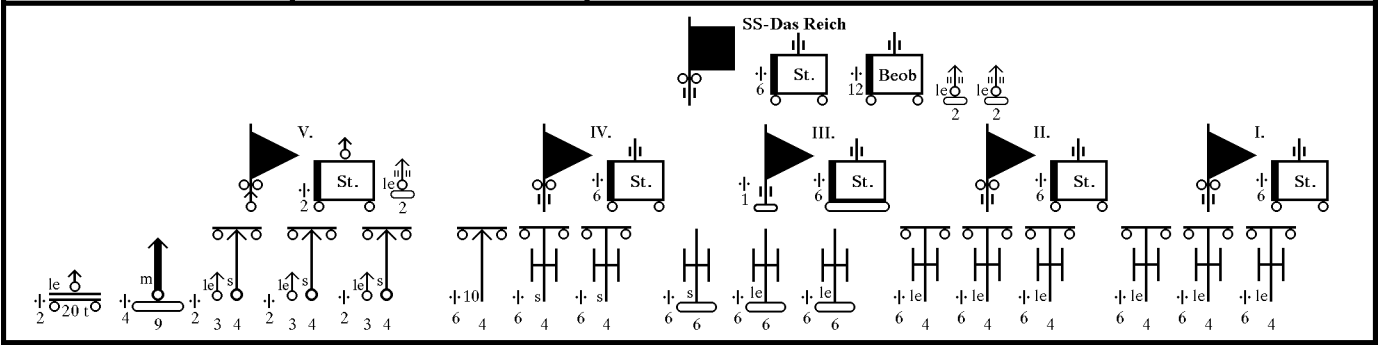
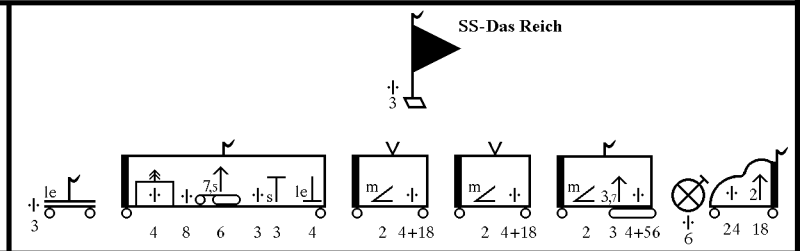
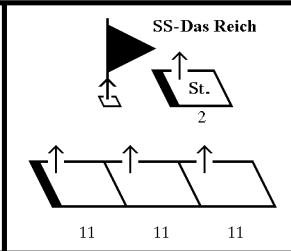
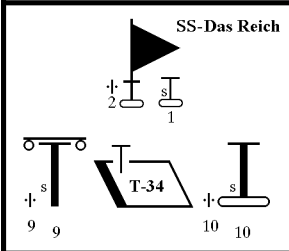
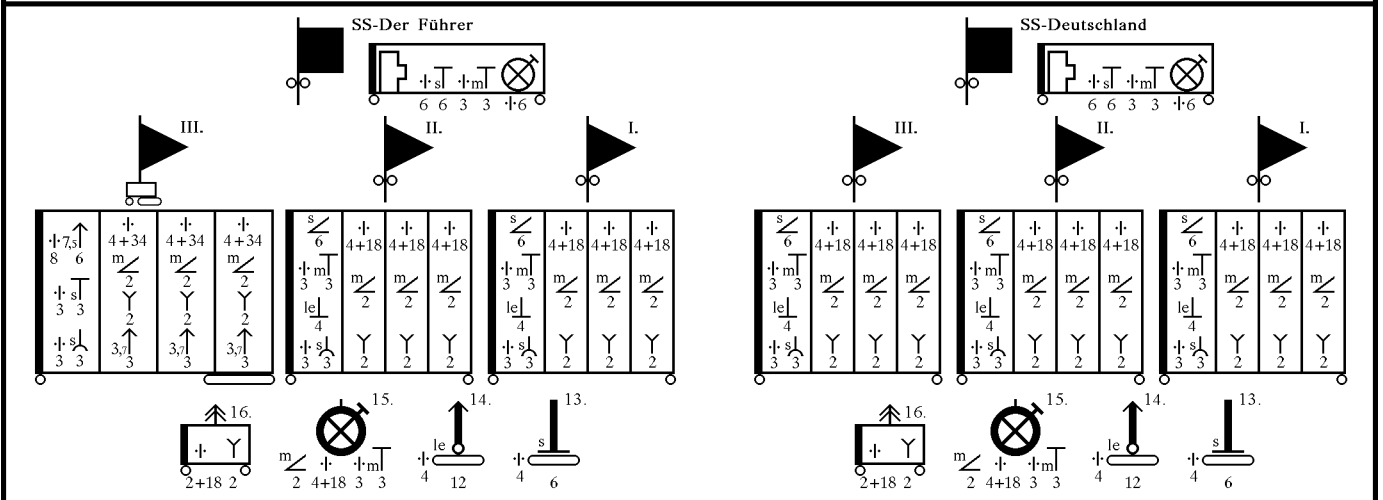
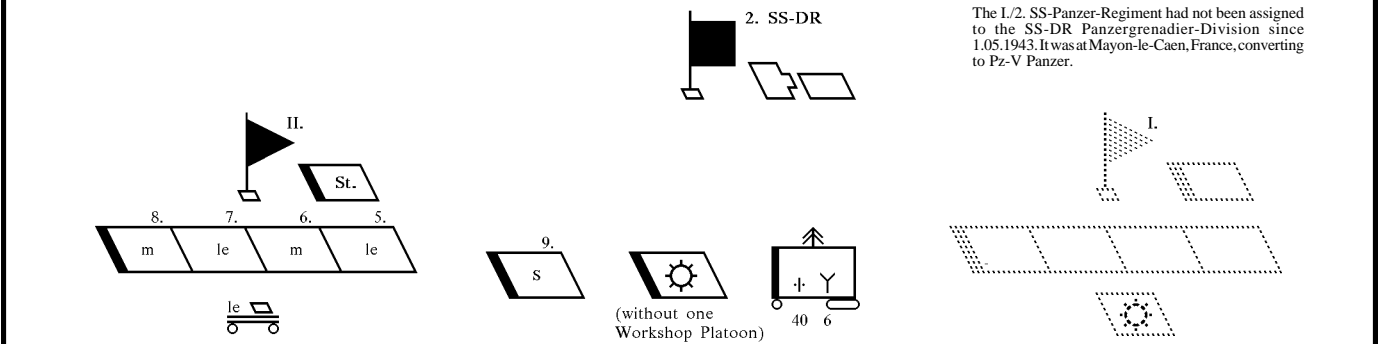
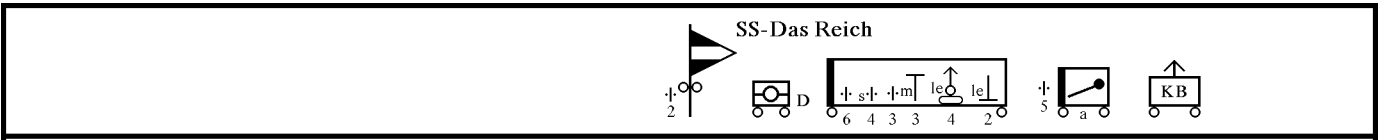

Planned organization of a new SS-Polizei-Panzergrenadier-Division as of 30.06.43, from Polizei units forming in Poland since September 1942. The organization changed by the time the new division saw combat in November 1943. Note that there was also the original, non-motorized SS-Polizei-Division on the East Front at this time, the last elements of which finally joined the new division in April 1944.

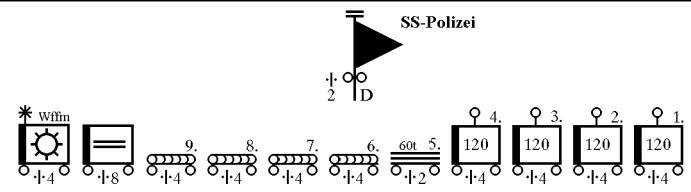
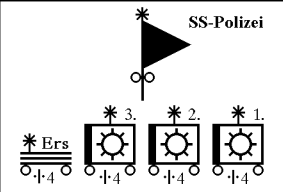
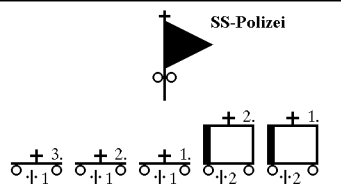
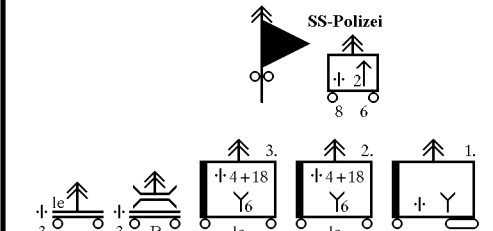
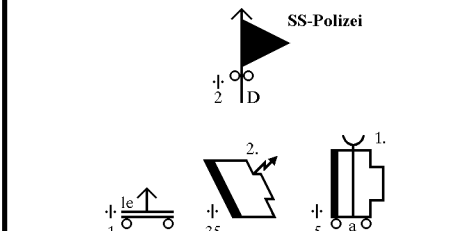
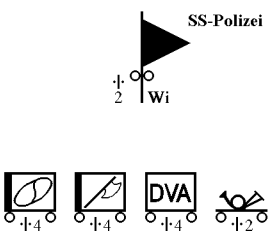
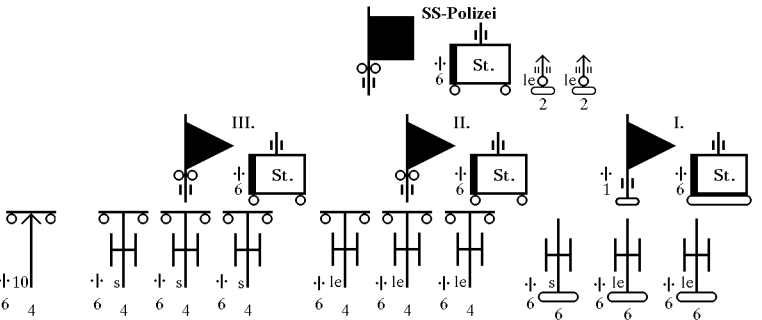
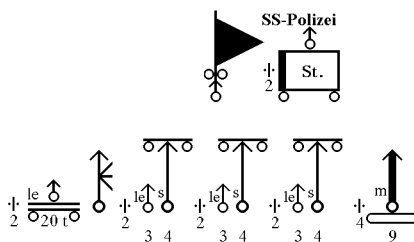
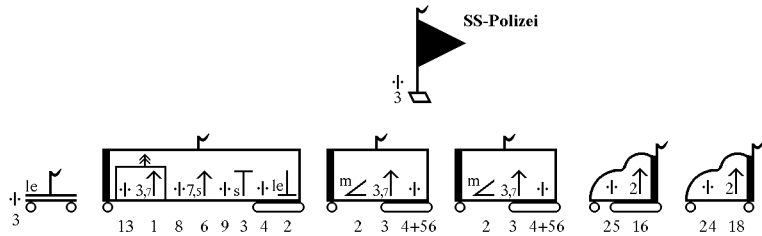
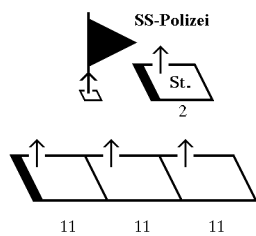
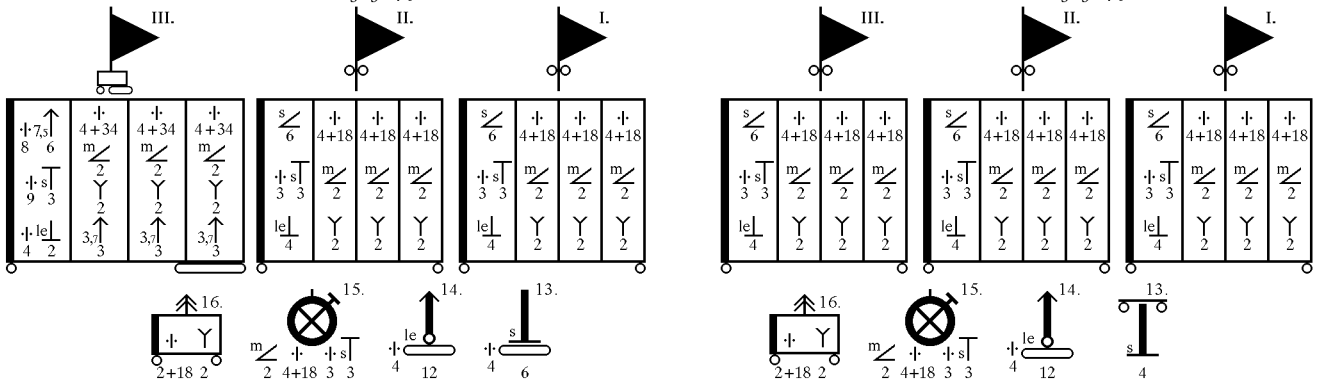
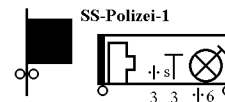
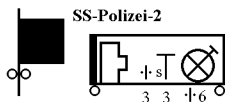
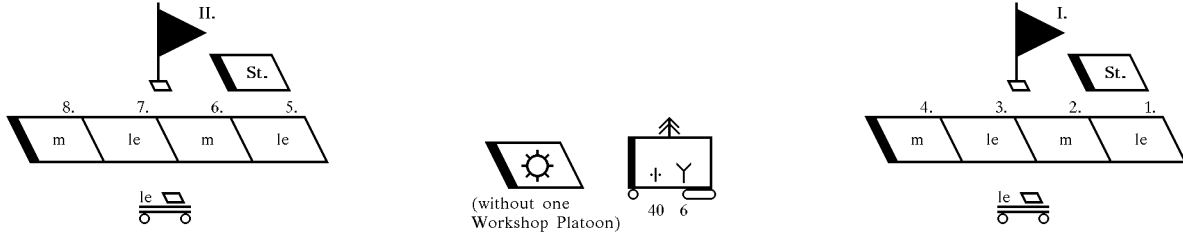
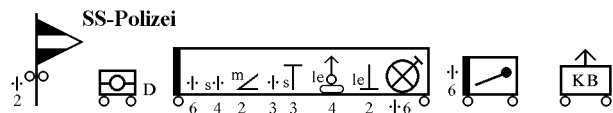

1.07.1943

SS Wiking

The Headquarters, 5. SS-Panzer-Regiment and the II./5. SS-Panzer-Regiment were not with the SS-W Panzergrenadier-Division yet. They were training at Altenaus Training Grounds, Germany, where they had been raised on 28.02.1943.

5. SS-Wiking

L/5. SS-Panzer Regiment tank strength:
 Bn. Hqs: 1 Bef-Pz-III + 1 Pz-III(kz) + 2 Pz-II
 1. Co.: 7 Pz-III(lg) + 4 Pz-III(75) + 2 Pz-IV(lg)
 2. Co.: 7 Pz-III(lg) + 4 Pz-III(75) + 2 Pz-IV(lg)
 3. Co.: 1 Pz-IV(kz) + 12 Pz-IV(lg)
 Stug Bty: 9 StuGesch III

SS-Narwa

SS-Germania

SS-Westland

SS-Wiking

SS-Wiking

SS-Wiking

SS-Wiking

SS-Wiking

SS-Wiking

SS-Wiking

SS-Wiking

SS-Wiking

This is the planned organization of SS-Panzergranadier-Division "Hohenstaufen" as of 30.06.1943. The division was never organized in this form, and was subjected to various changes until it first saw combat in February 1944.

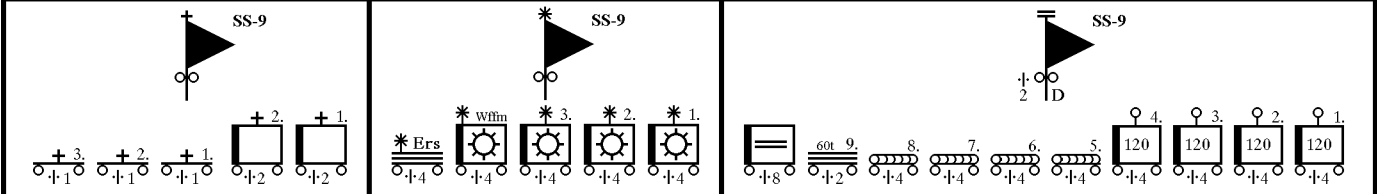
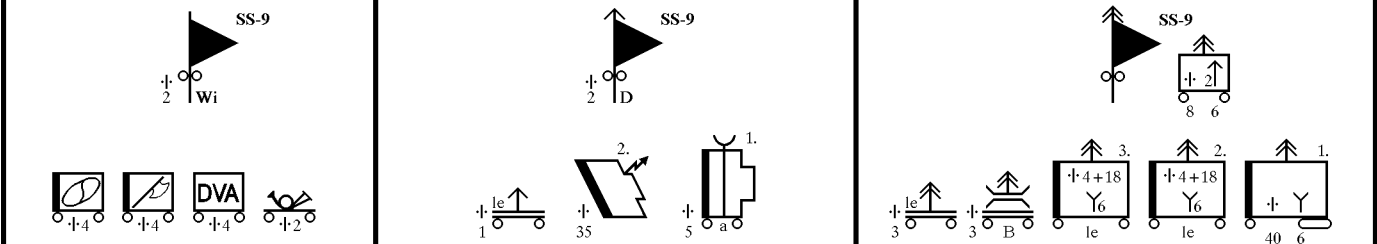
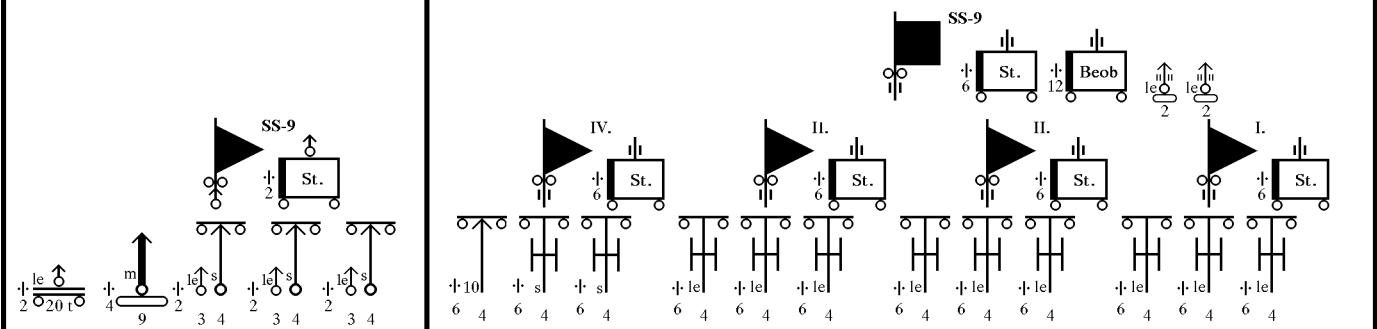
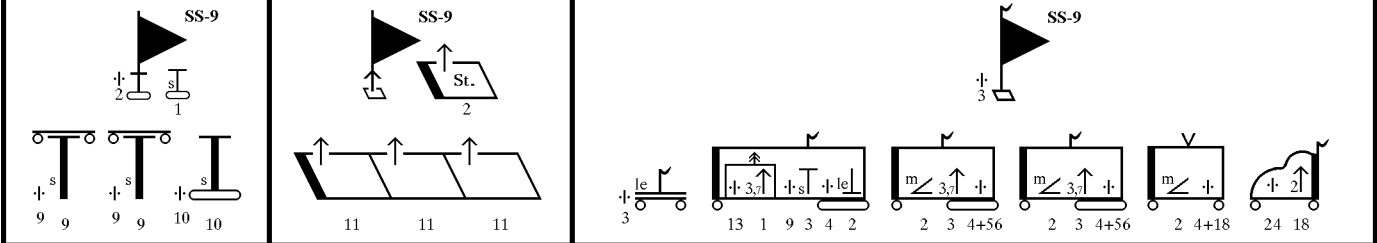
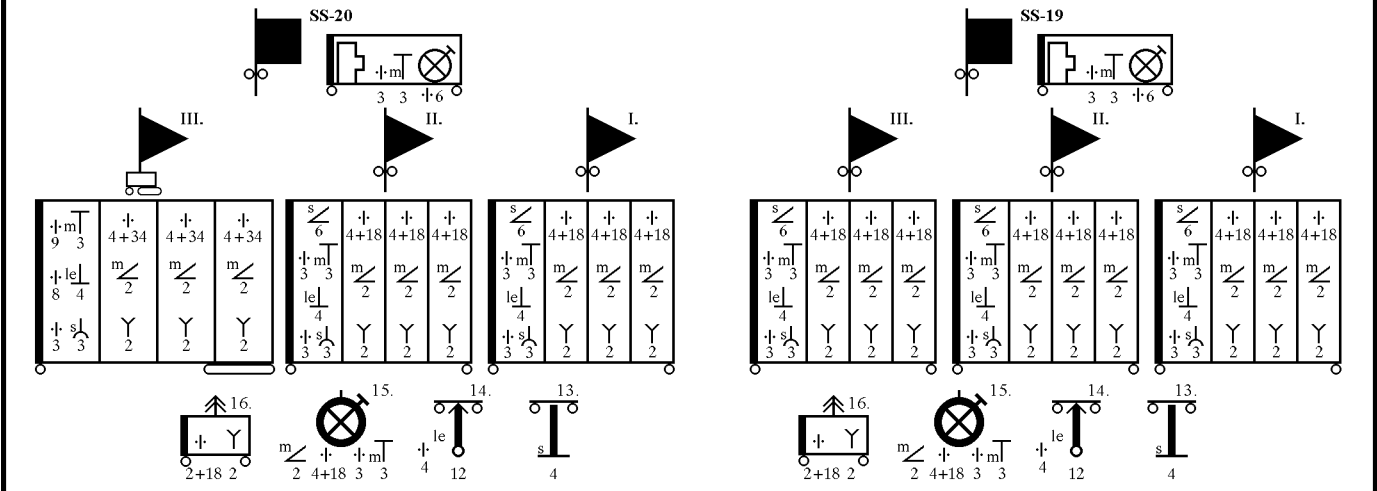
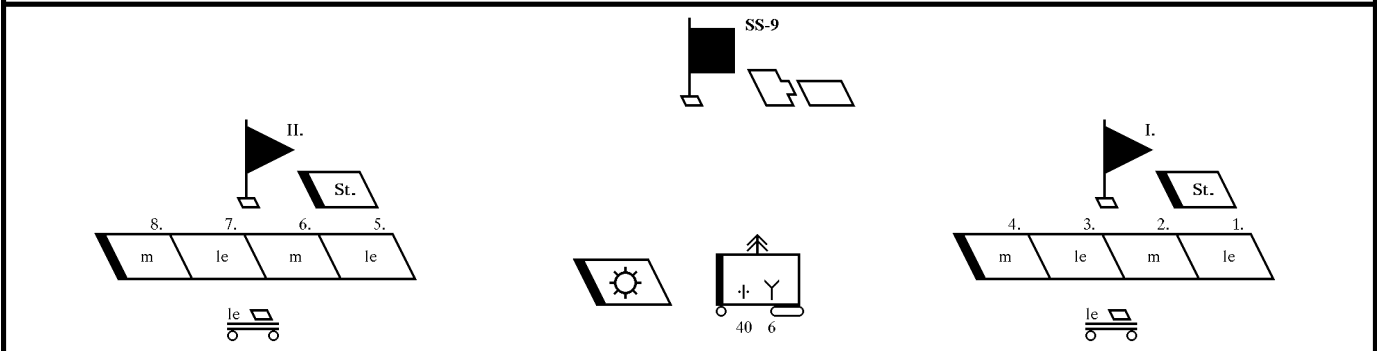
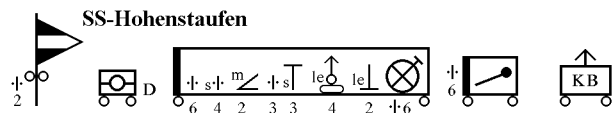

This is the planned organization of SS-Panzergranadier-Division "Karl der Grosse" as of 28.05.1943. The division, never finished organizing in this form, was to be subjected to various changes until it first saw combat in March 1944. It was redesignated as the Panzergranadier Division "Frundsberg" on 3.10.1943.

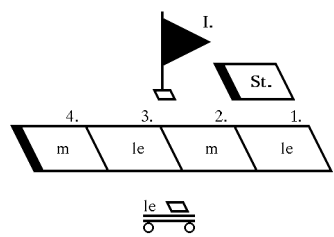
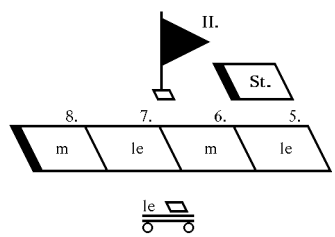
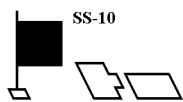
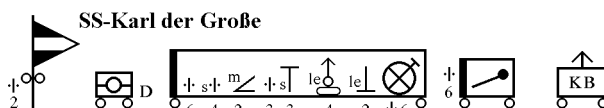

(without one Workshop Platoon) 40 6

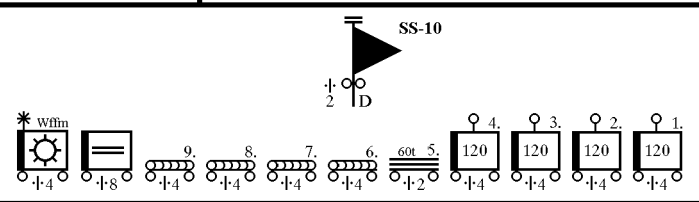
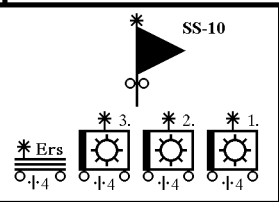
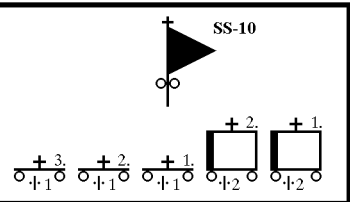
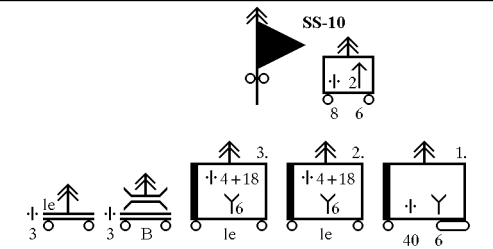
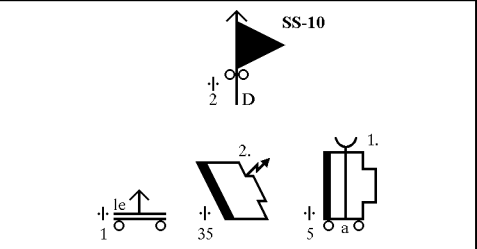
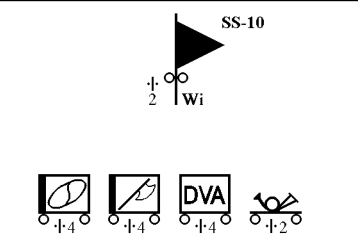
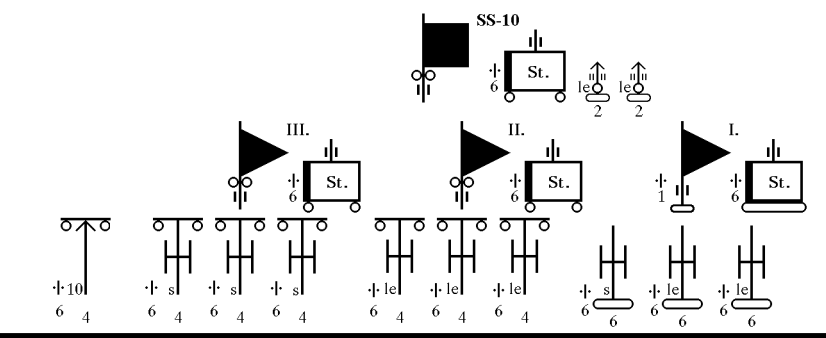
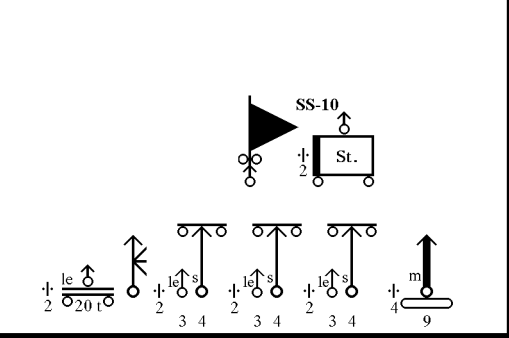
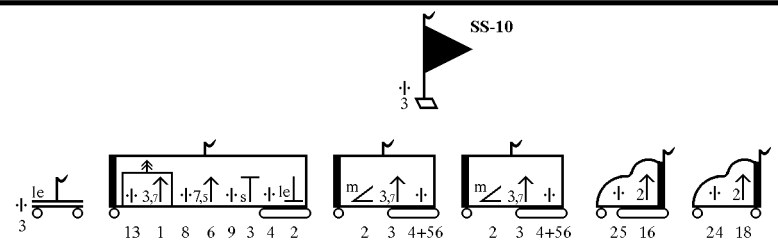
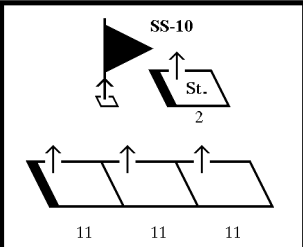
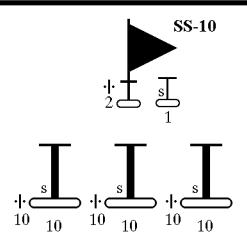
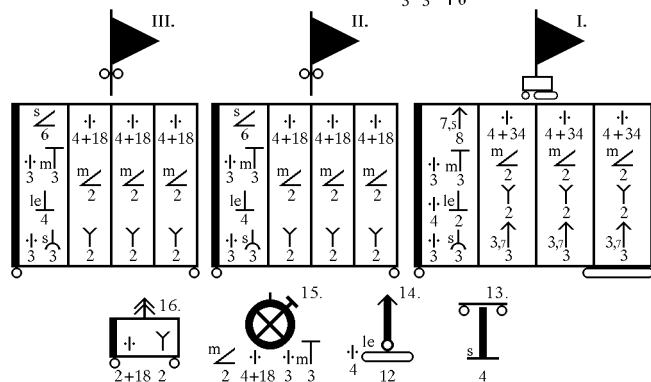
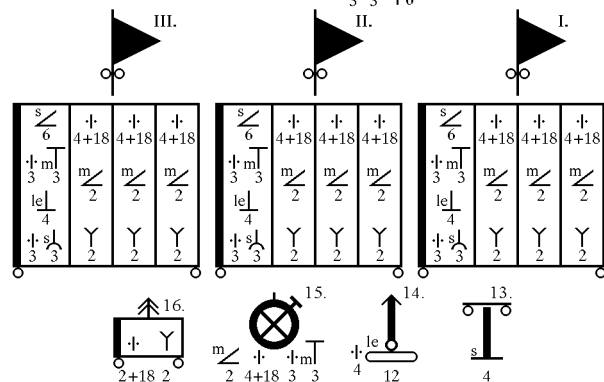
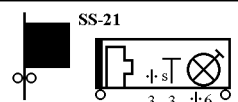
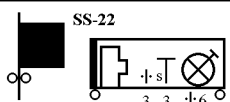

This is the planned organization of the SS-Panzergranadier-Division "Nordland" as of 28.06.1943. The division was never organized in this manner, and was converted to a motorized infantry division later on. It first saw combat in January 1944.

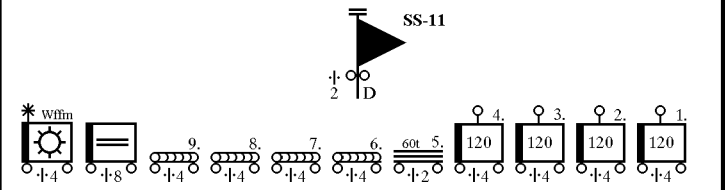
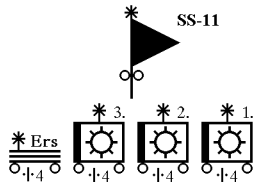
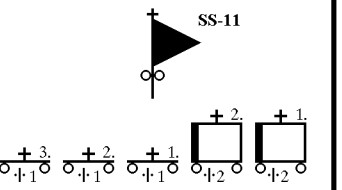
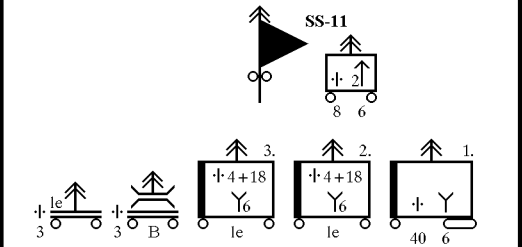
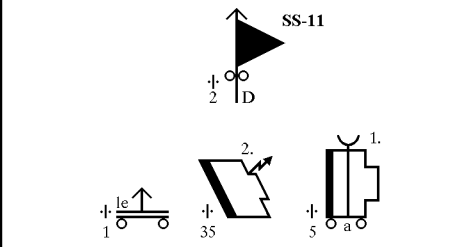
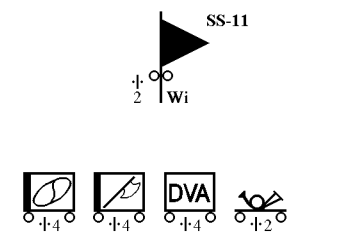
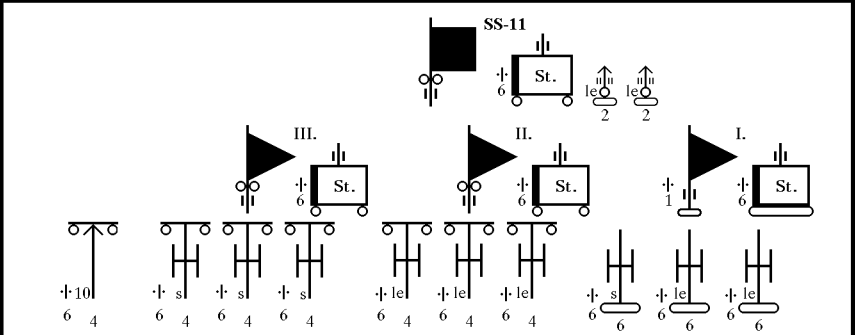
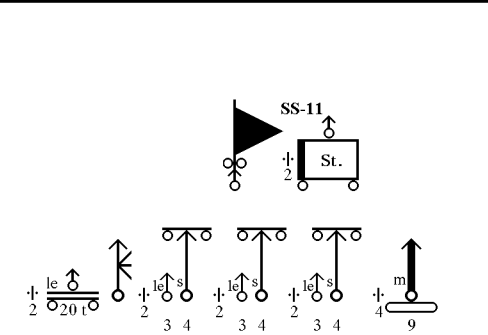
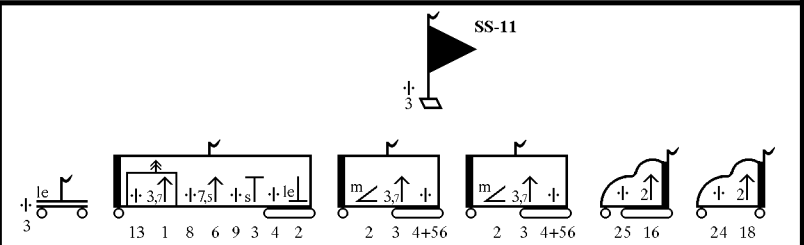
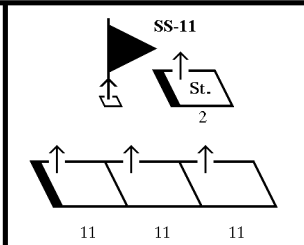
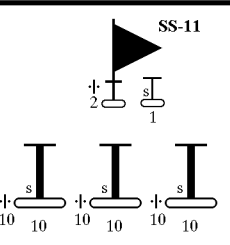
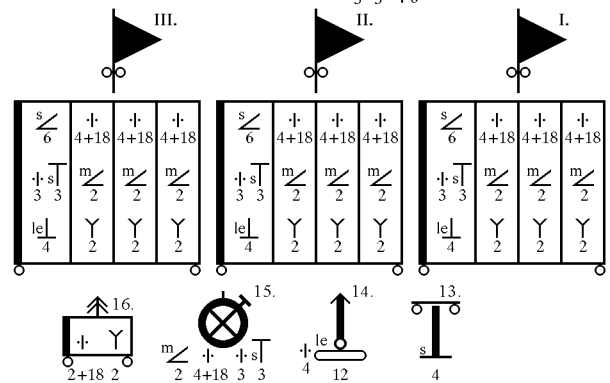
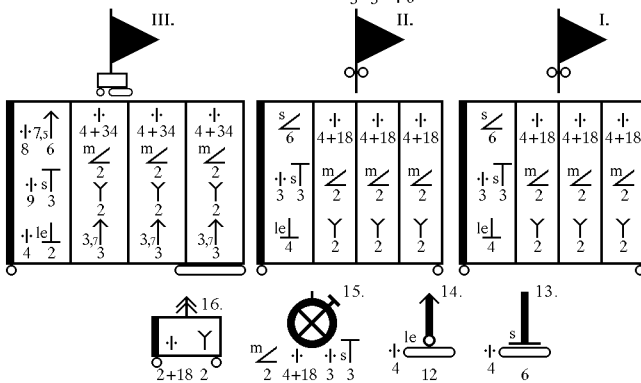
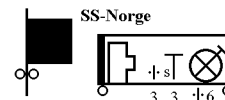
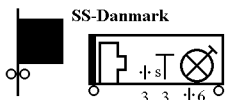
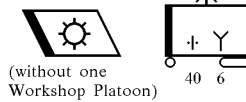
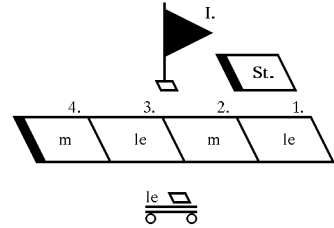
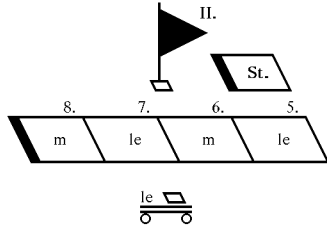
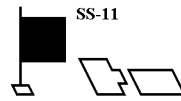
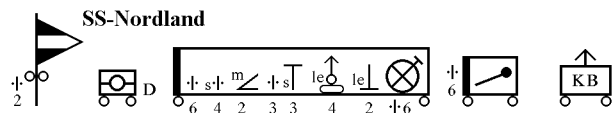

This is the planned organization of the SS-Panzer Grenadier-Division "Hitlerjugend" as of 30.06.1943. The division was organized somewhat differently when it first saw combat in May 1944.

SS-Hitlerjugend

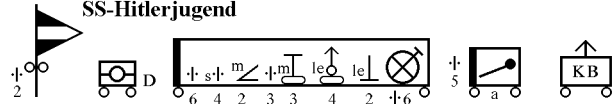

SS-HJ

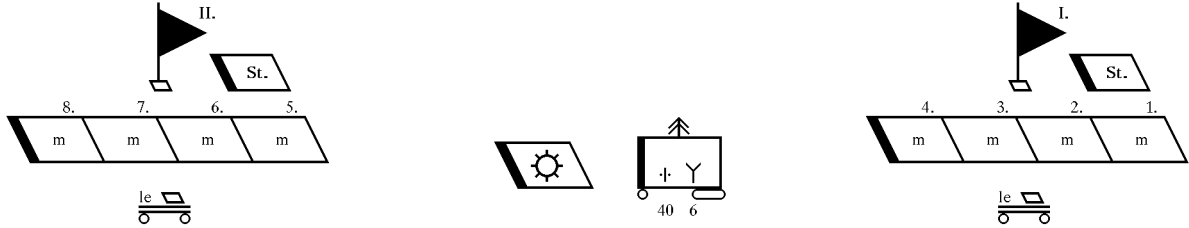

SS-Hitlerjugend-2

SS-Hitlerjugend-1

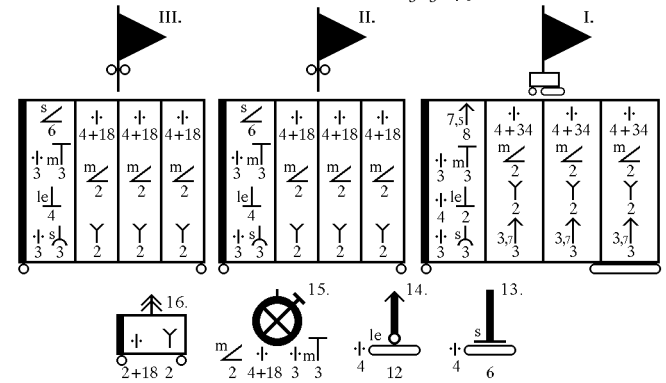
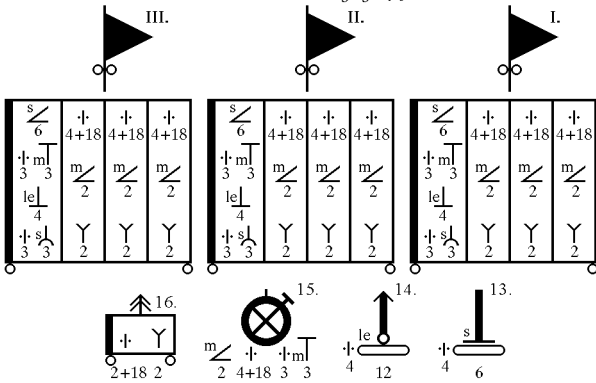

SS-HJ

SS-HJ

SS-HJ

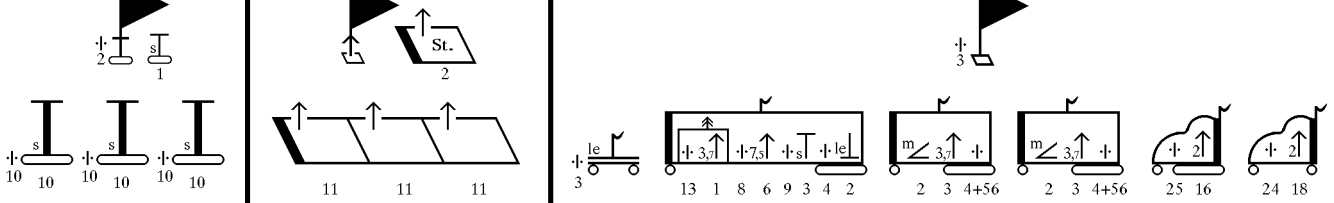

SS-HJ

SS-HJ

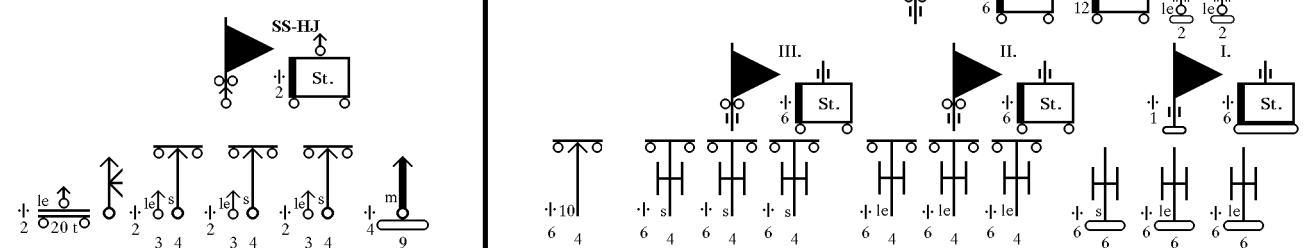

SS-HJ

SS-HJ

SS-HJ

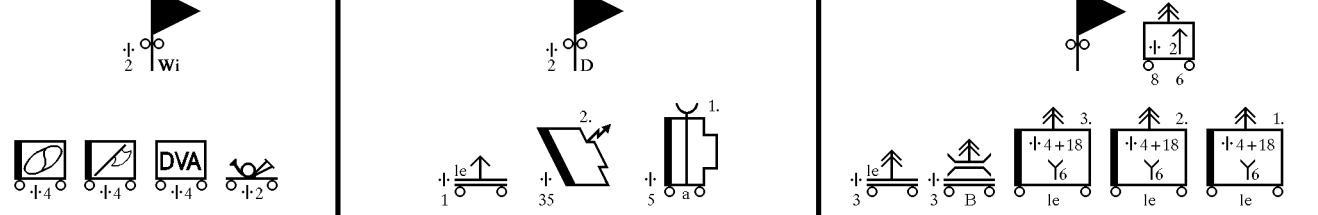

SS-HJ

SS-HJ

SS-HJ

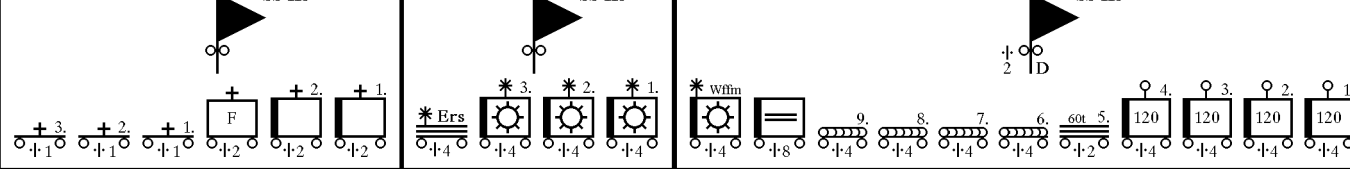

Planned Organization

This is the planned organization of the SS-Freiwilligen-Panzergranadier-Division "Nederland" as of 26.07.1943. Formation was never completed as a division. It was downsized to brigade size in October 1943, and redesignated as the 4. SS-Freiwilligen-Panzergranadier-Brigade "Nederland" on 23.10.1943. It first saw combat in December 1943.

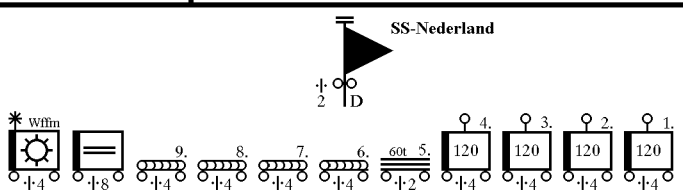
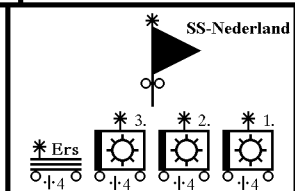
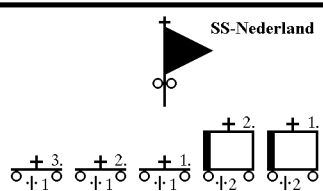
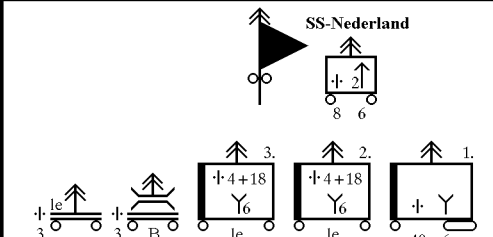
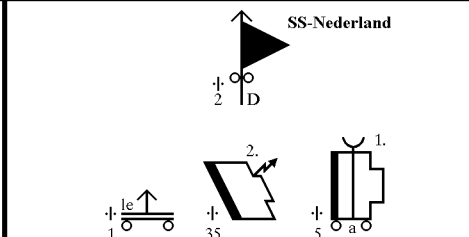
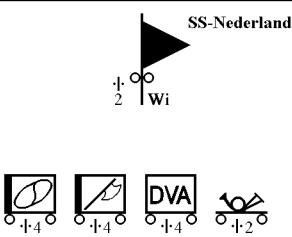
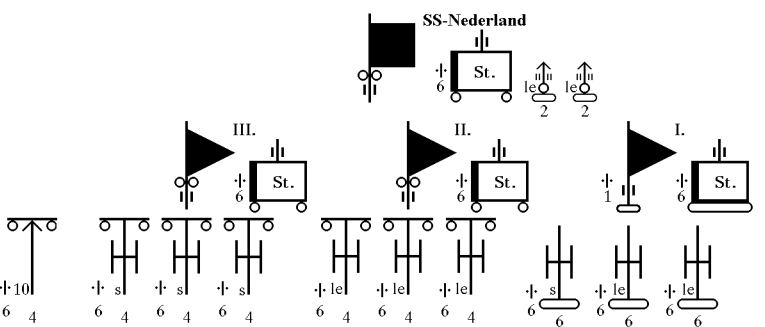
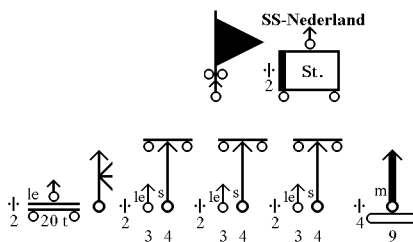
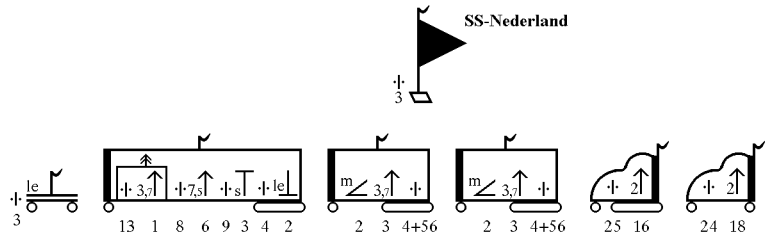
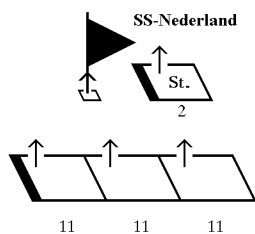
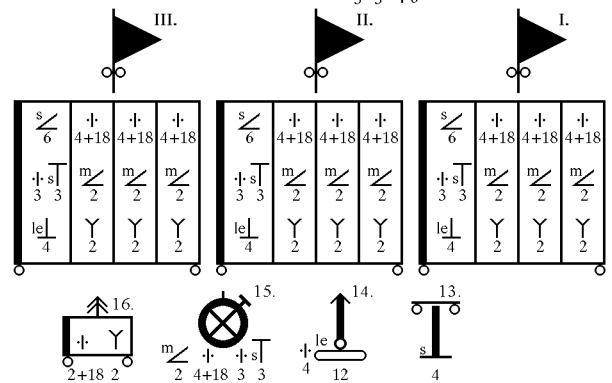
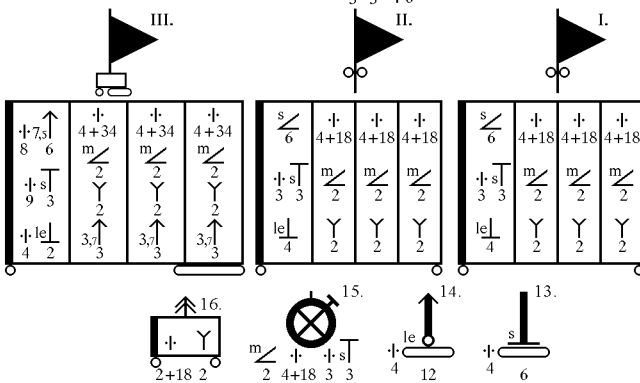
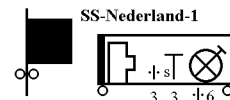
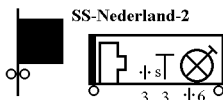
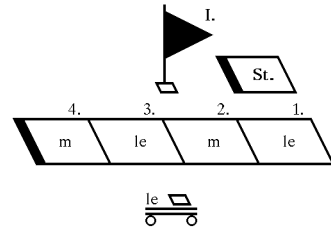
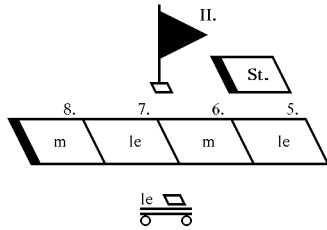
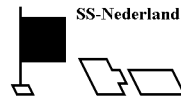
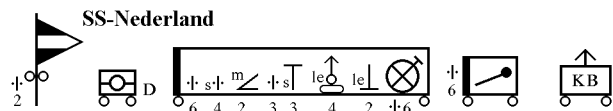

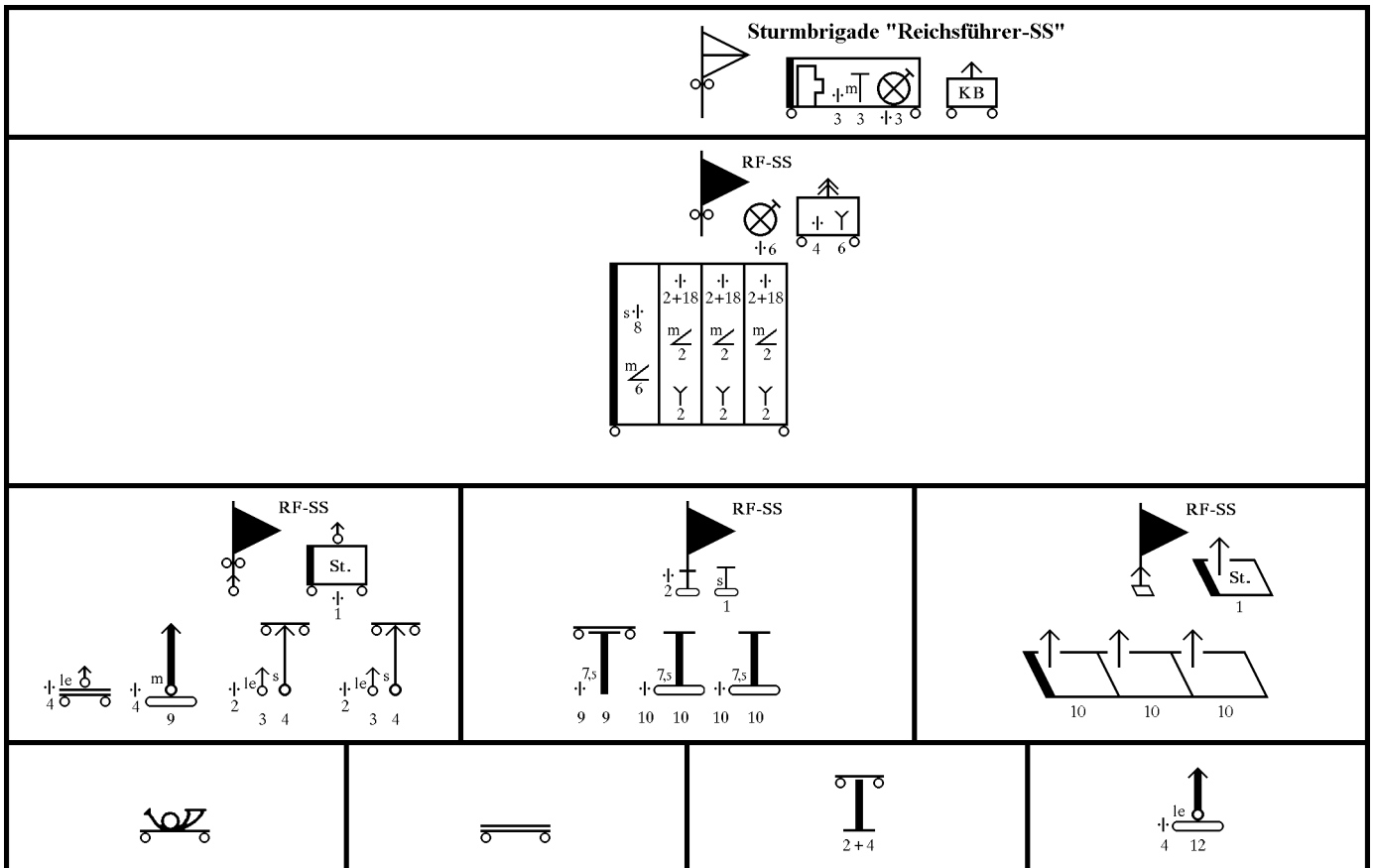

NOTES:

The SS-Sturmbrigade Reichsführer-SS was basically the Begleit-Battalion RF-SS with standard motorized anti-aircraft, self-propelled antitank, and assault gun battalions added.

The SS-Sturmbrigade RF-SS was redesignated as the SS-Panzergranadier Division RF-SS on 3.10.1943, and expanded to division size. On 23.10.1943 it was redesignated as the 16. SS-Panzergranadier Division Reichsführer-SS.

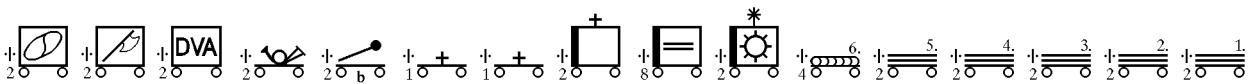
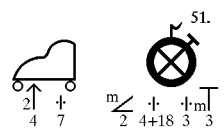
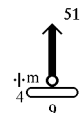
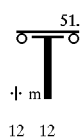
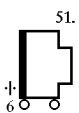
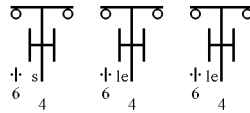
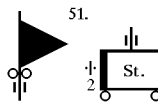
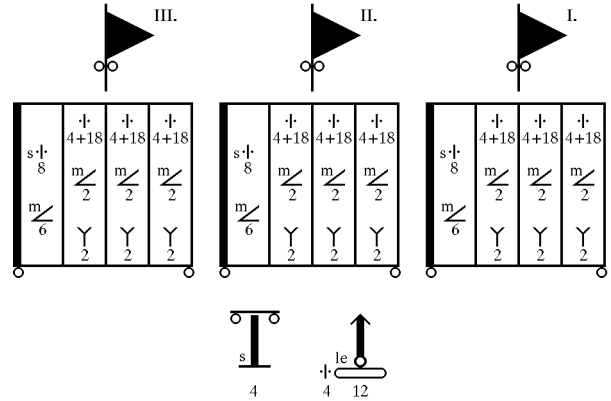
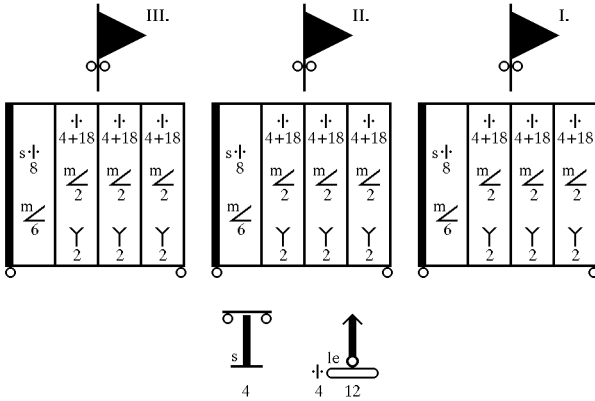
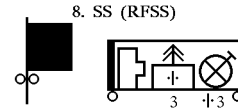
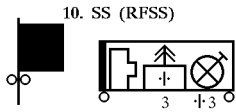
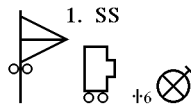

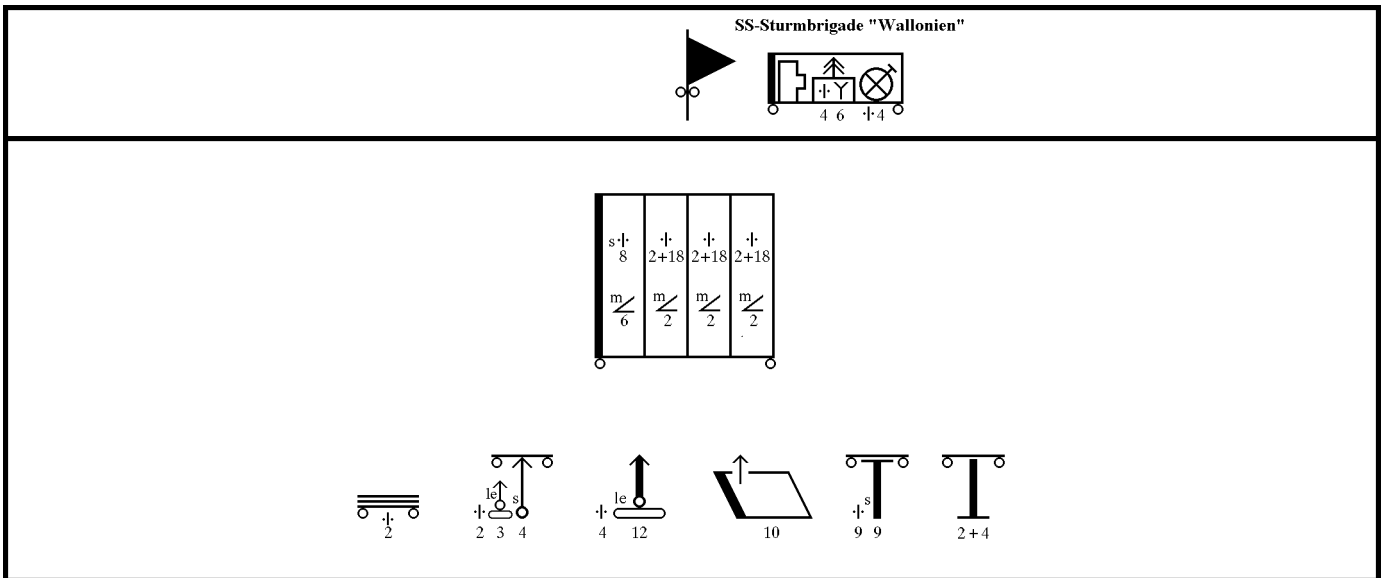

NOTES:

The SS-Sturmbrigade Wallonien had been raised on 01.06.1943, (or better, on that date the Army's 373rd Infantry Battalion manned by Walloons from Belgium was transferred to the Waffen-SS). At the beginning of July 1943 it was still undergoing training at Wildflecken in Germany, remaining there until sent to the front late November 1943. Although already designated as a brigade, the symbol used at this time for the unit was that of a battalion.

SS-Sturmbrigade "Langemarck"

The organizational chart shows a flag on the left and a box on the right containing a building, a mountain, a cross, and a circle with a cross. Below the box are the numbers 4, 6, and 4.

s·t 8	·t 2+18	·t 2+18	·t 2+18
m 6	m 2	m 2	m 2

2

2 3 4

4 12

10

9 9

2+4

NOTES:

The SS-Sturmbrigade Langemarck had been raised on 31.05.1943 from the Volunteer Legion Flanders. At the beginning of July 1943 it was still undergoing training at Heidelager (modern day Debica near Cracow) in Poland, remaining there until sent to the front in January 1944.

**STAB, SS-BRIGADE 1 REICHSFÜHRER-SS (motorisiert)
Headquarters, Motorized SS Infantry Brigade**

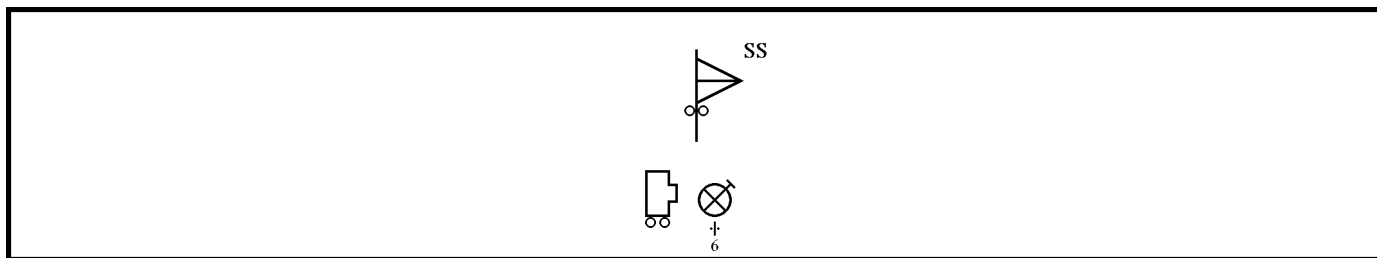

KStN 54 **Headquarters, Motorized Infantry Brigade**
1.11.1941 Brig Hqs: 6 mcl; 4 mcl w/sc; 2 cars (15); 1 car (21).
 Brig Hqs Trains: 2 trucks (2-ton); 1 truck (3-ton).

ex-KStN 1153 **Motorized Signal Platoon**
1.11.1941 Hqs Sect: 1 mcl; 1 mcl w/sc; 1 car (15).
 2 Lt Tele Sect c: 1 car (15).
 2 Lt Radio Sect d: 1 van (17).

ex-KStN 1153 **Motorcycle Platoon**
1.11.1941 Hqs Sect: 3 mcl; 2 cars (15).
 3 Sqd: 4 mcl w/sc; 1 Scout Squad w/ 2 LMG.
 1 Mcl Sect: 8 mcl.

NOTES:

This organization applied for the 1. SS-Brigade (mot).

Formation	Activated	Commanded by	Redesignated on 23.10.1943 as
SS-Brigade 1 Reichsführer-SS	06.1943	SS-Brigadeführer Gottfried Klingeman	1. SS-Infanterie-Brigade (mot)

STAB, SS-PANZER-GRENADIER-DIVISION
Headquarters, Motorized SS Infantry Division

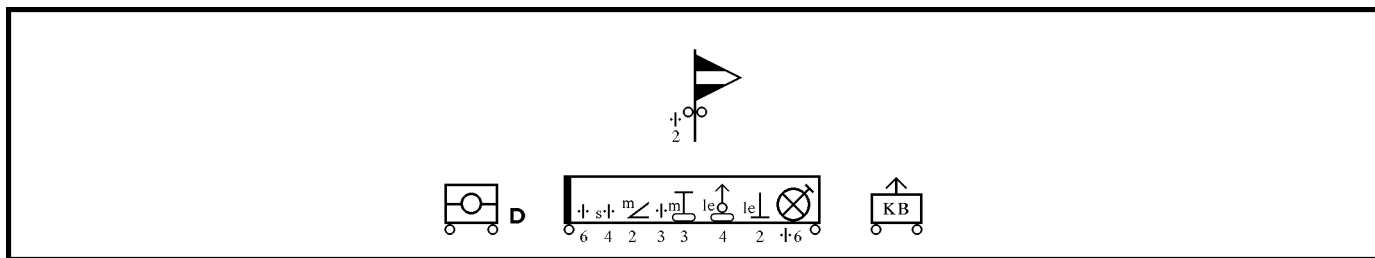
**KStN 51**

1.11.1941

Headquarters, Motorized Infantry Division

Div Hqs: (19 Off; 12 GSO; 29 NCO; 67 EM).

Div Gds: 1 truck (medium); 1 Infantry Squad with 2 LMG.

Mcl Det: Hqs Sect: 5 mcl; 1 mcl w/sc.

5 Sect: 5 mcl; 1 mcl w/sc.

Maint Sect: 1 mcl w/sc; 1 car (2/40).

Motor Pool: 3 mcl; 5 cars (light); 5 cars (medium); 4 cars (15); 1 car (21);

5 trucks (light); 6 trucks (medium); 2 buses (light); 1 bus (medium – converted to office use).

KStN 2076

1.01.1942

Motorized Divisional Mapping Detachment

Det: 1 car (1); 1 bus (medium - converted to office use); 1 van (2-ton).

KStN 1121

1.11.1941

Motorized Divisional Escort Company [1]

Co Hqs: 3 mcl; 2 mcl w/sc; 1 car (15).

Lt Tele Sect c: 1 car (15).

Maint Sect: 1 mcl w/sc; 1 car (2/40).

Co Trains: 1 car (15); 1 truck (2-ton); 2 trucks (medium); 1 truck (3-ton).

ex-KStN 1148a

1.06.1943

ATG Plt: Hqs Sect: 1 mcl; 1 mcl w/sc; 1 car (1); 2 Maultier (3).

Gun Sect: 3 SP'd ATG (76.2mm or 75mm); 3 LMG.

ex-KStN 138c

1.11.1941

Inf Plt: Hqs Sect: 1 mcl; 2 LMG; personnel ride in Infantry Squad trucks.

4 Inf Sqd: 1 truck (medium); 1 Infantry Squad with 1 LMG.

ex-KStN 162

1.02.1941

MG Plt: Hqs Sect: 1 mcl w/sc; 2 cars (15).

2 MG Sect: 1 truck (medium); 2 HMG.

ex-KStN 162

1.02.1941

Mortar Plt: Hqs Sect: 1 mcl; 2 cars (11).

3 Mortar Sect: 1 car (11); 2 trucks (medium); 2 mortars (120mm).

ex-KStN 192(gek)

1.06.1943

SP'd Plt: Hqs Sect: 1 mcl; 2 cars (15); 1 LMG.

Ammo Sect: 2 halftracks (7/1 w/o guns).

Gun Sect: 2 halftracks (7/1 with 20mm Quad Flak).

KStN 1123

1.11.1941

IG Plt: Hqs Sect: 1 mcl; 1 mcl w/sc; 1 truck (69).

Gun Sect: 3 trucks (69); 2 Lt IG (75mm – towed); 1 trailer (ammo).

ex-KStN 1153

1.11.1941

Mcl Plt: Hqs Sect: 3 mcl; 2 cars (15).

3 Sqd: 4 mcl w/sc; 1 Scout Squad w/ 2 LMG.

1 Mcl Sect: 8 mcl.

SS-KStN

1.01.1943

Motorized SS-War Correspondent Platoon

Plt: 4 VW (1); 8 cars (medium); 1 film truck; 1 loudspeaker truck; 2 vans (17); 1 truck (light); 4 trucks (light).

NOTES:

[1] The Divisional Escort Company of the LSSAH and the SS-DR did not have either the mortar platoon or the motorcycle platoon. The SS-W did not have an escort company at this time.

Formation	Activated	Commanded by	Redesignated on 23.10.1943 as
Leibstandarte SS-Adolf Hitler	09.11.1942	SS-Oberführer Thodor Wisch	1. SS-Panzerdivision Leibstandarte SS-Adolf Hitler
SS-Das Reich	09.11.1942	SS-Gruppenführer Walter Krüger	2. SS-Panzerdivision Das Reich
SS-Totenkopf	09.11.1942	SS-Gruppenführer Hermann Preiss	3. SS-Panzerdivision Totenkopf
SS-Polizei	01.06.1943	SS-Gruppenführer Alfred Wünnenberg	4. SS-Polizei-Panzergrenadierdivision
SS-Wiking	09.11.1942	SS-Brigadeführer Herbert Gille	5. SS-Panzerdivision Wiking
SS-Hohenstaufen	01.02.1943	SS-Gruppenführer Wilhelm Bittrich	9. SS-Panzerdivision Hohenstaufen
SS-Karl der Grosse	01.02.1943	SS-Brigadeführer Lothar Debes	10. SS-Panzerdivision Frundsberg
SS-Nordland	01.06.1943	SS-Brigadeführer Friedrich Scholz	11. SS-Panzergrenadierdivision Nordland
SS-Hitlerjugend	01.06.1943	SS-Brigadeführer Fritz Witt	12. SS-Panzerdivision Hitlerjugend
SS-Nederland	18.05.1943	SS-Brigadeführer Jürgen Wagner	4. SS-Freiwilligen-Panzergrenadier-Brigade Nederland

SS-Obersturmbannführer = US Army Lieutenant Colonel
 SS-Oberführer = Senior Colonel (no equivalent rank in US Army)
 SS-Brigadeführer = US Army equivalent is Brigadier General
 SS-Gruppenführer = US Army equivalent is Major General

WAFFEN-SS AFV STRENGTHS ON 30.06.1943
(not including training vehicles)

	Panzer Organization						Tanks, Sturmgeschütz, Command Tanks, and Artillery Tanks											Self-Propelled Antitank Guns					other					
	Pz Rgt	Pz Bn + StuG Bn	Tank Maint.	Flame Plt	Bn. Hqs. Co. Engr. & AA Pfts	Tank Companies StuG lt med hvy		Pz I & II	StuG StuG	Pz-III Flame	<<< medium tanks >>> Pz-III kz	Pz-III 75 ^{mm} lg	Pz-III kz	Pz-IV kz	Pz-IV lg	Pz-VI	Bef-Pz	Beob Pz	Total	75 ^{mm} Pz II	75 ^{mm} Pz 38(t)	75 ^{mm} Lor-raine	76.2 ^{mm} Pz II	76.2 ^{mm} Pz 38(t)	Total	SP'd 105 le	SP'd 150 sFH	SP'd 150 sIG
LSSAH Division	1.SS	I.	1 Co(-)	-	yes	3 - 4 1	On Hand [En-route]	7 [1]	34 [1]	-	3	-	10	-	67	13	9	9	136 [1]	-	20	-	1	-	21 [8]	12	6	12
SS-DR Division	2.SS	II.	1 Co(-)	-	yes	3 3 2 1	On Hand [En-route]	1	34	-	-	-	62	-	33	14	10	9	163	-	-	-	-	9 [4]	9 [4]	12	6	12
SS-T Division	3.SS	I. & II.	1 Co	-	yes	3 2 4 1	On Hand [En-route]	-	27 [8]	-	-	-	63	-	44	15	9	9	167 [8]	11	-	-	-	-	11 [3]	12	6	- [12]
SS-W Division	-	L/5.	1 Co(-)	-	yes	1 2 1 -	On Hand [En-route]	2	6	-	1	8	14	1	16	-	1	-	49	-	10	-	-	-	10 [4]	-	-	-
RFSS Brigade	-	-	-	-	-	- - - -	On Hand [En-route]	-	-	-	-	-	-	-	-	-	-	-	-	-	-	-	-	-	-	-	-	-

NOTES:

1 Co (-) Maintenance Company without one Workshop Platoon.

On Hand vehicles on 30.06.1943, including vehicles awaiting repair.

[En-Route] vehicles allocated to the division on 30.06.1943. However, note that not all these vehicles necessarily arrived on time, and sometimes not even at their scheduled unit.

kz (short) For Pz-III: 50mm L/42
For Pz-IV: 75mm L/24

lg (long) For Pz-III: 50mm L/60
For Pz-IV: 75mm L/43 and L/48

75^{mm} For Pz-III: 75mm L/24

Strengths of Panzer units in the field had little to do with the Authorized (i.e., KStN) strengths. KStN were only adhered to when a unit was rebuilt or initially outfitted. Hence there was a only close relationship between the KStN and the On-Hand strengths when a unit was first sent into battle. Two days later, these KStN were not worth the paper they were written on. Thereafter, the periodic reports submitted by the divisions were used to gauge strength and to decide what replacements – but only in a very general sense – were to be sent to the unit. Until the next time the unit was completely refitted. They did not afford any rights to the unit in the field whatsoever to demand to be filled up to Authorized strength.

Just prior to Kursk, the OKH did attempt to achieve a field strength of approximately 85 medium tanks for each active SS-Panzergeradier division, and only allocated tanks on this basis.

Armored halftracks and armored cars were lumped together with other motor vehicles, and an accurate count was not submitted at this time. Foreign vehicles, such as French, Russian, and other tanks were were not indicated in strength reports.

SS-PANZER-REGIMENT
SS Tank Regiment

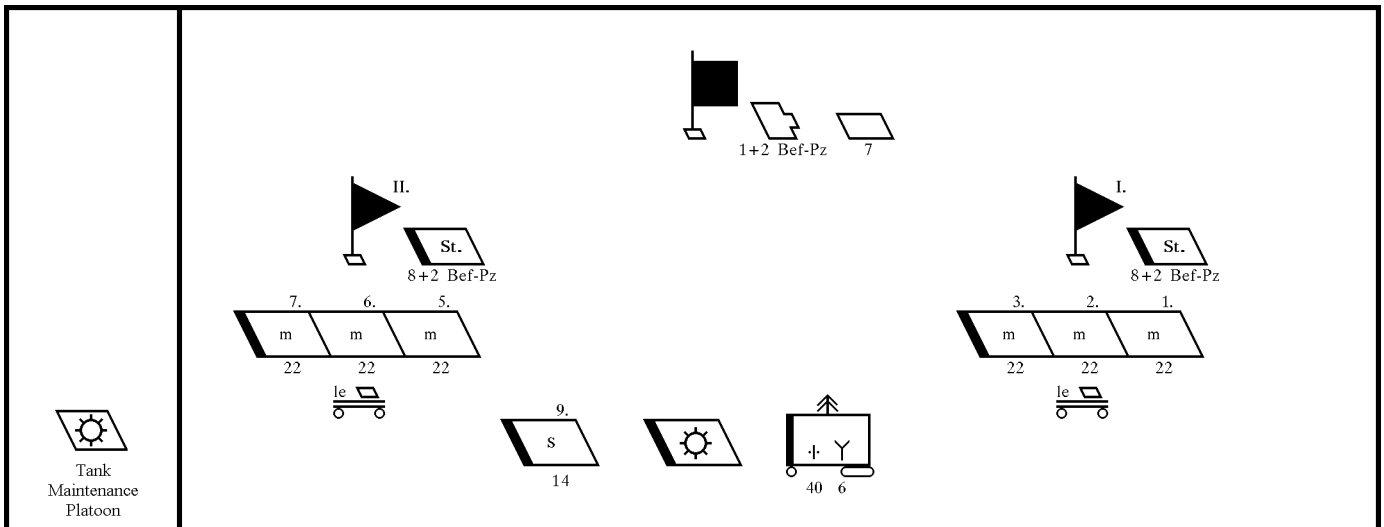

KStN 1103
1.11.1941

Headquarters, Tank Regiment

Rgt Hqs: 4 mcl; 2mcl w/sc; 2 cars (15); 1 car (21).
Recon Plt: 7 medium tanks.
Signal Plt: 1 mcl w/sc; 1 car (15); 1 medium tank; 2 medium command tanks.
Maint Sect: 1 mcl w/sc; 1 car (2/40); 1 truck (3-ton).
Rgt Trains: 2 mcl; 2 cars (1); 3 trucks (light); 2 trucks (2-ton); 5 trucks (3-ton); 1 bus (medium/30 seats).

SSKStN
13.10.1942

SS Armored Combat Engineer Company

Co Hqs: Hqs Sect: 3 mcl; 1 mcl w/sc; 1 car (15); 1 armored halftrack (251).
Equipment Det: 1 truck (2-ton); 2 trucks (3-ton); 1 trailer (bridging materials).
Signal Det: 2 Pack Radio Sect b: 1 car (15).
3 Engr Plt: Hqs Sect: 1 mcl; 1 mcl w/sc; 1 SPW (250/3); 1 truck (2-ton).
3 Engr Sect: 2 armored halftracks (251/7); 1 Combat Engineer Section with 2 LMG.
Co Maint Sect: 1 mcl w/sc; 1 car (2/40); 1 truck (medium).
Co Trains: 1 mcl w/sc; 3 trucks (medium); 1 truck (3-ton).

KStN 1187
1.06.1942

Motorized Tank Maintenance Company

Co Hqs: 1 mcl; 1 mcl w/sc; 1 car (light); 1 car (1); 1 truck (medium); 1 AA car (4 w/ dual MG).
2 Workshop Plt: 7 trucks (3-ton); 2 trucks (4.5-ton); 2 vans (4.5-ton); 1 bus (medium/22 seats);
1 trailer (generator - A); 1 trailer (arc welding); 2 LMG.
Recovery Plt: 2 mcl w/sc; 1 car (1); 1 motor crane (100 - 3-ton); 1 halftrack crane (9/1 - 6-ton); 2 halftracks (7); 6 halftracks (9);
2 trailers (10-ton/tank - *Sd.Ah. 115*); 4 trailers (22-ton/tank - *Sd.Ah. 116*).
Armorer Sect: 1 mcl w/sc; 1 car (15); 4 trucks (medium).
Signal Maint Sect: 1 truck (2-ton); 2 vans (42); 1 trailer (generator - *Sd.Ah. 23*).
Co Trains: 1 mcl w/sc; 1 car (light); 4 trucks (medium).

KStN 1185
1.06.1942

Motorized Tank Maintenance Platoon

Plt Hqs: 1 mcl w/sc; 1 car (1).
Workshop Det: 9 trucks (3-ton); 1 van (79); 1 bus (medium/22 seats); 1 trailer (generator - A); 1 trailer (arc welding); 2 LMG.
Signal Maint Sect: 1 truck (light); 2 vans (42); 1 trailer (generator - *Sd.Ah. 23*).
Recovery Det: 1 mcl w/sc; 1 car (1); 1 motor crane (3-ton capacity); 1 halftrack (7); 3 halftracks (9); 1 halftrack crane (9/1 - 6-ton capacity);
1 trailer (10-ton/tank - *Sd.Ah. 115*); 2 trailer (22-ton/tank - *Sd.Ah. 116*).
Armorer Sect: 1 mcl w/sc; 1 car (15); 2 trucks (medium).
Signal Maint Sect: 1 truck (2-ton); 2 vans (42); 1 trailer (generator - *Sd.Ah. 23*).
Plt Trains: 1 mcl w/sc; 1 car (light); 3 trucks (medium).

KStN 1107
1.04.1943

Headquarters, Tank Battalion

Bn Hqs: 2 mcl; 3 VW (1); 3 cars (15); 1 truck (2-ton).

KStN 1150b
25.01.1943

Headquarters Company, Medium Tank Battalion

Co Hqs: 2 mcl; 1 car (15).
Recon Plt: 7 medium tanks.
Signal Plt: 1 mcl; 1 car (15); 1 medium tank; 2 medium command tanks.
Scout Plt: Hqs Sect: 3 mcl; 1 VW (1).
4 Sect: 3 mcl; 1 VW (1); 1 LMG.
Co Maint Sect: 1 VW (1); 1 car (2/40); 1 truck (3-ton); 1 truck (4.5-ton).
Co Trains: 2 cars (1); 3 trucks (3-ton); 1 truck (4.5-ton); 1 LMG.
Medic Sect: 1 VW (1); 1 car (medium); 2 trucks (3-ton); 1 ambulance (31); 1 SPW (251/8).
Bn Admin Det: 3 cars (1); 2 trucks (3-ton); 30 trucks (4.5-ton); 1 LMG.

KStN 1190
25.01.1943

Flame-Throwing Tank Platoon

Plt: 7 Flamm-Pz-III (141).

KStN 1183(Sd)
1.02.1941

Motorized Light Transport Column, Tank Battalion

Col Hqs: 1 mcl; 1 mcl w/sc; 1 car (15).
3 Sect: 1 mcl; 8 trucks (2-ton).
Col Maint Sect: 1 mcl w/sc; 1 car (2/40).
Col Trains: 2 trucks (light).

KStN 1175a
25.01.1943

Medium Tank Company

Co Hqs: 4 mcl; 1 car (15); 2 medium tanks.
4 Tank Plt: 5 medium tanks.
Maint Sect: 1 VW (1); 1 car (2/40); 1 truck (3-ton); 1 truck (4.5-ton); 2 halftracks (10).
Co Trains: 3 VW (1); 2 trucks (medium); 2 trucks (3-ton); 2 trucks (4.5-ton).

KStN 1176e
5.03.1943

Heavy Tank Company (Tiger)

Co Hqs: 3 mcl; 1 mcl w/sc; 1 car (15); 2 Pz-VI (181).
3 Plt: 4 Pz-VI (181).
Co Maint Sect: 3 VW (1); 1 car (2/40); 1 truck (3-ton); 1 truck (4.5-ton); 1 halftrack (10).
Co Trains: 1 mcl w/sc; 2 VW (1); 2 trucks (3-ton); 6 trucks (4.5-ton); 1 LMG.

NOTES:

The 25.01.1943 KStN eliminated light and medium tank companies. Although on 15.03.1943 all combat tanks were defined as being medium, many companies continued to have had a mixed composition, continuing with the old classifications of companies until the new KStN was implemented. The Pz-II, used for reconnaissance, were replaced by medium tanks when they were lost. Medium tanks could be Pz-III with short and long 50mm guns, as well as short 75mm guns (*Sd.Kfz. 141* and *141/1*), or Pz-IV with short and long 75mm guns (*Sd.Kfz. 161*, *161/1*, and *161/2*).

The LSSAH, SS-DR, and SS-T Panzer Regiments each had one heavy Tank Company and one SS Armored Combat Engineer Company.

Only the II./LSSAH Panzer Regiment had a Flame-Throwing Tank Platoon.

A Panther tank battalion equipped with Pz-V's (*Sd.Kfz. 171*) was being raised for each of the LSSAH, SS-DR, and SS-W Panzer Regiments in the West at this time.

The SS-W had a tank maintenance platoon instead of a company. The Regimental Headquarters for the SS-W Panzer Regiment was being raised in the West.

For tank strengths on 30.06.1943, see page 47.

SS-STURMGESCHÜTZ-ABTEILUNG
SS Assault Gun Battalion

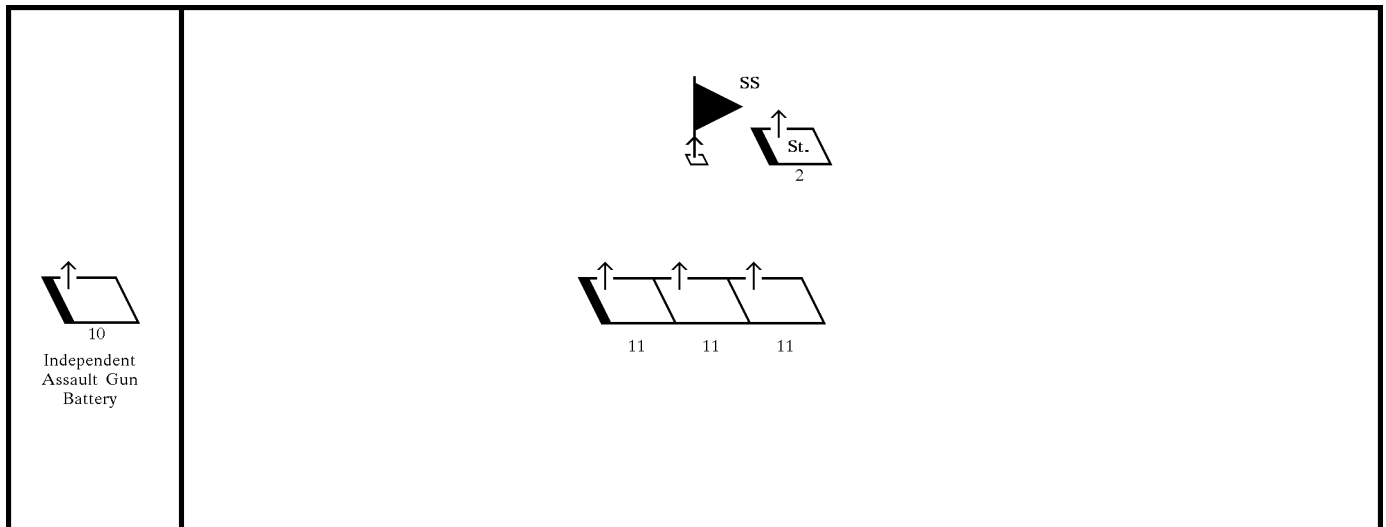

KStN 416
1.12.1942

Headquarters, Assault Gun Battalion

Bn Hqs: 4 mcl; 2 mcl w/sc; 2 cars (15); 1 van (17); 1 ambulance (31); 1 Sturmgeschütz III (142/1).

KStN 588a
1.11.1942

Headquarters Battery, Assault Gun Battalion

Bty Hqs: 1 mcl; 1 car (15).

Bty Trains: 2 cars (light); 1 AA car (4 w/dual MG); 6 trucks (3-ton).

Battalion Maintenance Det:

Ordnance & Signal Maint Sect: 1 car (light); 2 trucks (3-ton).

Motor Maint Sect: 1 mcl; 1 mcl w/sc; 1 car (medium); 1 bus (medium/22 seats); 8 trucks (3-ton); 1 van (79);
1 trailer (generator - A); 1 trailer (arc welding).

Recovery Sect: 2 halftracks (9); 1 motor crane (100 – 3-ton capacity); 2 trailers (22-ton tank - *Sd.Ah. 116*).

KStN 446a
1.11.1942

Assault Gun Battery

Bty Hqs: 3 mcl; 1 mcl w/sc; 1 car (15); 1 Sturmgeschütz III (142/1).

2 Lt Radio Sect *b*: 1 van (17).

3 AG Plt: Hqs Sect: 2 mcl w/sc.

Ammo Sect: 2 trucks (3-ton); 1 trailer (ammo - *Sd.Ah. 31/I*).

Gun Sect: 3 Sturmgeschütz III (142/1) or 3 Sturmhaubitze III (142/2).

Maint Sect: 2 mcl w/sc; 3 trucks (3-ton).

Bty Trains: 1 mcl; 1 car (1); 1 AA car (4 w/ dual MG); 14 trucks (3-ton).

KStN 446a
1.11.1942

Independent Assault Gun Battery

Bty Hqs: 3 mcl; 1 mcl w/sc; 1 car (15); 2 Sturmgeschütz III (142/1).

2 Lt Radio Sect *b*: 1 van (17).

3 AG Plt: Hqs Sect: 2 mcl w/sc.

Ammo Sect: 2 trucks (3-ton); 1 trailer (ammo - *Sd.Ah. 31/I*).

Gun Sect: 3 Sturmgeschütz III (142/1) or 3 Sturmhaubitze III (142/2).

Maint Sect: 2 mcl w/sc; 4 trucks (3-ton); 1 halftrack (9); 1 trailer (22-ton tank - *Sd.Ah. 116*).

Bty Trains: 1 mcl; 1 car (1); 1 AA car (4 w/ dual MG); 15 trucks (3-ton).

Formation	On Hand	Authorized			
		Headquarters	1st Battery	2nd Battery	3rd Battery
LSSAH	(35 StuG)	2 StuG III	11 StuG III	11 StuG III	11 StuG III
SS-DR	(34 StuG)	2 StuG III	11 StuG III	11 StuG III	11 StuG III
SS-T	(35 StuG)	2 StuG III	11 StuG III	11 StuG III	11 StuG III
SS-W	(9 or 6 StuG*)	–	10 StuG III	–	–
RFSS Brig	–	1 StuG III	10 StuG III	10 StuG III	10 StuG III

Notes:

The three Waffen-SS Panzergrenadier Divisions were authorized additional Sturmgeschütz, one in the battalion headquarters, and another in each battery headquarters, for a total per battalion of 35 Sturmgeschütz.

* The '9' comes from the divisional status report of 1.07.43, the '6' from the Sturmgeschütz aggregate for the same date.

LSSAH-PANZERGRENADIER-REGIMENT
LSSAH Infantry Regiment

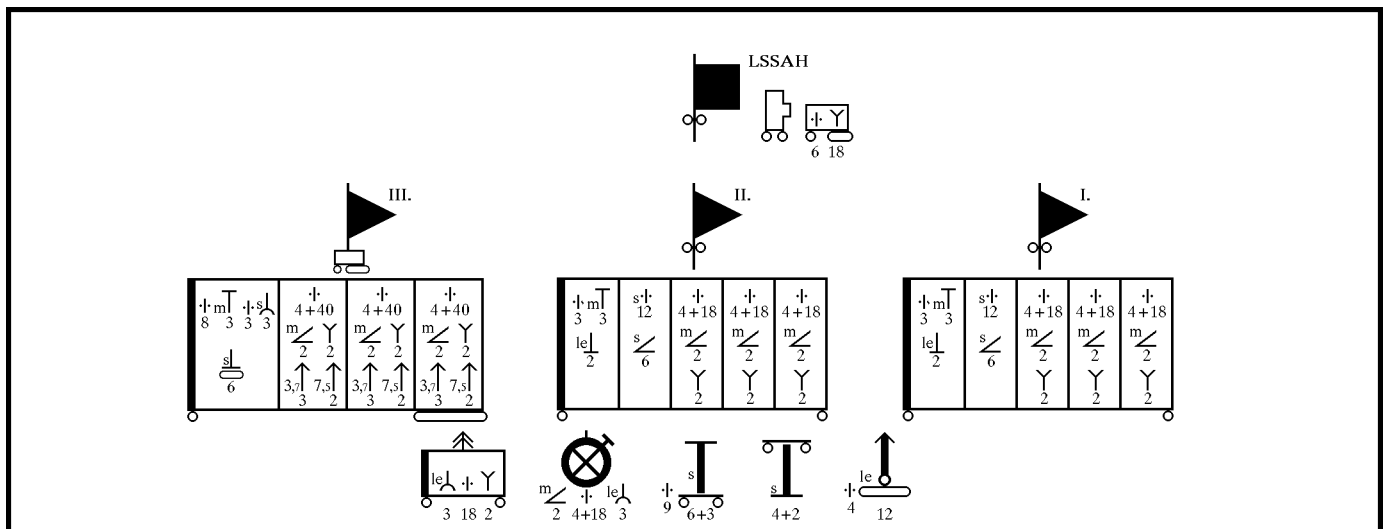

KStN 103c
1.11.1941
(modified)

Headquarters, Infantry Regiment (motorized)

Rgt Hqs: 5 mcl; 2 mcl w/sc; 2 cars (12); 1 car (medium).
Maint Sect: 1 mcl w/sc; 1 car (2/40).
Trains: 1 mcl; 2 cars (light); 2 cars (medium); 4 trucks (light); 3 trucks (medium); 1 bus (medium/33 seats).

ex- KStN 129
1.11.1941

Signal Platoon: Hqs Sect: 1 mcl; 1 mcl w/sc; 3 cars (15).
2 Lt Tele Sect *d*: 1 car (15).
4 Pack Radio Sect *d*: ride in Headquarters Section vehicles.
4 Lt Radio Sect *e*: 1 van (17).

KStN 1130
20.01.1943

Flame Platoon: Hqs Sect: 1 mcl w/sc; 3 Maultier (3).
Flame Sect: 6 SPW (251/16).

KStN 192
1.02.1941

Self-Propelled Antiaircraft Company

Co Hqs: 4 mcl; 1 car (1); 1 car (15); 1 LMG.
Signal Det: Hqs Sect: 1 car (15).
1 Lt Tele Sect *c*: 1 car (15).
4 Pack Radio Sect *b*: 1 car (2).
3 AA Plt: Hqs Sect: 3 mcl; 2 cars (15); 1 LMG.
Gun Sect: 4 halftracks (10/4 with 20mm Flak); 2 halftracks (10/4 without guns); 4 trailers (antiaircraft- *Sd.Ah. 51*).
Co Maint Sect: 1 mcl w/sc; 1 car (2/40); 1 truck (medium).
Co Trains: 3 mcl; 1 mcl w/sc; 1 car (15); 2 trucks (light); 2 trucks (2-ton); 2 trucks (3-ton).

KStN 174
1.12.1942
(modified)

Infantry Gun Company (motorized) / Grossdeutschland

Co Hqs: 5 mcl; 2 mcl w/sc; 2 cars (15).
Signal Det: 2 Lt Tele Sect *d*: 1 car (15).
2 Pack Radio Sect *d*: 1 car (2).
1 Lt IG Plt: Hqs Sect: 1 mcl; 1 mcl w/sc; 1 car (12).
Gun Sect: 6 cars (12); 4 trailers (ammo - *Sd.Ah. 32*); 2 light infantry guns (75mm - towed).
2 Hvy IG Plt: Hqs Sect: 1 mcl; 1 mcl w/sc; 1 car (12).
1 Lt Tele Sect *d*: 1 car (15).
Gun Sect: 4 halftracks (10); 2 trailers (ammo - *Sd.Ah. 32*); 2 heavy infantry guns (150mm - towed).
Co Maint Sect: 1 mcl w/sc; 1 car (2/40).
Co Trains: 1 car (light); 1 truck (light); 1 truck (medium); 2 trucks (3-ton).

KStN 1140
1.04.1943

Motorized Antitank Company

Co Hqs: 3 mcl; 1 mcl w/sc; 1 car (15).
1 AT Plt: Hqs Sect: 1 mcl; 1 mcl w/sc; 1 car (12).
Gun Sect: 5 trucks (69); 3 antitank guns (37mm - towed); 2 LMG.
2 AT Plt: Hqs Sect: 1 mcl; 1 mcl w/sc; 1 car (1).
Gun Sect: 5 halftracks (11); 3 heavy antitank guns (75mm or 76.2mm - towed); 3 LMG.
Co Maint Sect: 1 mcl w/sc; 1 car (2/40).
Co Trains: 1 car (light); 1 truck (light); 1 truck (medium); 4 trucks (1½-ton).

KStN 1112
1.11.1941

Motorcycle Infantry Company

Co Hqs: 4 mcl; 2 mcl w/sc; 1 car (15).
3 Mcl Plt: Hqs Sect: 1 mcl; 2 cars (15).
3 Mcl Sect: 4 mcl w/sc; 1 Infantry Squad with 2 LMG.
1 Hvy Plt: Hqs Sect: 1 mcl; 1 mcl w/sc; 2 cars (15).
2 HMG Sect: 8 mcl w/sc; 2 HMG.
1 Mortar Sect: 3 trucks (70); 2 mortars (81mm).
Maint Sect: 1 mcl w/sc; 1 car (2/40);
Co Trains: 1 car (15); 1 truck (2-ton); 2 trucks (medium); 1 truck (3-ton).

KStN 1127
1.11.1942

Antitank Rifle Section: 1 mcl w/sc; 3 trucks (70); 3 ATR (28mm - towed on *Sd.Ah. 32/3*).

KStN 714
1.04.1943

Motorized Light Combat Engineer Company

Co Hqs: 3 mcl; 1 mcl w/sc; 1 car (15).
Support Det: 1 truck (1.5-ton); 2 trucks (3-ton).
Signal Det: Hqs Sect: 1 car (15).
2 Lt Radio Sect *e*: 1 van (17).
3 CE Plt: Hqs Sect: 1 mcl; 1 mcl w/sc; 1 car (15); 1 truck (1.5-ton); 1 ATR.
3 Engr Sect: 2 trucks (1.5-ton); 1 Combat Engineer Section with 2 LMG.
Maint Sect: 1 mcl w/sc; 1 car (2/40).
Co Trains: 1 mcl w/sc; 2 trucks (medium); 1 truck (3-ton).

LSSAH-PANZERGRENADIER-REGIMENT
LSSAH Infantry Regiment

KStN 115c

1.11.1941

Headquarters, Infantry Battalion (motorized)

Bn Hqs: 4 mcl; 2 mcl w/sc; 1 car (1); 3 cars (15).
Signal Det: Hqs Sect: 1 car (15); 1 truck (2-ton).
2 Lt Tele Sect *d*: ride in Headquarters Section truck (2-ton).
2 Pack Radio Sect *d*: ride in Headquarters Section truck (2-ton).
2 Pack Radio Sect *d*: 1 car (2).
Bn Hqs Trains: 1 mcl w/sc; 1 car (light); 1 truck (light); 2 trucks (medium); 1 ambulance (31).
Bn Maint Det: 1 mcl w/sc; 1 car (2/40); 1 car (light); 1 truck (light); 2 trucks (3-ton).
Bn Trains: 1 mcl; 3 cars (light); 3 trucks (medium); 6 trucks (3-ton).

KStN 1114

1.11.1941

Motorized Infantry Company

Co Hqs: 3 mcl; 2 mcl w/sc; 1 car (15).
3 Inf Plt: Hqs Sect: 1 mcl; 1 car (15).
3 Inf Sqd: 2 trucks (70); 1 Infantry Squad w/ 2 LMG.
1 Hvy Plt: Hqs Sect: 1 mcl; 1 mcl w/sc; 1 car (15).
2 HMG Sect: 2 trucks (70); 2 HMG.
1 Mortar Sect: 3 trucks (70); 2 mortars (81mm).
Maint Sect: 1 mcl w/sc; 1 car (2/40).
Co Trains: 1 car (15); 1 truck (2-ton); 1 truck (medium); 1 truck (3-ton).

KStN 162

1.02.1941

Machine Gun Company (motorized)

Co Hqs: 4 mcl; 3 cars (15).
3 MG Plt: Hqs Sect: 1 mcl w/sc; 2 cars (15).
2 MG Sect: 1 truck (medium); 2 HMG.
1 Mortar Plt: Hqs Sect: 1 mcl; 2 cars (11).
3 Mortar Sect: 1 car (11); 2 trucks (medium); 2 mortars (120mm).
Maint Sect: 1 mcl w/sc; 1 car (2/40).
Co Trains: 2 mcl; 1 mcl w/sc; 1 car (light); 3 trucks (light); 1 truck (medium).

KStN 163

1.03.1943

Heavy Company (motorized)

Co Hqs: 4 mcl; 1 mcl w/sc; 1 car (15).
Signal Det: 1 Lt Tele Sect *d*: 1 car (15).
2 Pack Radio Sect *d*: 1 car (2).
ATG Plt: Hqs Sect: 1 mcl; 1 mcl w/sc; 1 car (12).
Gun Sect: 5 halftracks (10); 3 ATG (50mm – towed); 2 trailers (ammo); 3 LMG.
Lt IG Plt: Hqs Sect: 1 mcl; 1 mcl w/sc; 1 halftrack (10); 1 LMG.
Gun Sect: 3 halftracks (10); 2 Lt IG (75mm – towed); 1 trailer (ammo).
Maint Sect: 1 mcl w/sc; 1 car (2/40).
Co Trains: 2 mcl; 1 mcl w/sc; 1 car (light); 1 truck (light); 3 trucks (medium); 1 truck (3-ton).

KStN 1108a(gp)

1.04.1943

Headquarters, Armored Infantry Battalion

Co Hqs: 5 mcl; 1 mcl w/sc; 3 VW (1); 1 car (medium); 2 SPW (251/3); 1 SPW (251/8).
Signal Det: Hqs Sect: 1 SPW (251/11).
1 Med Armd Tele Sect: 1 SPW (251/11).
2 Armd Pack Radio Sect *g*: ride together in one SPW (250/3).
2 Armd Pack Radio Sect *g*: ride together in one SPW (250/3).
Co Maint Sect: 1 VW (2/40); 1 truck (3-ton); 1 halftrack (7).
Co Trains: 3 VW (1); 2 trucks (medium); 4 trucks (3-ton); 1 ambulance (31).
Bn Maint Det: 3 VW (1); 5 trucks (3-ton); 1 van (3-ton); 1 halftrack (7); 1 trailer (generator - *Sd.Ah.* 23); 1 trailer (generator - *A*).
Bn Supply Det: 1 mcl; 1 VW (1); 5 trucks (3-ton).

KStN 1114c(gp)

1.04.1943

Armored Infantry Company

Co Hqs: 3mcl; 1 mcl w/sc; 2 SPW (251/3).
3 Inf Plt: Hqs Sect: 1 mcl; 1 SPW (251/10 with 37mm ATG).
3 Inf Sqd: 1 SPW (251/1); 1 Infantry Squad w/ 2 LMG.
1 Hvy Plt: Hqs Sect: 1 mcl; 1 mcl w/sc; 1 SPW (251/1).
2 HMG Sect: 1 SPW (251/1); 2 HMG.
1 Mortar Sect: 2 SPW (251/2 with 81mm mortar).
1 Gun Sect: 2 SPW (251/9).
Maint Sect: 1 VW (2/40); 1 truck (3-ton); 1 halftrack (7).
Co Trains: 1 VW (1); 1 truck (medium); 3 trucks (3-ton).

Armored Heavy Company**KStN 1121a(gp)**

1.03.1943

Co Hqs: 2 mcl; 2 mcl w/sc; 1 SPW (251/3).
Lt Armd Tele Sect *c*: 1 SPW (251/11).
Maint Sect: 1 VW (1); 2 trucks (3-ton); 1 halftrack (8).
Co Trains: 1 car (15); 2 trucks (medium); 4 trucks (3-ton).

KStN 1122a(gp)

1.12.1941

ATG Plt: Hqs Sect: 1 mcl; 1 mcl w/sc; 1 SPW (250/1).
Gun Sect: 4 SPW (251/1); 3 ATG (50mm-towed); 3 LMG.

KStN 1127(gp)

1.11.1941

ATG Sect: 1 mcl w/sc; 3 SPW (250/11 with 28mm ATG).

Improvised unit

Self-Propelled Infantry Gun Platoon: 6 SP'd 150mm IG (138/1).

NOTES:

Only the Panzergrenadier-Regiment LSSAH 2 had the flame platoon equipped with armored halftracks. The headquarters companies of both regiments had been dissolved, the engineer and antitank platoons being transferred to the regimental

companies. The engineer companies were furthermore made up of the platoons taken out of the heavy companies. The administrative and service elements were controlled directly by the regimental headquarters.

Division	Regiment	I. Battalion	II. Battalion	III. Battalion	IG Company	AA Company	AT Company	Mcl Company	Engineer Company
LSSAH	LSSAH 1	motorized	motorized	motorized	16th (mot)	17th (SP'd)	18th (mot)	19th	20th (motorized)
	LSSAH 2	motorized	motorized	armored	15th (mot)	16th (SP'd)	17th (mot)	18th	19th (motorized)

SS-PANZERGRENADIER-REGIMENT
SS Infantry Regiment

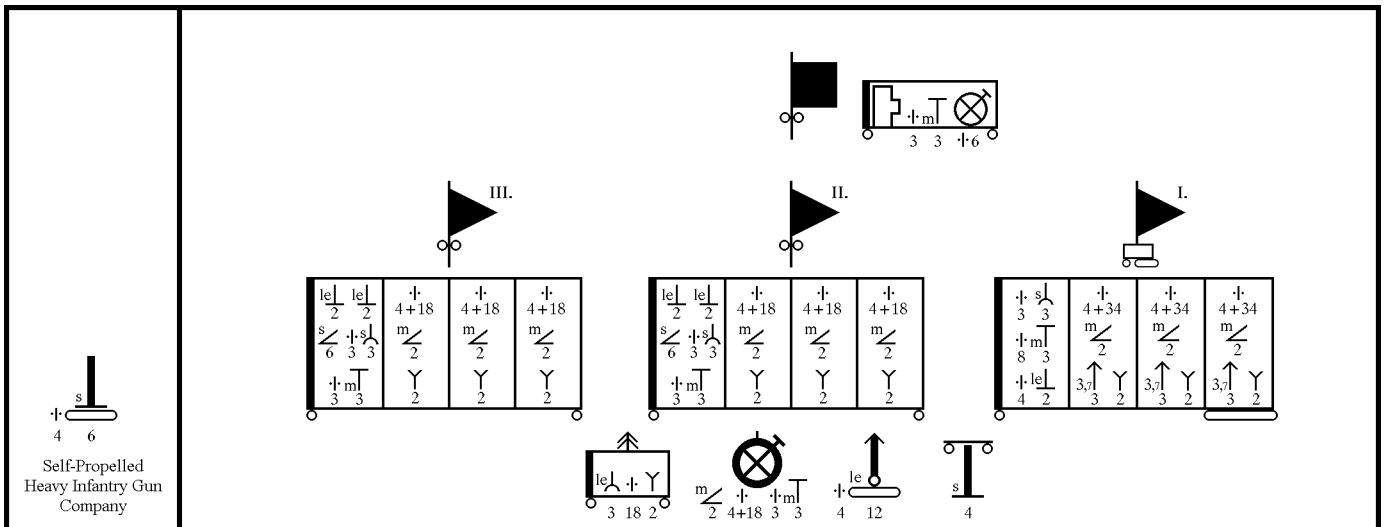

KStN 1104
1.11.1941

Headquarters, Motorized Infantry Regiment
Rgt Hqs: 4 mcl; 2 mcl w/sc; 3 cars (15).

KStN 1153
1.11.1941

Headquarters Company, Motorized Infantry Regiment

Co Hqs: 2 mcl; 2 mcl w/sc; 1 car (15).

Mcl Plt: Hqs Sect: 3 mcl; 2 cars (15).

3 Sqd: 4 mcl w/sc; 1 Scout Squad w/ 2 LMG.

ATG Plt: Hqs Sect: 1 mcl; 1 mcl w/sc; 1 halftrack (10).

Gun Sect: 4 halftracks (10); 3 ATG (50mm – towed); 1 trailer (ammo); 3 LMG.

Signal Plt: Hqs Sect: 1 mcl; 1 mcl w/sc; 1 car (15).

1 Lt Tele Sect c: 1 car (15).

4 Pack Radio Sect b: 1 car (2).

2 Lt Armd Radio Sect d: 1 AC (261).

Maint Sect: 1 mcl w/sc; 1 car (2/40); 1 car (light); 2 trucks (3-ton).

Co Trains: 1 mcl; 3 cars (light); 1 car (15); 2 trucks (light); 4 trucks (medium); 1 bus (medium/33 seats).

KStN 1120
1.11.1941

Motorized Heavy Infantry Gun Company

Co Hqs: 3 mcl; 2 mcl w/sc; 2 halftracks (10).

2 Lt Tele Sect c: ride in one of the company headquarters's halftracks.

2 IG Plt: Hqs Sect: 1 mcl; 1 mcl w/sc; 1 halftrack (10).

Gun Sect: 4 halftracks (10); 2 heavy infantry guns (150mm - towed); 2 trailers (ammo - *Sd.Ah.* 32).

Co Maint Sect: 1 mcl w/sc; 1 car (2/40).

Co Trains: 1 car (15); 1 truck (2-ton); 2 trucks (medium); 1 truck (3-ton).

KStN 1120a
1.05.1943

Self-Propelled Heavy Infantry Gun Company

Co Hqs: 4 mcl; 1 mcl w/sc; 1 SPW (251/1); 1 Maultier (3).

3 Hvy IG Plt: Hqs Sect: 1 mcl; 1 mcl w/sc; 1 SPW (251/3).

Gun Sect: 1 VW (1); 2 SP'd 150mm IG (138/1); 2 Maultier (3); 3 trailers (ammo); 1 LMG.

Ammo Det: 3 Maultier (3); 3 trailers (ammo).

Maint Sect: 1 car (2/40); 2 trucks (3-ton); 1 halftrack (8).

Co Trains: 1 VW (1); 1 truck (light); 1 truck (medium); 4 trucks (3-ton).

KStN 192(gek)
1.06.1943

Mechanized Light Anti-Aircraft Company

Co Hqs: 2 mcl; 1 car (15); 1 LMG.

Signal Det: Hqs Sect: 1 car (15).

1 Lt Tele Sect c: 1 car (15).

3 Pack Radio Sect b: 1 car (2).

3 Mono SP'd Plt: Hqs Sect: 1 mcl; 2 cars (15); 1 LMG.

Ammo Sect: 2 halftracks (10/4 w/o guns).

Gun Sect: 4 halftracks (10/4 with 20mm Flak).

Maint Sect: 1 car (2/40); 1 truck (medium).

Co Trains: 1 mcl w/sc; 1 car (15); 2 trucks (light); 2 trucks (1.5-ton); 2 trucks (3-ton).

KStN 1112
1.11.1941

Motorcycle Infantry Company

Co Hqs: 4 mcl; 2 mcl w/sc; 1 car (15).

3 Mcl Plt: Hqs Sect: 1 mcl; 2 cars (15).

3 Mcl Sect: 4 mcl w/sc; 1 Infantry Squad with 2 LMG.

1 Hvy Plt: Hqs Sect: 1 mcl; 1 mcl w/sc; 2 cars (15).

2 HMG Sect: 8 mcl w/sc; 2 HMG.

1 Mortar Sect: 3 trucks (70); 2 mortars (81mm).

Maint Sect: 1 mcl w/sc; 1 car (2/40);

Co Trains: 1 car (15); 1 truck (2-ton); 2 trucks (medium); 1 truck (3-ton).

KStN 1122a
1.12.1941

Antitank Platoon: Hqs Sect: 1 mcl; 1 mcl w/sc; 1 car (15).

Gun Sect: 5 halftracks (10); 3 ATG (50mm – towed); 2 trailers (ammo); 3 LMG.

KStN 714
1.04.1943

Motorized Light Combat Engineer Company

Co Hqs: 3 mcl; 1 mcl w/sc; 1 car (15).

Support Det: 1 truck (1.5-ton); 2 trucks (3-ton).

Signal Det: Hqs Sect: 1 car (15).

2 Lt Radio Sect e: 1 van (17)

3 CE Plt: Hqs Sect: 1 mcl; 1 mcl w/sc; 1 car (15); 1 truck (1.5-ton); 1 ATR.

3 Engr Sect: 2 trucks (1.5-ton); 1 Combat Engineer Section with 2 LMG.

Maint Sect: 1 mcl w/sc; 1 car (2/40).

Co Trains: 1 mcl w/sc; 2 trucks (medium); 1 truck (3-ton).

SS-PANZERGRENADEIER-REGIMENT
SS Infantry Regiment

- KStN 1108**
1.11.1941 **Headquarters, Motorized Infantry Battalion**
Bn Hqs: 5 mcl; 2 mcl w/sc; 4 cars (15).
Signal Det: Hqs Sect: 1 car (15).
1 Lt Tele Sect c: 1 car (15).
2 Pack Radio Sect d: 1 car (2).
2 Lt Radio Sect d: 1 van (17).
Bn Hqs Trains: 1 mcl w/sc; 1 car (15); 1 truck (2-ton); 1 truck (medium); 1 truck (3-ton); 1 ambulance (31).
Bn Maint Det: 1 mcl w/sc; 1 car (2/40); 1 car (light); 3 trucks (3-ton).
Bn Trains: 1 mcl; 3 cars (light); 8 trucks (3-ton).
- KStN 1114**
1.11.1941 **Motorized Infantry Company**
Co Hqs: 3 mcl; 2 mcl w/sc; 1 car (15).
3 Inf Plt: Hqs Sect: 1 mcl; 1 car (15).
3 Inf Sqd: 2 trucks (70); 1 Infantry Squad w/ 2 LMG.
1 Hvy Plt: Hqs Sect: 1 mcl; 1 mcl w/sc; 1 car (15).
2 HMG Sect: 2 trucks (70); 2 HMG.
1 Mortar Sect: 3 trucks (70); 2 mortars (81mm).
Maint Sect: 1 mcl w/sc; 1 car (2/40).
Co Trains: 1 car (15); 1 truck (2-ton); 1 truck (medium); 1 truck (3-ton).
- KStN 1121**
1.11.1941 **Motorized Heavy Company**
Co Hqs: 3 mcl; 2 mcl w/sc; 1 car (15).
Lt Tele Sect c: 1 car (15).
Maint Sect: 1 mcl w/sc; 1 car (2/40).
Co Trains: 1 car (15); 1 truck (2-ton); 2 trucks (medium); 1 truck (3-ton).
- KStN 1122a**
1.12.1941 **ATG Plt: Hqs Sect: 1 mcl; 1 mcl w/sc; 1 car (15).**
Gun Sect: 5 halftracks (10); 3 ATG (50mm – towed); 2 trailers (ammo); 3 LMG.
- KStN 1123**
1.11.1941 **2 Lt IG Plt: Hqs Sect: 1 mcl; 1 mcl w/sc; 1 truck (69).**
Gun Sect: 3 trucks (69); 2 lt IG (75mm – towed); 1 trailer (ammo).
- KStN 1127**
1.11.1941 **ATG Sect: 1 mcl; 3 trucks (1.5-ton); 2 ATG (28mm cone-bore – towed); 3 LMG.**
- ex-KStN 162**
1.02.1941 **Mortar Plt: Hqs Sect: 1 mcl; 2 cars (11).**
3 Mortar Sect: 1 car (11); 2 trucks (medium); 2 mortars (81mm).
- KStN 1108a(gp)**
1.04.1943 **Headquarters, Armored Infantry Battalion**
Co Hqs: 5 mcl; 1 mcl w/sc; 3 VW (1); 1 car (medium); 2 SPW (251/3); 1 SPW (251/8).
Signal Det: Hqs Sect: 1 SPW (251/11).
1 Med Armd Tele Sect: 1 SPW (251/11).
2 Armd Pack Radio Sect g: ride together in one SPW (250/3).
2 Armd Pack Radio Sect g: ride together in one SPW (250/3).
Co Maint Sect: 1 VW (2/40); 1 truck (3-ton); 1 halftrack (7).
Co Trains: 3 VW (1); 2 trucks (medium); 4 trucks (3-ton); 1 ambulance (31).
Bn Maint Det: 3 VW (1); 5 trucks (3-ton); 1 van (3-ton); 1 halftrack (7); 1 trailer (generator - *Sd.Ah.* 23); 1 trailer (generator - A).
Bn Supply Det: 1 mcl; 1 VW (1); 5 trucks (3-ton).
- KStN 1114(gp)**
1.11.1941 **Armored Infantry Company**
Co Hqs: 3mcl; 1 mcl w/sc; 2 SPW (250/3).
3 Inf Plt: Hqs Sect: 1 mcl; 1 SPW (251/10 with 37mm ATG).
3 Inf Sqd: 1 SPW (251/1); 1 Infantry Squad w/ 2 LMG.
1 Hvy Plt: Hqs Sect: 1 mcl; 1 mcl w/sc; 1 SPW (251/1).
2 HMG Sect: 1 SPW (251/1); 2 HMG.
1 Mortar Sect: 2 SPW (251/2 with 81mm mortar).
Maint Sect: 1 mcl w/sc; 1 car (2/40).
Co Trains: 1 car (15); 1 truck (2-ton); 1 truck (medium); 1 truck (3-ton).
- KStN 1121a(gp)**
1.11.1941 **Armored Heavy Company**
Co Hqs: 2 mcl; 2 mcl w/sc; 1 SPW (250/3).
Lt Armd Tele Sect c: 1 SPW (250/2).
Maint Sect: 1 mcl w/sc; 1 car (2/40).
Co Trains: 1 car (15); 1 truck (2-ton); 2 trucks (medium); 1 truck (3-ton).
- KStN 1122a(gp)**
1.12.1941 **ATG Plt: Hqs Sect: 1 mcl; 1 mcl w/sc; 1 SPW (250/1).**
Gun Sect: 4 SPW (251/1); 3 ATG (50mm-towed); 3 LMG.
- KStN 1123(gp)**
1.11.1941 **IG Plt: Hqs Sect: 1 mcl; 1 mcl w/sc; 1 SPW (250/1).**
Gun Sect: 3 SPW (251/4); 2 lt IG (75mm - towed).
- KStN 1125(gp)**
1.05.1943 **Gun Plt: Hqs Sect: 1 mcl w/sc; 1 SPW (251/3);**
Gun Sect: 6 SPW (251/9).
Ammo Det: 1 SPW (251/4); 1 truck (3-ton)..
- KStN 1127(gp)**
1.11.1941 **ATG Sect: 1 mcl w/sc; 3 SPW (250/11 with 28mm ATG).**

Formation	Regiment	I. Battalion	II. Battalion	III. Battalion	IG Company	AA Company	AT Company	Mcl Company	Engineer Company
SS-DR	SS-Deutschland	mot	mot	mot	13th (SP'd)	14th (SP'd)	–	15th	16th (mot)
	SS-Der Führer	mot	mot	armored	13th (SP'd)	14th (SP'd)	–	15th	16th (mot)
SS-T	SS-Thule	armored	mot	mot	13th (mot)	14th (SP'd)	–	15th	16th (mot)
	SS-Theodor Eicke	mot	mot	mot	13th (mot)	14th (SP'd)	–	15th	16th (mot)
SS-W	SS-Westland	mot	mot	mot	13th (mot)	–	–	–	–
	SS-Germania	mot	mot	mot	13th (mot)	–	–	–	–
1. SS Brig	8. SS (RF-SS)	mot	mot	mot	13th (mot)	14th (SP'd)	–	–	–
	10. SS (RF-SS)	mot	mot	mot	13th (mot)	14th (SP'd)	–	–	–

STURMBRIGADE REICHSFÜHRER-SS
Assault Brigade Reichsführer-SS

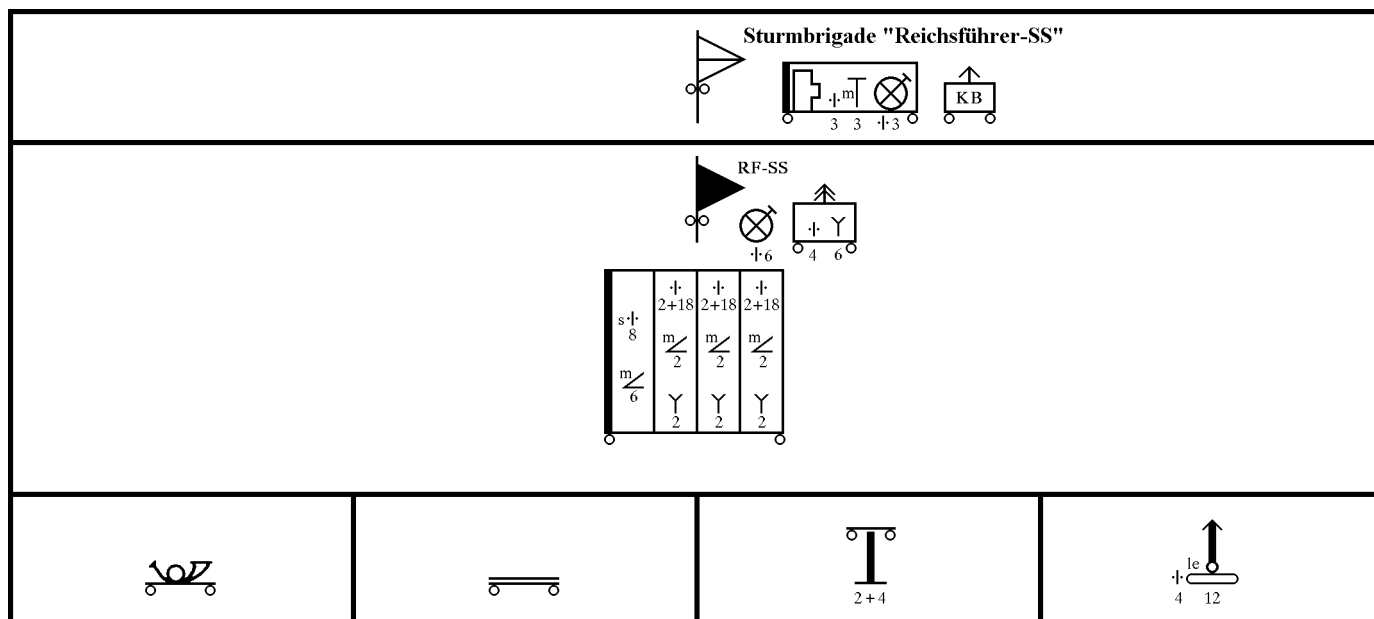

KStN 114
1.10.1942

Headquarters, Führer Escort Battalion

Bn Hqs: 2 mcl w/sc; 3 cars (medium); 1 Volkswagen; 6 cars (15); 2 trucks (medium).

KStN 129
1.11.1941

Headquarters Company, Infantry Regiment (motorized)

Co Hqs: 2 mcl; 2 mcl w/sc; 1 car (12)
 MotorcyclePlt: Hqs Sect: 1 mcl; 2 cars (15).
 3 Recon Sqd: 1 mcl; 4 mcl w/sc; 1 Reconnaissance Squad with 1 LMG.
 1 Messenger Sect: 8 mcl.
 Anti-Tank Plt: Hqs Sect: 1 mcl; 1 mcl w/sc; 1 halftrack (10); 3 LMG..
 Gun Sect: 4 halftracks (10); 3 ATG (50mm – towed); 1 trailer (ammo).
 Signal Plt: Hqs Sect: 1 mcl; 1 mcl w/sc; 3 cars (15).
 2 Lt Tele Sect *d*: 1 car (15).
 4 Pack Radio Sect *d*: ride in Headquarters Section vehicles.
 4 Lt Radio Sect *e*: 1 van (17).
 Maint Sect: 1 mcl w/sc; 1 car (2/40).
 Co Trains: 1 mcl; 3 cars (light); 4 trucks (light); 2 trucks (medium); 1 bus (medium/33 seats).

SS KStN
1.01.1943

Motorized War Correspondent PLatoon

Plt: 4 cars (light-cc); 8 cars (medium); 1 film equipment van; 1 loudspeaker van; 2 recording equipment vans (17); 1 truck (light); 4 trucks (medium).

KStN 1108
1.11.1941

Headquarters, Motorized Infantry Battalion

Bn Hqs: 5 mcl; 2 mcl w/sc; 4 cars (15).
 Signal Det: Hqs Sect: 1 car (15).
 1 Lt Tele Sect *c*: 1 car (15).
 2 Pack Radio Sect *d*: 1 car (2).
 2 Lt Radio Sect *d*: 1 van (17).
 Bn Hqs Trains: 1 mcl w/sc; 1 car (15); 1 truck (2-ton); 1 truck (medium); 1 truck (3-ton); 1 ambulance (31).
 Bn Maint Det: 1 mcl w/sc; 1 car (2/40); 1 car (light); 3 trucks (3-ton).
 Bn Trains: 1 mcl; 2 cars (light); 7 trucks (3-ton).

ex KStN 1153
1.11.1941

Motorcycle Platoon

Hqs Sect: 3 mcl; 2 cars (15).
 3 Sqd: 4 mcl w/sc; 1 Scout Squad w/ 2 LMG.

KStN 1124
1.11.1941

Motorized Engineer Platoon

Hqs Sect: 1 mcl; 1 mcl w/sc; 1 car (15); 2 trucks (2-ton).
 4 Engr Sect: 1 truck (2-ton); 1 Engineer Section w/ 1 LMG.

KStN 1114
1.11.1941

Motorized Infantry Company, Motorized Infantry Battalion

Co Hqs: 3 mcl; 2 mcl w/sc; 1 car (15).
 3 Inf Plt: Hqs Sect: 1 mcl; 1 car (15).
 3 Inf Sqd: 2 trucks (70); 1 Infantry Squad w/ 2 LMG.
 1 Hvy Plt: Hqs Sect: 1 mcl; 1 mcl w/sc; 1 car (15).
 2 HMG Sect: 2 trucks (70); 2 HMG.
 1 Mortar Sect: 3 trucks (70); 2 mortars (81mm).
 Maint Sect: 1 mcl w/sc; 1 car (2/40).
 Co Trains: 1 car (15); 1 truck (2-ton); 1 truck (medium); 1 truck (3-ton).

KStN 162
1.02.1941

Machine Gun Company (motorized)

Co Hqs: 1 mcl; 4 mcl; 2 mcl w/sc; 3 cars (15).
 2 MG Plt: Hqs Sect: 1 mcl w/sc; 2 cars (15).
 2 MG Sect: 1 truck (medium); 2 HMG.
 1 Mortar Plt: Hqs Sect: 1 mcl; 2 cars (11).
 3 Mortar Sect: 2 trucks (medium); 2 mortars (81mm).
 Maint Sect: 1 mcl w/sc; 1 car (2/40).
 Co Trains: 2 mcl; 1 mcl w/sc; 1 car (light); 3 trucks (light); 1 truck (medium).

STURMBRIGADE REICHSFÜHRER-SS
Assault Brigade Reichsführer-SS

KStN 1741.12.1942
(modified)**Infantry Gun Company (motorized) / Grossdeutschland**

Co Hqs: 5 mcl; 2 mcl w/sc; 2 cars (15).
 2 Lt Tele Sect *d*: 1 car (15).
 2 Pack Radio Sect *d*: 1 car (2).
 2 Lt IG Plt: Hqs Sect: 1 mcl; 1 mcl w/sc; 1 car (15).
 Gun Sect: 6 cars (12); 2 infantry guns (75mm – towed); 4 trailers (ammo - *Sd.Ah.* 32).
 1 Hvy IG Plt: Hqs Sect: 1 mcl; 1 mcl w/sc; 1 car (15).
 Lt Tele Sect *d*: 1 car (15).
 Gun Sect: 4 halftracks (1); 2 infantry guns (150mm – towed); 2 trailers (ammo - *Sd.Ah.* 32).
 Main Sect: 1 mcl w/sc; 1 car (2/40).
 Co Trains: 1 car (light); 1 truck (light); 1 truck (medium); 2 trucks (3-ton).

KStN 192

1.02.1941

Light Anti-Aircraft Company (self-propelled)

Co Hqs: 4 mcl; 1 car (1); 1 car (15).
 Signal Det: Hqs Sect: 1 car (15).
 1 Lt Tele Sect *c*: 1 car (15).
 4 Pack Radio Sect *b*: 1 car (2).
 3 Lt AA Plt: Hqs Sect: 4 mcl; 1 car (15).
 Ammo Sect: 2 halftracks (10/4 without guns).
 Gun Sect: 4 halftracks (10/4 with 20mm Flak 38).
 Co Maint Sect: 1 mcl w/sc; 1 car (2/40).
 Co Trains: 3 mcl; 1 mcl w/sc; 2 trucks (light); 2 trucks (2-ton); 2 trucks (3-ton).

KStN 1225 *)

1.03.1942

Motorized Light Transport Column (30 tons)

Col Hqs: 1 mcl; 1 mcl w/sc; 1 car (light).
 2 Sect: 5 trucks (medium).
 Col Trains: 1 mcl w/sc; 2 trucks (light).

KStN 2251

1.02.1941

Motorized Field Post Detachment

Det: 1 car (medium); 1 bus (medium/33 seats); 2 vans (medium).

NOTES:

This organization applied for the SS-Sturmbrigade Reichsführer-SS.

Formation	Activated	Commanded by	Redesignated on 23.10.1943 as
Reichsführer-SS	01.06.1943	SS-Obersturmbannführer Karl Gesele	16. SS-Panzergrenadier-Division Reichsführer-SS

SS-STURMBRIGADE
SS Assault Brigade

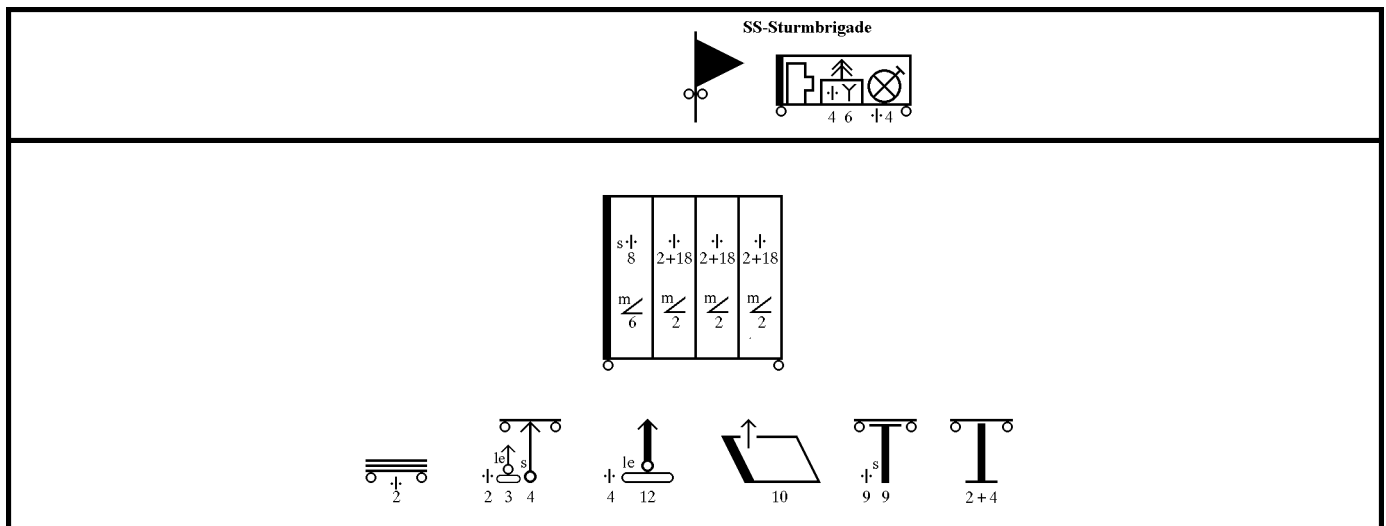

KStN 115c
1.11.1941
(modified)

Headquarters, Infantry Battalion (motorized)

Bn Hqs: 4 mcl; 2 mcl w/sc; 1 car (1); 2 cars (15).
Bn Hqs Trains: 1 mcl w/sc; 1 car (light); 1 truck (light); 2 trucks (medium); 1 ambulance (31).
Bn Maint Det: 1 mcl w/sc; 1 car (2/40); 1 car (light); 1 truck (light); 2 trucks (3-ton).
Bn Trains: 1 mcl; 2 cars (light); 2 trucks (medium); 6 trucks (3-ton).

KStN 129
1.11.1941
(modified)

Headquarters Company, Infantry Regiment (motorized)

Co Hqs: 2 mcl; 2 mcl w/sc; 1 car (12)
Motorcycle Plt: Hqs Sect: 1 mcl; 2 cars (15).
3 Recon Sqd: 1 mcl; 4 mcl w/sc; 1 Reconnaissance Squad with 1 LMG.
1 Messenger Sect: 8 mcl.
Engr Plt: Hqs Sect: 1 mcl; 1 mcl w/sc; 1 car (15).
3 Engr Sect: 1 mcl; 2 trucks (2-ton); 1 Engineer Section with 1 LMG.
Signal Plt: Hqs Sect: 1 mcl; 1 mcl w/sc; 3 cars (15).
2 Lt Tele Sect *d*: 1 car (15).
4 Pack Radio Sect *d*: ride in Headquarters Section vehicles.
4 Lt Radio Sect *e*: 1 van (17).
Maint Sect: 1 mcl w/sc; 1 car (2/40).
Co Trains: 1 mcl; 3 cars (light); 4 trucks (light); 2 trucks (medium).

KStN 1114
1.11.1941
(modified)

Motorized Infantry Company

Co Hqs: 3 mcl; 2 mcl w/sc; 1 car (15).
3 Inf Plt: Hqs Sect: 1 mcl; 1 car (15).
3 Inf Sqd: 2 trucks (70); 1 Infantry Squad w/ 2 LMG.
1 Hvy Plt: Hqs Sect: 1 mcl; 1 mcl w/sc; 1 car (15).
2 HMG Sect: 2 trucks (70); 2 HMG.
1 Mortar Sect: 3 trucks (70); 2 mortars (81mm).
Maint Sect: 1 mcl w/sc; 1 car (2/40).
Co Trains: 1 car (15); 1 truck (2-ton); 1 truck (medium); 1 truck (3-ton).

KStN 162
1.02.1941
(modified)

Machine Gun Company *Grossdeutschland* (motorized) [1]

Co Hqs: 4 mcl; 3 cars (15).
2 HMG Plt: Hqs Sect: 1 mcl w/sc; 2 car (15).
Gun Sect: 2 trucks (medium); 4 HMG.
1 Mortar Plt: Hqs Sect: 1 mcl; 2 cars (11).
Mortar Sect: 3 cars (11); 6 trucks (medium); 6 mortars (81mm).
Co Maint Sect: 1 mcl w/sc; 1 car (2/40).
Co Trains: 1 car (light); 3 trucks (light); 1 truck (medium).

KStN 174
1.12.1942
(modified)

Infantry Gun Company *Grossdeutschland* (motorized) [1]

Co Hqs: 5 mcl; 2 mcl w/sc; 2 cars (15).
Signal Det: 2 Lt Tele Sect *d*: 1 car (15).
2 Pack Radio Sect *d*: 1 car (2).
2 Lt IG Plt: Hqs Sect: 1 mcl; 1 mcl w/sc; 1 car (12).
Gun Sect: 6 cars (12); 4 trailers (ammo - *Sd.Ah.* 32); 2 light infantry guns (75mm - towed).
1 Hvy IG Plt: Hqs Sect: 1 mcl; 1 mcl w/sc; 1 car (12).
1 Lt Tele Sect *d*: 1 car (15).
Gu Sect: 4 halftracks (10); 2 trailers (ammo - *Sd.Ah.* 32); 2 heavy infantry guns (150mm - towed).
Co Maint Sect: 1 mcl w/sc; 1 car (2/40).
Co Trains: 1 car (light); 1 truck (light); 1 truck (medium); 2 trucks (3-ton).

KStN 1140
1.04.1943

Motorized Antitank Company [2]

Co Hqs: 3 mcl; 1 mcl w/sc; 1 car (15).
3 AT Plt: Hqs Sect: 1 mcl; 1 mcl w/sc; 1 car (1).
Gun Sect: 5 halftracks (11); 3 heavy antitank guns (75mm or 76.2mm - towed); 3 LMG.
Co Maint Sect: 1 mcl w/sc; 1 car (2/40).
Co Trains: 1 car (light); 1 truck (light); 1 truck (medium); 4 trucks (1½-ton).

SS-STURMBRIGADE
SS Assault Brigade

- KStN 446a**
1.11.1942 **Independent Assault Gun Battery (10 Guns)**
Bty Hqs: 3 mcl; 1 mcl w/sc; 1 car (15); 1 Sturmgeschütz III (142/1).
2 Lt Radio Sect *b*: 1 van (17).
3 AG Plt: Hqs Sect: 2 mcl w/sc.
 Ammo Sect: 2 trucks (3-ton); 1 trailer (ammo).
 Gun Sect: 3 Sturmgeschütz III (142/1) or 3 Sturmhaubitze III (142/2).
Maint Sect: 2 mcl w/sc; 4 trucks (3-ton); 1 halftrack (9); 1 trailer (22-ton/medium tank - *Sd.Ah. 116*).
Bty Trains: 1 mcl; 1 car (1); 1 AA car (4 w/ dual MG); 11 trucks (3-ton); 2 trailers (3-ton, equipment/ ammo).
- KStN 192**
1.02.1941 **Self-Propelled Antiaircraft Company [3]**
Co Hqs: 4 mcl; 1 car (1); 1 car (15); 1 LMG.
Signal Det: Hqs Sect: 1 car (15).
 1 Lt Tele Sect *c*: 1 car (15).
 4 Pack Radio Sect *b*: 1 car (2).
3 AA Plt: Hqs Sect: 3 mcl; 2 cars (15); 1 LMG.
 Gun Sect: Gun Sect: 4 halftracks (10/4 with 20mm Flak); 2 halftracks (10/4 without guns); 4 trailers (antiaircraft- *Sd.Ah. 51*).
Co Maint Sect: 1 mcl w/sc; 1 car (2/40); 1 truck (medium).
Co Trains: 3 mcl; 1 mcl w/sc; 1 car (15); 2 trucks (light); 2 trucks (2-ton); 2 trucks (3-ton).
- KStN 1711**
1.03.1942 **Motorized Heavy 88mm Army Antiaircraft Battery**
Bty Hqs: 3 mcl; 2 cars (15).
Calibration Det: Hqs Sect: 1 car (15).
 1 Calibration Sect I: 1 van (74); 1 trailer (gun director - *Sd.Ah. 104 or Sd.Ah. 52*).
 1 Calibration Sect II: 1 van (74); 1 trailer (auxiliary gun director - *Sd.Ah. 53*).
Signal Det: 1 Hvy Tele Sect *a*: 1 car (2); 1 van (23).
 1 Lt Radio Sect *b*: 1 van (17).
Lt AA Plt: 1 mcl w/sc; 3 trucks (81); 3 AA guns (20mm – towed - *Sd.Ah. 51*).
Hvy AA Plt: Hqs Sect: 1 mcl; 1 car (15); 1 halftrack (7); 1 trailer (w/o gun - *Sd.Ah.201/202*).
 Gun Sect: 4 halftracks (7); 4 AA guns (88mm – towed - *Sd.Ah.201/202*).
Ammo Det: 4 trucks (3-ton).
Maint Sect: 1 mcl w/sc; 1 car (2/40).
Bty Trains: 1 car (light); 2 trucks (light); 1 truck (medium); 1 truck (3-ton); 1 trailer (ammo).
- KStN 1231 *)**
1.03.1942 **Motorized Transport Column (60 tons)**
Col Hqs: 1 mcl; 1 mcl w/sc; 1 car (light).
2 Sect: 5 trucks (medium); 1 LMG.
2 Sect: 5 trucks (medium).
Col. Trains: 1 mcl w/sc; 2 trucks (light).

NOTES:

At this time the two SS-Sturm Brigade were reinforced infantry battalions.

- [1] The two *Grossdeutschland* organizations (KStN 162 and 174) were normally reserved for the Army's elite *Grossdeutschland-Division*, but the *Waffen-SS* could obviously choose and pick any organization they desired.
- [2] The motorized antitank company (KStN 1140) allowed three different prime movers, the 3-ton halftrack (*Sd.Kfz. 11*), the 3-ton Maultier (*Sd.Kfz. 3*), or a 3-ton all-wheel drive truck. The antitank guns could be the 7,5cm Pak 40, the 7,5cm Pak 97/38, or the 7,52cm Pak 36.
- [3] The self-propelled antiaircraft company (KStN 192) allowed two different motor mounts for the 20mm antiaircraft gun: the antiaircraft truck (*Sd.Kfz. 81*), or the 1-ton halftrack (*Sd.Kfz. 10/4*).

Formation	Activated	Commanded by	Redesignated on 23.10.1943 as
SS-Wallonien	01.06.1943	SS-Standartenführer Léon Degrelle	5. SS-Freiwilligen-Sturmbrigade Wallonien
SS-Langemark	31.05.1943	SS-Obersturmbannführer Conrad Schellong	6. SS-Freiwilligen-Sturmbrigade Langemark

SS-ARTILLERIE-REGIMENT (motorisiert)
Motorized SS Artillery Regiment

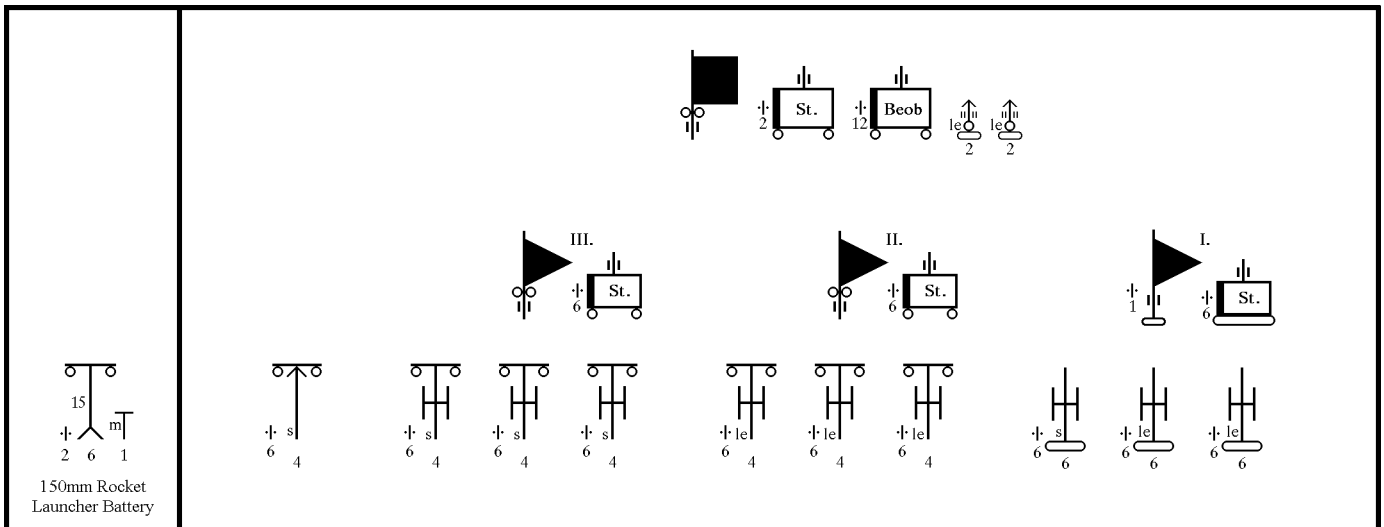
**KStN 410**

1.11.1941

Headquarters, Motorized Artillery Regiment

Rgt Hqs: 4 mcl; 1 car (1); 4 cars (15); 1 bus (medium).

KStN 578

1.11.1941

Headquarters Battery, Motorized Artillery Regiment

Bty Hqs: 2 mcl; 1 car (15).

Signal Plt: Hqs Sect: 1 mcl w/sc.

1 Hvy Tele Sect a: 1 car (2); 1 van (23).

1 Med tele Sect b: 1 car (15); 1 van (76).

3 Lt Tele Sect c: 1 car (15).

2 Lt Radio Sect b: 1 van (17).

4 Pack Radio Sect b: 1 car (2).

1 Lt Radio Sect c: 1 van (17/1).

Weather Sect: 1 mcl; 1 car (1); 1 van (76).

Printing Sect: 1 mcl; 1 car (light); 1 truck (medium); 1 van (62); 1 trailer (generator).

Maint Sect: 1 mcl w/sc; 1 car (2/40).

Bty Trains: 3 cars (light); 2 cars (medium); 1 car (4 w/dual MG); 1 truck (light); 5 trucks (medium); 1 bus (medium/33 seats).

ex-KStN 192(gek)

1.06.1943

2 Quad SP'd Plt: Hqs Sect: 1 mcl; 2 cars (15); 1 LMG.

Ammo Sect: 2 halftracks (7/1 w/o guns).

Gun Sect: 2 halftracks (7/1 with 20mm Quad Flak).

KStN 545

1.11.1941

Armored Artillery Observation Battery

Bty Hqs: 3 mcl; 2 cars (3); 1 SPW (251/12).

Flash Ranging Det: 6 SPW (251/12).

Advance Warning Sect: 2 SPW (251/12).

Sound Ranging Det: 4 cars (3); 4 SPW (251/12).

Evaluation Det: 2 cars (3); 4 vans (62); 1 van (63).

Printing Sect: 1 truck (medium); 1 van (62); 1 trailer (generator).

Weather Sect: 1 mcl; 1 van (62).

Maint Sect: 1 mcl w/sc; 1 car (2/40).

Bty Trains: 1 mcl; 1 car (light); 1 car (4 w/ dual MG); 5 trucks (medium); 1 van (42); 1 bus (light/15 seats); 1 trailer (generator).

KStN 547

1.02.1941

Calibration Platoon: Hqs Sect: 2 mcl; 1 car (16).

2 Calibration Sect: 2 cars (16).

1 Evaluation Sect: 1 van (62).

KStN 617

1.11.1941

Motorized Rocket Launcher Battery (150mm)

Bty Hqs: Hqs Sect: 2 car (1); 1 AA car (4 w/ dual MG).

Signal Det: Hqs Sect: 1 car (15).

2 Lt Tele Sect c: 1 car (15).

2 Pack Radio Sect f: 1 car (2).

1 Rocket Plt: Hqs Sect: 1 car (1).

Launcher Sect: 3 halftracks (11/4); 3 launchers (150mm – towed).

1 Rocket Plt: Hqs Sect: 1 halftrack (11/4); 1 ATG (37mm – towed).

Launcher Sect: 3 halftracks (11/4); 3 launchers (150mm – towed).

2 Ammo Det: 1 mcl w/sc; 3 halftracks (11/4); 3 trailers (ammo).

Maint Sect: 1 mcl w/sc; 1 car (2/40).

Bty Trains: 1 car (light); 4 trucks (light); 1 truck (medium).

Formation	Observation Battery	Anti-Aircraft (Platoons)	I. Battalion (1st – 3rd Batteries)	II. Battalion (4th – 6th Batteries)	III. Battalion (7th – 9th Batteries)	IV. Battalion (10th – 12th Batteries)
LSSAH	–	2x 20mm Quad Flak	3x 105mm FH (mot)	2x 105mm FH (SP'd) 1x 150mm FH (SP'd)	3x 150mm FH (mot)	1x 105mm Gun (mot) 2x 150mm Rocket Launcher (mot)
SS-DR	Yes	2x 20mm Quad Flak	3x 105mm FH (mot)	3x 105mm FH (mot)	2x 105mm FH (SP'd) 1x 150mm FH (SP'd)	2x 150mm FH (mot) 1x 105mm Gun (mot)
SS-T	Yes	2x 20mm Quad Flak	2x 105mm FH (SP'd) 1x 150mm FH (SP'd)	3x 105mm FH (mot)	3x 105mm FH (mot)	2x 150mm FH (mot) 1x 105mm Gun (mot)
SS-W	–	–	3x 105mm FH (mot)	3x 105mm FH (mot)	3x 105mm FH (mot)	2x 150mm FH (mot) 1x 105mm Gun (mot)
1. SS Brig (51. Bn)	–	–	2x 105mm FH (mot) 1x 150mm FH (mot)	–	–	–

NOTES:

LSSAH did not have a IV. Battalion. The three batteries were directly subordinate to the regimental headquarters. See page 47 for 'on Hand' self-propelled gun figures.

SS-ARTILLERIE-REGIMENT (motorisiert)
Motorized SS Artillery Regiment

- KStN 406**
1.11.1941
Headquarters, Motorized Artillery Battalion
Bn Hqs: 3 mcl; 1 mcl w/sc; 1 car (1); 4 cars (15); 1 truck (medium).
- KStN 586**
1.11.1941
Headquarters Battery, Motorized Artillery Battalion
Bty Hqs: 2 mcl; 1 car (15).
Signal Plt: Hqs Sect: 1 mcl w/sc.
1 Med Tele Sect *b*: 1 car (15); 1 van (76).
3 Lt Tele Sect *c*: 1 car (15).
4 Pack Radio Sect *b*: 1 car (2).
1 Lt Radio Sect *c*: 1 van (17/1).
Calibration Sect: 1 mcl; 1 car (3); 1 truck (2-ton).
Bty Maint Sect: 1 mcl w/sc; 1 car (2/40).
Bn Main Det: 1 car (light); 3 trucks (medium).
Bn Trains: 4 mcl; 4 cars (light); 1 car (4 w/ dual MG); 4 trucks (light); 21 trucks (medium); 1 ambulance (31).
- KStN 434**
1.11.1941
Motorized 105mm Light Field Howitzer Battery
Bty Hqs: 3 mcl; 3 cars (15).
Signal Det: Hqs Sect: 1 car (15).
1 Med Tele Sect *b*: 1 car (15); 1 van (76).
1 Lt Tele Sect *c*: 1 car (15).
1 Pack Radio Sect *b*: 1 car (2).
Gun Plt: Hqs Sect: 1 mcl; 1 car (1); 1 car (4 w/ dual MG); 1 car (15); 1 halftrack (11).
Ammo Det: 1 car (light); 4 trucks (3-ton).
2 Gun Sect: 2 halftracks (11); 2 lt Field Howitzers (105mm – towed).
Maint Sect: 1 mcl w/sc; 1 car (2/40).
Bty Trains: 1 truck (light); 3 trucks (medium).
- KStN 462 *)**
1.11.1941
Motorized 150mm Field-Howitzer Battery
Bty Hqs: 3 mcl; 3 cars (15).
Signal Det: Hqs Sect: 1 car (15).
1 Med Tele Sect *b*: 1 car (15); 1 van (76).
1 Lt Tele Sect *c*: 1 car (15).
1 Pack Radio Sect *f*: 1 car (2).
1 Lt Radio Sect *c*: 1 van (17/1).
Gun Plt: Hqs Sect: 1 mcl; 1 car (1); 1 AA car (4 w/ dual MG); 1 car (15); 1 halftrack (7).
Ammo Sect: 1 car (light); 4 trucks (3-ton).
2 Gun Sect: 2 halftracks (7); 2 hvy Field Howitzers (150mm – towed).
Maint Sect: 1 mcl w/sc; 1 car (2/40).
Bty Trains: 4 trucks (medium).
- KStN 454**
1.11.1941
Motorized 105mm Gun Battery
Bty Hqs: 3 mcl; 3 cars (15).
Signal Det: Hqs Sect: 1 car (15).
1 Med Tele Sect *b*: 1 car (15); 1 van (76).
1 Lt Tele Sect *c*: 1 car (15).
1 Pack Radio Sect *f*: 1 car (2).
1 Lt Radio Sect *c*: 1 van (17/1).
Gun Plt: Hqs Sect: 1 mcl; 1 car (1); 1 AA car (4 w/ dual MG); 1 car (15); 1 halftrack (7).
Ammo Sect: 1 car (light); 4 trucks (3-ton).
2 Gun Sect: 2 halftracks (7); 2 Guns (105mm – towed).
Maint Sect: 1 mcl w/sc; 1 car (2/40).
Bty Trains: 4 trucks (medium).
- KStN 407**
16.01.1943
Headquarters, Self-Propelled Artillery Battalion
Bn Hqs: 3 mcl; 1 mcl w/sc; 1 car (1); 3 cars (15); 2 Artillery Observation Tanks (143).
- KStN 583**
16.01.1943
Headquarters Battery, Self-Propelled Artillery Battalion
Bty Hqs: 1 mcl; 1 car (15).
Signal Plt: Hqs Sect: 1 car (15); 1 van (17).
1 Armd Air-Liaison Radio Sect: 1 AC (260).
1 Hvy Tele Sect *a*: 1 car (2); 1 van (23).
2 Lt Tele Sect: 1 car (15).
Artillery Calibration Sect: 1 mcl; 1 car (3); 1 truck (3-ton).
Bty Maint Sect: 1 mcl w/sc; 1 car (2/40).
Bty Trains: 2 cars (1); 1 AA car (4 w/ dual MG); 1 car (15); 5 trucks (medium); 2 trucks (3-ton); 1 ambulance (31); 2 LMG.
Bn Maint Det: 1 mcl; 1 mcl w/sc; 1 car (light); 6 trucks (3-ton); 1 halftrack (9); 1 halftrack crane (9/1 – 6-ton);
2 trailers (tank – 22-ton).
Bn Admin Det: 1 mcl; 3 car (light); 13 trucks (medium).
- KStN 431b**
16.01.1943
Self-Propelled Light Field Howitzer Battery
Bty Hqs: 1 mcl; 1 mcl w/sc; 1 VW (1); 2 Artillery Observation Tanks (143).
Signal Det: Hqs Sect: 1 car (2).
Med Tele Sect *b*: 1 car (15); 1 van (76).
Lt Tele Sect: 1 car (15).
Gun Plt: Hqs Sect: 1 mcl w/sc; 1 VW (1); 3 cars (15).
Gun Sect: 6 Wespe SP'd lt Field Howitzers (124); 2 LMG.
Ammo Det: 1 mcl w/sc; 4 trucks (3-ton); 2 Wespe ammunition carriers (w/o howitzers).
Bty Maint Plt: 2 mcl w/sc; 1 VW (2/40); 3 trucks (3-ton).
Bty Trains: 4 trucks (medium); 2 trucks (3-ton); 1 van (3-ton).
- KStN 461b**
16.01.1943
Self-Propelled Heavy Field Howitzer Battery
Bty Hqs: 1 mcl; 1 mcl w/sc; 1 VW (1); 2 Artillery Observation Tanks (143).
Signal Det: Hqs Sect: 1 car (2).
Med Tele Sect *b*: 1 car (15); 1 van (76).
Lt Tele Sect: 1 car (15).
Gun Plt: Hqs Sect: 1 mcl w/sc; 1 VW (1); 3 cars (15).
Gun Sect: 6 Hummel SP'd hvy Field Howitzers (165); 2 LMG.
Ammo Det: 1 mcl w/sc; 4 trucks (3-ton); 3 Hummel ammunition carriers (w/o howitzers).
Bty Maint Plt: 2 mcl w/sc; 1 VW (2/40); 3 trucks (3-ton).
Bty Trains: 4 trucks (medium); 2 trucks (3-ton); 1 van (3-ton).

SS FLAK-ABTEILUNG (motorisiert)
Motorized SS Antiaircraft Battalion

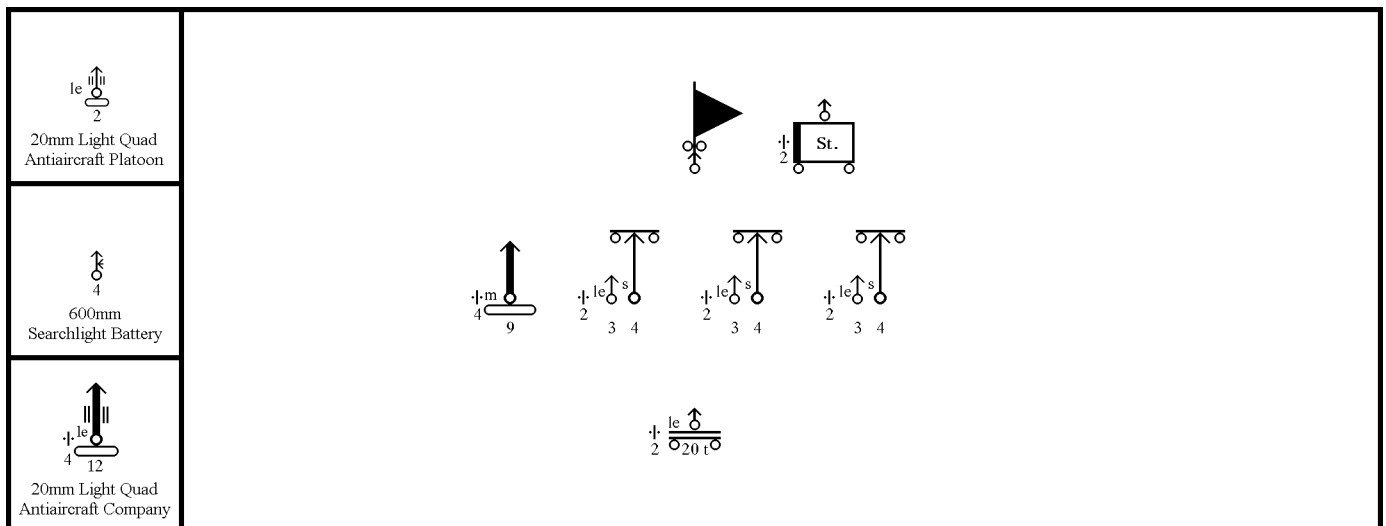

KStN 1705
1.11.1941

Headquarters, Motorized Army Anti-Aircraft Battalion
Bn Hqs: 3 mcl; 1 car (light); 3 cars (15).

KStN 1709
1.04.1943

Headquarters Battery, Motorized Army Anti-Aircraft Battalion

Bty Hqs: 1 car (15).
 Signal Plt: Hqs Sect: 1 mcl; 1 mcl w/sc; 1 car (15); 1 LMG.
 1 Hvy Tele Sect *a*: 1 car (2); 1 van (23).
 3 Lt Tele Sect *c*: 1 car (15).
 1 Pack Radio Sect *b*: 1 car (2).
 1 Lt Radio Sect *a*: 1 van (17).
 1 Med Radio Sect *b*: 1 car (15); 1 van (17).
 Weather Sect: 1 mcl; 1 van (61).
 Evaluation Sect: 1 truck (medium).
 Bty Maint Sect: 1 mcl w/sc; 1 car (2/40).
 Bn Maint Det: 1 car (light); 1 truck (medium); 3 trucks (3-ton).
 Bn Trains: 2 cars (light); 1 car (1); 3 trucks (light); 6 trucks (medium); 1 ambulance (31).

KStN 511
1.03.1943

Motorized Light Artillery Column

Col: 2 mcl; 1 mcl w/sc; 2 trucks (light); 12 trucks (medium).

KStN 1711
1.03.1942

Motorized Army Anti-Aircraft Battery (88mm)

Bty Hqs: 3 mcl; 2 cars (15).
 Calibration Det: Hqs Sect: 1 car (15).
 2 Calibration Sect: 1 van (74); 1 trailer (gun director).
 Signal Det: 1 Hvy Tele Sect *a*: 1 car (2); 1 van (23).
 1 Lt Radio Sect *b*: 1 van (17).
 Ammo Det: 4 trucks (3-ton).
 Lt AA Plt: 1 mcl w/sc; 3 trucks (81); 3 AA guns (20mm – towed).
 Hvy AA Plt: Hqs Sect: 1 mcl; 1 car (15); 1 halftrack (7); 1 trailer (w/o gun).
 Gun Sect: 4 halftracks (7); 4 AA guns (88mm – towed).
 Maint Sect: 1 mcl w/sc; 1 car (2/40).
 Bty Trains: 1 car (light); 2 trucks (light); 1 truck (81); 3 trucks (medium); 1 trailer (ammo).

KStN 198
1.02.1941

Self-Propelled Medium Anti-Aircraft Company (37mm)

Co Hqs: 2 mcl; 2 mcl w/sc; 1 car (medium); 1 car (12); 1 LMG.
 Signal Det: Hqs Sect: 1 car (2).
 1 Lt Tele Sect *c*: 1 car (15).
 1 Lt Radio Sect *b*: 1 van (17).
 4 Pack Radio Sect *b*: 1 car (2).
 Ammo Det: 1 mcl; 3 trucks (3-ton).
 3 Gun Plt: Hqs Sect: 3 mcl; 1 car (15).
 Gun Sect: 3 halftracks (6/2 with 37mm Flak); 1 truck (3-ton); 1 LMG.
 Maint Sect: 1 mcl w/sc; 1 car (2/40); 1 truck (medium).
 Co Trains: 5 mcl; 1 mcl w/sc; 1 car (15); 4 trucks (1.5-ton); 3 trucks (3-ton).

KStN 192(gek)
1.06.1943

Mechanized Light Anti-Aircraft Company (20mm)

Co Hqs: 2 mcl; 1 car (15); 1 LMG.
 Signal Det: Hqs Sect: 1 car (15).
 1 Lt Tele Sect *c*: 1 car (15).
 3 Pack Radio Sect *b*: 1 car (2).
 3 Gun Plt: Hqs Sect: 3 mcl; 2 cars (15); 1 LMG.
 Ammo Sect: 2 trucks (81).
 Gun Sect: 4 trucks (81); 4 AA Guns (20mm Flak 30 – towed); 4 trailers (Sd.Ah. 51).
 Maint Sect: 1 car (2/40); 1 truck (medium).
 Co Trains: 1 mcl w/sc; 1 car (15); 4 trucks (1.5-ton); 2 trucks (3-ton).
 Maint Sect: 1 mcl w/sc; 1 car (2/40); 1 truck (medium).
 Co Trains: 2 mcl; 1 mcl w/sc; 1 car (15); 2 trucks (light); 2 trucks (2-ton); 2 trucks (3-ton).

**SS FLAK-ABTEILUNG (motorisiert)
Motorized SS Anti-Aircraft Battalion**

KStN 192a *)	Mechanized Light Quad Anti-Aircraft Company (20mm)
29.09.1942	Co Hqs: 4 mcl; 2 cars (15); 1 LMG. Signal Det: Hqs Sect: 4 mcl; 1 car (15). 1 Lt Tele Sect c: 1 car (15). 3 Pack Radio Sect b: 1 car (2). 3 Gun Plt: Hqs Sect: 3 mcl; 1 car (15); 1 LMG. Ammo Sect: 2 halftracks (7/1 without guns). Gun Sect: 2 halftracks (7/1 with 20mm quad Flak); 2 trailers (<i>Sd.Ah. 52</i>). Maint Sect: 1 car (2/40); 1 truck (medium). Co Trains: 1 mcl w/sc; 1 car (15); 4 trucks (1.5-ton); 2 trucks (3-ton). Maint Sect: 1 mcl w/sc; 1 car (2/40); 1 truck (medium). Co Trains: 2 mcl; 1 mcl w/sc; 1 car (15); 2 trucks (light); 2 trucks (2-ton); 2 trucks (3-ton).
KStN 194	Self-Propelled Light Quad Anti-Aircraft Platoon (20mm)
1.02.1941	Plt: 5 mcl; 1 car (15); 2 trucks (81 w/ 20mm quad Flak); 2 trucks (81 w/o guns for ammo); 2 trailers (<i>Sd.Ah. 52</i>); 1 LMG.
KStN 1714	Motorized Searchlight Detachment (600mm)
1.12.1942	Det: 4 trucks (3-ton); 4 searchlights (600mm - <i>Sd.Ah. 51</i>).

NOTES:

Even though the light 20mm guns were self-propelled, the units also had the special trailers (*Sd.Ah. 51* and *Sd.Ah. 52*) for towing these weapons. Although listed in the Gun Platoons, they were towed by trains vehicles until needed.

Formation	1st Battery	2nd Battery	3rd Battery	4th Battery	5th Battery	6th Battery
LSSAH	Heavy (mot)	Heavy (mot)	Heavy (mot)	Medium (SP'd) #	Medium (SP'd) #	Light Quad (SP'd) #
SS-DR	Heavy (mot)	Heavy (mot)	Heavy (mot)	Medium (SP'd) + Quad Plt	–	
SS-T	Heavy (mot)	Heavy (mot)	Heavy (mot)	Medium (SP'd)	–	
SS-W	Heavy (mot)	Heavy (mot)	Light (SP'd) + Medium Plt	–		
RFSS Brig	Heavy (mot)	Heavy (mot)	Medium (SP'd)	–	–	
1. mot Brig	Medium (SP'd)	–	–	–	–	

With Searchlight Detachment.

SS-PANZERJÄGER-ABTEILUNG
Mechanized SS Antitank Battalion

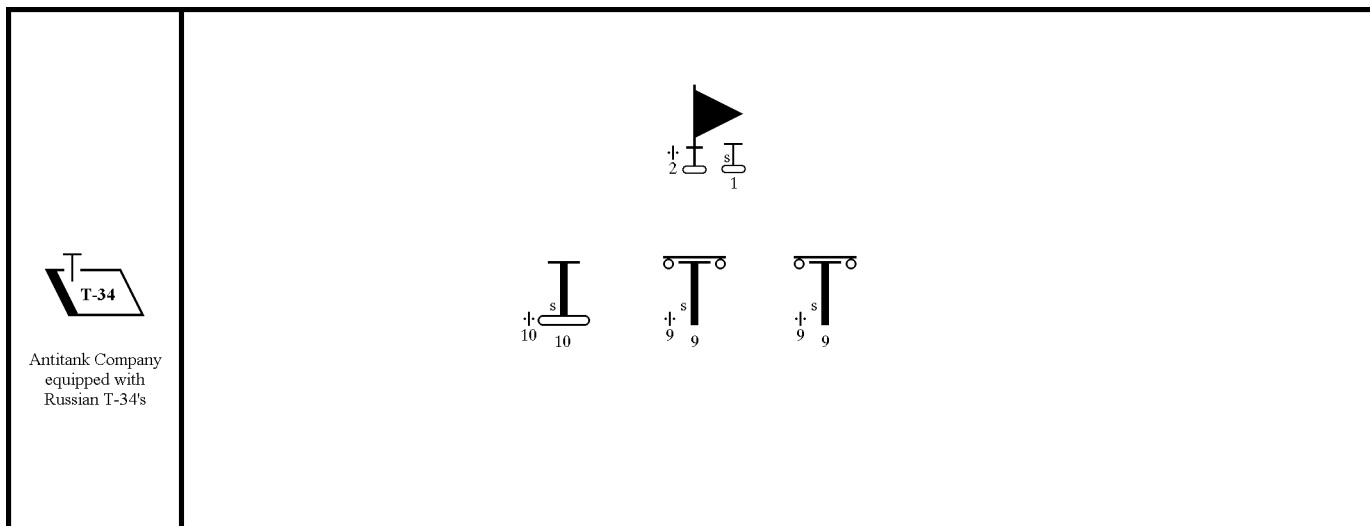
**KStN 1106**

1.11.1941

Headquarters, Motorized Anti-Tank Battalion

Bn Hqs: 2 mcl; 1 mcl w/sc; 1 car (12); 1 car (15); 1 car (21).

Signal Det: 1 Lt Tele Sect *c*: 2 mcl; 1 car (15).4 Pack Radio Sect *b*: 1 car (2).2 Lt Armd Radio Sect *d*: 1 AC (261).

Hqs Maint Sect: 1 mcl w/sc; 1 car (2/40).

Bn Maint Det: 1 car (medium); 1 truck (light); 2 trucks (3-ton).

Bn Trains: 1 mcl w/sc; 3 cars (light); 2 trucks (light); 1 truck (2-ton); 2 trucks (medium); 1 truck (3-ton); 1 ambulance (31).

KStN 1106a

1.11.1941

Headquarters, Self-Propelled Anti-Tank Battalion

Bn Hqs: 2 mcl; 1 mcl w/sc; 1 car (12); 1 car (15); 1 self-propelled antitank gun.

Signal Det: 1 Lt Tele Sect *c*: 2 mcl; 1 car (15).4 Pack Radio Sect *b*: 1 car (2).2 Lt Radio Sect *b*: 1 van (17).

Bn Maint Det: 1 mcl w/sc; 1 car (2/40); 1 car (medium); 2 trucks (light); 1 truck (2-ton); 3 trucks (3-ton); 1 van (79); 1 halftrack (7);

1 trailer (generator - *A*); 1 trailer (10-ton – *Sd.Ah. 115*).

Bn Trains: 1 mcl; 1 mcl w/sc; 2 cars (light); 2 trucks (light); 2 trucks (2-ton); 2 trucks (3-ton); 1 ambulance (31).

KStN 1140

1.04.1943

Motorized Heavy Antitank Company

Co Hqs: 3 mcl; 1 mcl w/sc; 1 car (15).

3 ATG Plt: Hqs Sect: 1 mcl; 1 mcl w/sc; 1 car (15).

Gun Sect: 5 halftracks (11); 3 ATG (76.2mm or 75mm – towed); 3 LMG.

Maint Det: 1 mcl w/sc; 1 car (2/40).

Co Trains: 1 car (1); 1 truck (light); 4 trucks (1.5-ton); 1 truck (medium).

KStN 1148d

1.06.1943

Self-Propelled Heavy Antitank Company

Co Hqs: 2 mcl; 1 VW (1); 1 car (15); 1 self-propelled antitank gun (76.2mm or 75mm).

3 ATG Plt: Hqs Sect: 1 mcl; 1 mcl w/sc; 1 car (1); 2 Maultier (3).

Gun Sect: 3 self-propelled antitank gun (76.2mm or 75mm); 4 LMG.

Maint Sect: 2 VW (1); 1 car (2/40); 2 trucks (3-ton); 1 halftrack (10); 1 halftrack (8).

Co Trains: 1 car (light); 1 VW (1); 1 truck (light); 1 truck (1.5-ton); 4 trucks (medium); 7 trucks (3-ton).

Formation	Headquarters	1st Company	2nd Company	3rd Company
LSSAH	SP'd (1x 75mm SP'd)	(SP'd) 10x 75mm Pak	(SP'd) 10x 75mm Pak	(SP'd) 10x 75mm Pak
SS-DR	mot	(SP'd) 2x 75mm & 8x 76.2mm Pak	(mot) 9x 75mm Pak	(mot) 9x 75mm Pak
SS-T	SP'd (1x 76.2mm SP'd)	(SP'd) 10x 76.2mm Pak	(mot) 9x 75mm Pak	(mot) 9x 75mm Pak
SS-W	mot	(mot) 9x 75mm or 76.2mm Pak	(mot) 9x 75mm or 76.2mm Pak	(SP'd) 10x 75mm Pak
RFSS Brig	–	(mot) 9x 75mm Pak	–	–
1. mot Brig	–	(mot) 12x 75mm or 76.2mm Pak	–	–

NOTES:

The headquarters of the self-propelled battalions were supposed to have a Pz-I (*Sd.Kfz. 101*) without turret as the command vehicle for the battalion commander. No strength report ever indicated this vehicle as being present. Instead there was usually a self-propelled antitank gun such as found in of of the battalion's companies.

The SS-DR had equipped one company with medium Russian T-34 tanks, probably using the self-propelled organization, but with tanks instead of antitank guns. By 4.07.1943 there were 18 operational T-34's, with 9 more in maintenance.

See page 47 for 'on Hand' figures.

LSSAH-PANZER-AUFKLÄRUNGS-ABTEILUNG
LSSAH Armored Reconnaissance Battalion

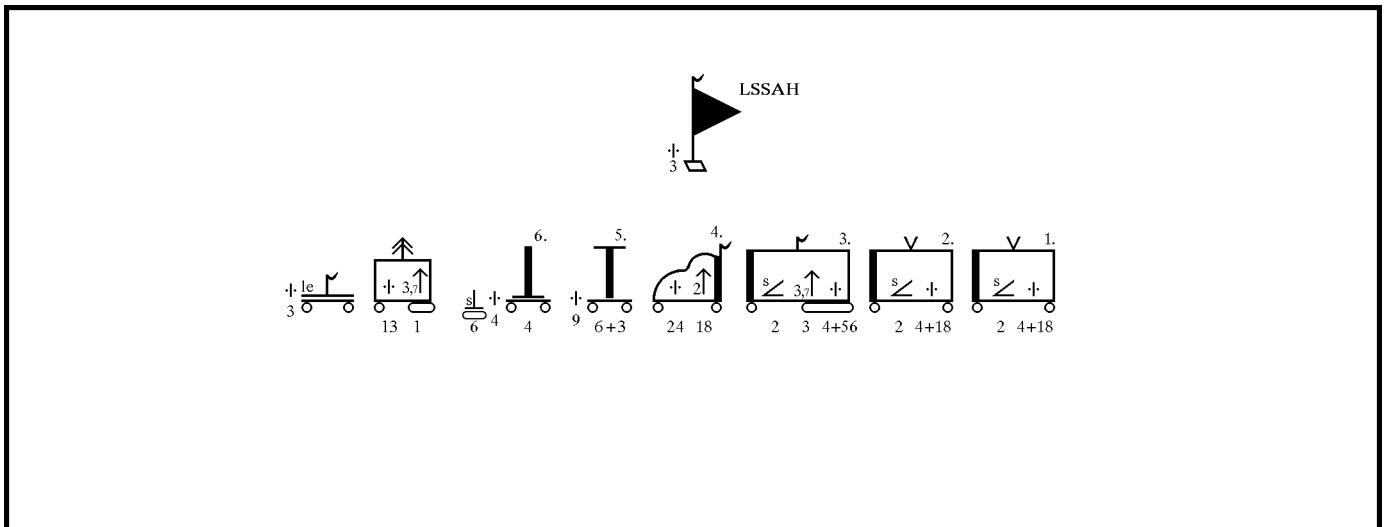

KStN 1109(gp) *) Headquarters, Armored Reconnaissance Battalion

16.01.1943
 Bn Hqs: 8 mcl; 2 mcl w/sc; 3 cars (15); 1 SPW (250/3).
 Signal Plt: Hqs Sect: 1 VW (1); 1 SPW (250/3).
 1 Lt Armd Tele Sect c: 1 SPW (251/11)
 1 Lt Armd Radio Sect b: 1 SPW (250/3).
 4 Lt Armd Radio Sect c: 1 AC (261).
 3 Med Armd Radio Sect b: 1 SPW (251/3).
 Maint Sect: 1 mcl w/sc; 1 car (2/40); 1 car (light); 3 trucks (3-ton); 1 halftrack (7).
 Bn Trains: 3 VW (1); 3 trucks (medium); 8 trucks (3-ton); 1 armored ambulance (251/8).

KStN 1113 Motorized Light Reconnaissance Company (Volkswagen)

18.03.1942
 Co Hqs: 4 mcl w/sc; 3 VW (1).
 3 Recon Plt: Hqs Sect: 1 mcl; 1 VW (1).
 3 Inf Sqd: 4 VW (1); 1 Reconnaissance Squad w/ 2 LMG.
 1 Hvy Plt: Hqs Sect: 1 mcl; 3 VW (1).
 2 HMG Sect: 7 VW; 2 HMG.
 1 Mortar Sect: 3 trucks (70); 2 mortars (18mm).
 Maint Sect: 1 VW (1); 1 VW (2/40).
 Co Trains: 1 VW (1); 1 truck (2-ton); 1 truck (medium); 1 truck (3-ton).

KStN 1113(gp) Armored Light Reconnaissance Company

1.03.1942
 Co Hqs: 4 mcl; 1 mcl w/sc; 2 SPW (250/3).
 3 Recon Plt: Hqs Sect: 1 SPW (250/1); 1 SPW (250/10 w/ 37mm ATG).
 3 Sqd: 2 SPW (250/1); 1 Reconnaissance Squad w/ 2 LMG.
 1 Hvy Plt: Hqs Sect: 1 mcl; 1 SPW (250/1).
 2 HMG Sect: 3 SPW (250/1); 2 HMG.
 1 Mortar Sect: 2 SPW (250/7 w/ 81mm mortars); 2 SPW (250/7 w/o mortars).
 Maint Sect: 1 mcl w/sc; 2 trucks (2-ton); 1 halftrack (10); 1 LMG.
 Co Trains: 1 car (15); 1 truck (2-ton); 1 truck (medium); 2 trucks (3-ton).

KStN 1162 Armored Car Company (Wheeled)

1.11.1941
 Co Hqs: 2 mcl; 5 mcl w/sc; 1 car (15).
 1 Hvy AC Plt: 3 AC (231); 3 AC (232).
 3 Lt AC Plt: 4 AC (222); 2 AC (223).
 Maint Sect: 1 mcl w/sc; 1 car (2/40); 2 trucks (2-ton).
 Co Trains: 1 car (15); 3 trucks (2-ton); 1 truck (medium); 1 truck (3-ton).

KStN 1140 Motorized Antitank Company

1.04.1943
 Co Hqs: 3 mcl; 1 mcl w/sc; 1 car (15).
 1 AT Plt: Hqs Sect: 1 mcl; 1 mcl w/sc; 1 car (12).
 Gun Sect: 5 trucks (69); 3 antitank guns (37mm – towed); 2 LMG.
 2 AT Plt: Hqs Sect: 1 mcl; 1 mcl w/sc; 1 car (1).
 Gun Sect: 5 halftracks (11); 3 heavy antitank guns (75mm or 76.2mm – towed); 3 LMG.
 Co Maint Sect: 1 mcl w/sc; 1 car (2/40).
 Co Trains: 1 car (light); 1 truck (light); 1 truck (medium); 4 trucks (1½-ton).

KStN 174 Infantry Gun Company (motorized) / Grossdeutschland

1.12.1942
 (modified)
 Co Hqs: 5 mcl; 2 mcl w/sc; 2 cars (15).
 Signal Det: 2 Lt Tele Sect d: 1 car (15).
 2 Pack Radio Sect d: 1 car (2).
 1 Lt IG Plt: Hqs Sect: 1 mcl; 1 mcl w/sc; 1 car (12).
 Gun Sect: 6 cars (12); 4 trailers (ammo – *Sd.Ah.* 32); 2 light infantry guns (75mm – towed).
 1 Hvy IG Plt: Hqs Sect: 1 mcl; 1 mcl w/sc; 1 car (15).
 1 Lt Tele Sect d: 1 car (15).
 Gun Sect: 2 halftracks (10); 2 light infantry guns (150mm – towed).

Improvised unit

3 Self-Propelled Infantry Gun Platoons:

Hqs Sect: 1 mcl; 1 mcl w/sc; 1 SPW (250/3).
 Gun Sect: 2 SP'd 150mm IG (138/1).
 Co Maint Sect: 1 mcl w/sc; 1 car (2/40).
 Co Trains: 1 car (light); 1 truck (light); 1 truck (medium); 2 trucks (3-ton).

KStN 1124a(gp) Armored Engineer Platoon

1.03.1943
 Hqs Sect: 1 mcl; 1 mcl w/sc; 1 SPW (251/10 with 37mm gun); 3 trucks (3-ton).
 3 Engr Sect: 1 SPW (251/7); 1 Engineer Section w/ 2 LMG.

KStN 1181 Motorized Light Reconnaissance Column

1.02.1941
 Col Hqs: 3 mcl; 4 mcl w/sc; 1 car (15); 3 LMG.
 1 Sect: 1 mcl; 5 trucks (2-ton).
 2 Sect: 4 trucks (medium).
 Col Trains: 1 mcl w/sc; 2 trucks (medium).

SS-PANZER-AUFKLÄRUNGS-ABTEILUNG
Armored SS Reconnaissance Battalion

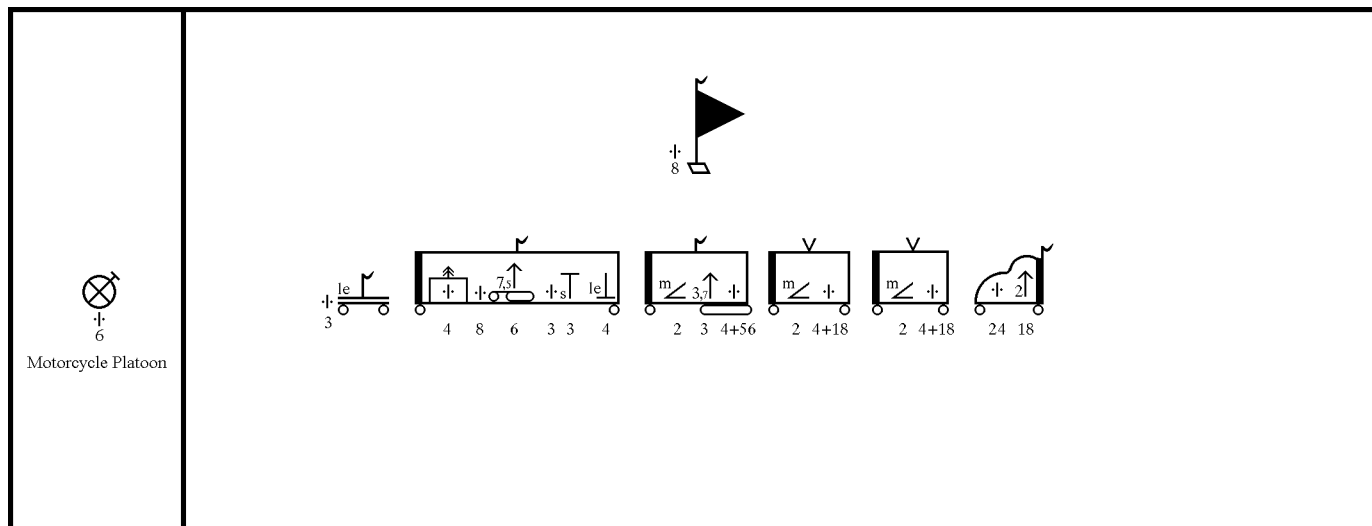

KStN 1109(gp) * Headquarters, Armored Reconnaissance Battalion

16.01.1943

Bn Hqs: 8 mcl; 2 mcl w/sc; 3 cars (15); 1 SPW (250/3).
 Signal Plt: Hqs Sect: 1 VW (1); 1 SPW (250/3).
 1 Lt Armd Tele Sect c: 1 SPW (251/11)
 1 Lt Armd Radio Sect b: 1 SPW (250/3).
 4 Lt Armd Radio Sect c: 1 AC (261).
 3 Med Armd Radio Sect b: 1 SPW (251/3).
 Maint Sect: 1 mcl w/sc; 1 car (2/40); 1 car (light); 3 trucks (3-ton); 1 halftrack (7).
 Bn Trains: 3 VW (1); 3 trucks (medium); 8 trucks (3-ton); 1 armored ambulance (251/8).

KStN 1162 Armored Car Company (Wheeled)

1.11.1941

Co Hqs: 2 mcl; 5 mcl w/sc; 1 car (15).
 1 Hvy AC Plt: 3 AC (231); 3 AC (232).
 3 Lt AC Plt: 4 AC (222); 2 AC (223).
 Maint Sect: 1 mcl w/sc; 1 car (2/40); 2 trucks (2-ton).
 Co Trains: 1 car (15); 3 trucks (2-ton); 1 truck (medium); 1 truck (3-ton).

ex KStN 1112

1.11.1941

Motorcycle Platoon

Hqs Sect: 1 mcl; 2 cars (15); 1 ATR.
 3 Mcl Sect: 4 mcl w/sc; 1 Infantry Squad with 2 LMG.

KStN 1113 Motorized Light Reconnaissance Company (Volkswagen)

18.03.1942

Co Hqs: 4 mcl w/sc; 3 VW (1).
 3 Recon Plt: Hqs Sect: 1 mcl; 1 VW (1).
 3 Inf Sqd: 4 VW (1); 1 Reconnaissance Squad w/ 2 LMG.
 1 Hvy Plt: Hqs Sect: 1 mcl; 3 VW (1).
 2 HMG Sect: 7 VW; 2 HMG.
 1 Mortar Sect: 3 trucks (70); 2 mortars (18mm).
 Maint Sect: 1 VW (1); 1 VW (2/40).
 Co Trains: 1 VW (1); 1 truck (2-ton); 1 truck (medium); 1 truck (3-ton).

KStN 1113(gp) Armored Light Reconnaissance Company

1.03.1942

Co Hqs: 4 mcl; 1 mcl w/sc; 2 SPW (250/3).
 3 Recon Plt: Hqs Sect: 1 SPW (250/1); 1 SPW (250/10 w/ 37mm ATG).
 3 Sqd: 2 SPW (250/1); 1 Reconnaissance Squad w/ 2 LMG.
 1 Hvy Plt: Hqs Sect: 1 mcl; 1 SPW (250/1).
 2 HMG Sect: 3 SPW (250/1); 2 HMG.
 1 Mortar Sect: 2 SPW (250/7 w/ 81mm mortars); 2 SPW (250/7 w/o mortars).
 Maint Sect: 1 mcl w/sc; 2 trucks (2-ton); 1 halftrack (10); 1 LMG.
 Co Trains: 1 car (15); 1 truck (2-ton); 1 truck (medium); 2 trucks (3-ton).

Motorized Heavy Company

KStN 1121

1.11.1941

Co Hqs: 3 mcl; 2 mcl w/sc; 1 car (15).
 Lt Tele Sect c: 1 car (15).
 Maint Sect: 1 mcl w/sc; 1 car (2/40).
 Co Trains: 1 car (15); 1 truck (2-ton); 2 trucks (medium); 1 truck (3-ton).

KStN 1122a

1.12.1941

ATG Plt: Hqs Sect: 1 mcl; 1 mcl w/sc; 1 car (15).
 Gun Sect: 5 halftracks (10); 3 ATG (50mm - towed); 2 trailers (ammo); 3 LMG.

KStN 1123

1.11.1941

IG Plt: Hqs Sect: 1 mcl; 1 mcl w/sc; 1 truck (69).
 Gun Sect: 3 trucks (69); 2 lt IG (75mm - towed); 1 trailer (ammo).

KStN 1124

1.11.1941

Engr Plt: Hqs Sect: 1 mcl; 1 mcl w/sc; 1 car (15); 2 trucks (2-ton).
 4 Engr Sect: 1 truck (2-ton); 1 Engineer Section w/ 1 LMG.

KStN 1125(gp)

1.05.1943

Gun Plt: Hqs Sect: 1 mcl w/sc; 1 SPW (251/3).
 Gun Sect: 6 SPW (251/9).
 Ammo Det: 1 SPW (251/4); 1 truck (3-ton).

KStN 1181 Motorized Light Reconnaissance Column

1.02.1941

Col Hqs: 3 mcl; 4 mcl w/sc; 1 car (15); 3 LMG.
 1 Sect: 1 mcl; 5 trucks (2-ton).
 2 Sect: 4 trucks (medium).
 Col Trains: 1 mcl w/sc; 2 trucks (medium).

NOTES:

This organization applied to the SS-DR and SS-T. The SS-DR had a motorcycle platoon assigned to the armored car company.

SS-AUFKLÄRUNGS-ABTEILUNG
Motorized SS Reconnaissance Battalion

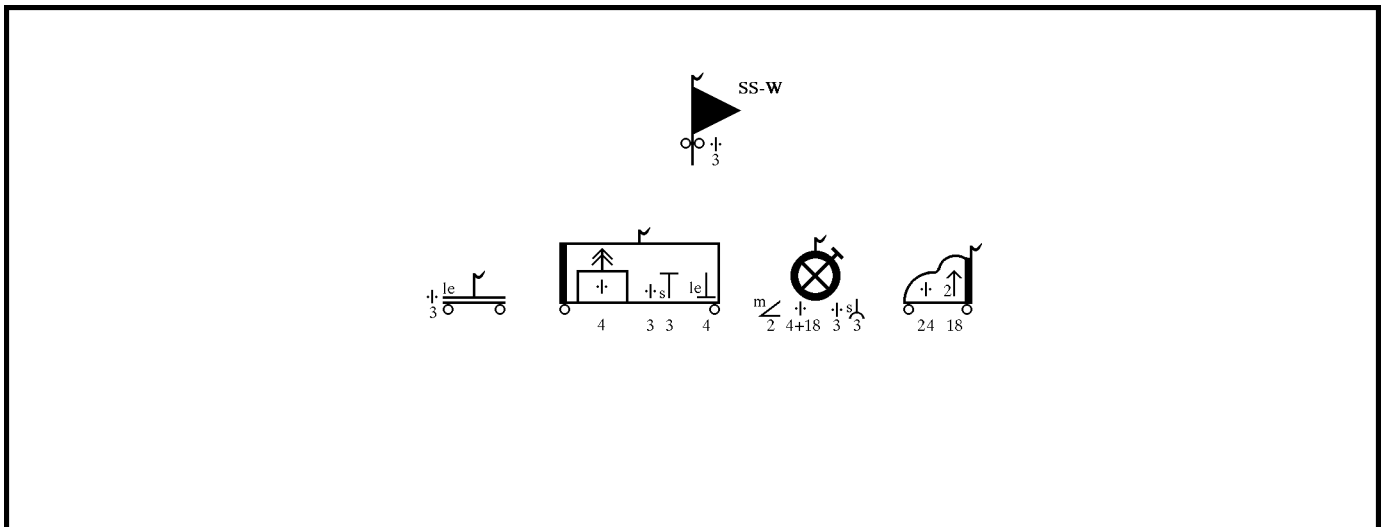
**KStN 1109**

1.11.1941

Headquarters, Motorcycle Infantry Battalion

Bn Hqs: 8 mcl; 2 mcl w/sc; 3 cars (15); 1 AC (247).
 Signal Det: Hqs Sect: 1 mcl; 1 mcl w/sc; 1 car (15).
 1 Lt Tele Sect *c*: 1 car (15).
 2 Pack Radio Sect *b*: 1 car (2).
 4 Lt Armd Radio Sect *d*: 1 AC (260).
 3 Med Armd Radio Sect *d*: 1 car (15); 1 AC (263).
 Bn Hqs Trains: 1 mcl w/sc; 1 car (light); 1 truck (2-ton); 2 trucks (3-ton); 1 ambulance (31).
 Bn Maint Det: 1 mcl; 1 mcl w/sc; 1 car (2/40); 1 car (15); 5 trucks (2-ton).
 Bn Trains: 1 mcl; 3 cars (light); 1 truck (2-ton); 5 trucks (medium); 6 trucks (3-ton).

KStN 1162

1.11.1941

Armored Car Company

Co Hqs: 2 mcl; 5 mcl w/sc; 1 car (15).
 1 Hvy AC Plt: 3 AC (231); 3 AC (232).
 3 Lt AC Plt: 4 AC (222); 2 AC (223).
 Maint Sect: 1 mcl w/sc; 1 car (2/40); 2 trucks (2-ton).
 Co Trains: 1 car (15); 3 trucks (2-ton); 1 truck (medium); 1 truck (3-ton).

KStN 1112

1.11.1941

Motorcycle Infantry Company

Co Hqs: 4 mcl; 2 mcl w/sc; 1 car (15).
 3 Mcl Plt: Hqs Sect: 1 mcl; 2 cars (15).
 3 Mcl Sect: 4 mcl w/sc; 1 Infantry Squad with 2 LMG.
 1 Hvy Plt: Hqs Sect: 1 mcl; 1 mcl w/sc; 2 cars (15).
 2 HMG Sect: 8 mcl w/sc; 2 HMG.
 1 Mortar Sect: 3 trucks (70); 2 mortars (81mm).
 Maint Sect: 1 mcl w/sc; 1 car (2/40);
 Co Trains: 1 car (15); 1 truck (2-ton); 2 trucks (medium); 1 truck (3-ton).

KStN 1127

1.11.1942

Antitank Rifle Section: 1 mcl w/sc; 3 trucks (70); 3 ATR (28mm - towed on *Sd.Ah. 32/3*).

Motorized Heavy Company**KStN 1121**

1.11.1941

Co Hqs: 3 mcl; 2 mcl w/sc; 1 car (15).
 Lt Tele Sect *c*: 1 car (15).
 Maint Sect: 1 mcl w/sc; 1 car (2/40).
 Co Trains: 1 car (15); 1 truck (2-ton); 2 trucks (medium); 1 truck (3-ton).

KStN 1122a

1.12.1941

ATG Plt: Hqs Sect: 1 mcl; 1 mcl w/sc; 1 car (15).
 Gun Sect: 5 halftracks (10); 3 ATG (50mm - towed); 2 trailers (ammo); 3 LMG.

KStN 1123

1.11.1941

IG Plt: Hqs Sect: 1 mcl; 1 mcl w/sc; 1 truck (69).
 Gun Sect: 3 trucks (69); 2 lt IG (75mm - towed); 1 trailer (ammo).

KStN 1124

1.11.1941

Engr Plt: Hqs Sect: 1 mcl; 1 mcl w/sc; 1 car (15); 2 trucks (2-ton).
 4 Engr Sect: 1 truck (2-ton); 1 Engineer Section w/ 1 LMG.

KStN 1181

1.02.1941

Motorized Light Reconnaissance Column

Col Hqs: 3 mcl; 4 mcl w/sc; 1 car (15); 3 LMG.
 1 Sect: 1 mcl; 5 trucks (2-ton).
 2 Sect: 4 trucks (medium).
 Col Trains: 1 mcl w/sc; 2 trucks (medium).

NOTES:

This organization applied only to the SS-W Panzergrenadier Division.

The 1. SS Grenadier-Brigade had one Motorcycle Reconnaissance Company and one light Armored Car Platoon (ex-KStN 1162).

SS-PIONIER-BATAILLON
Motorized SS Combat Engineer Battalion

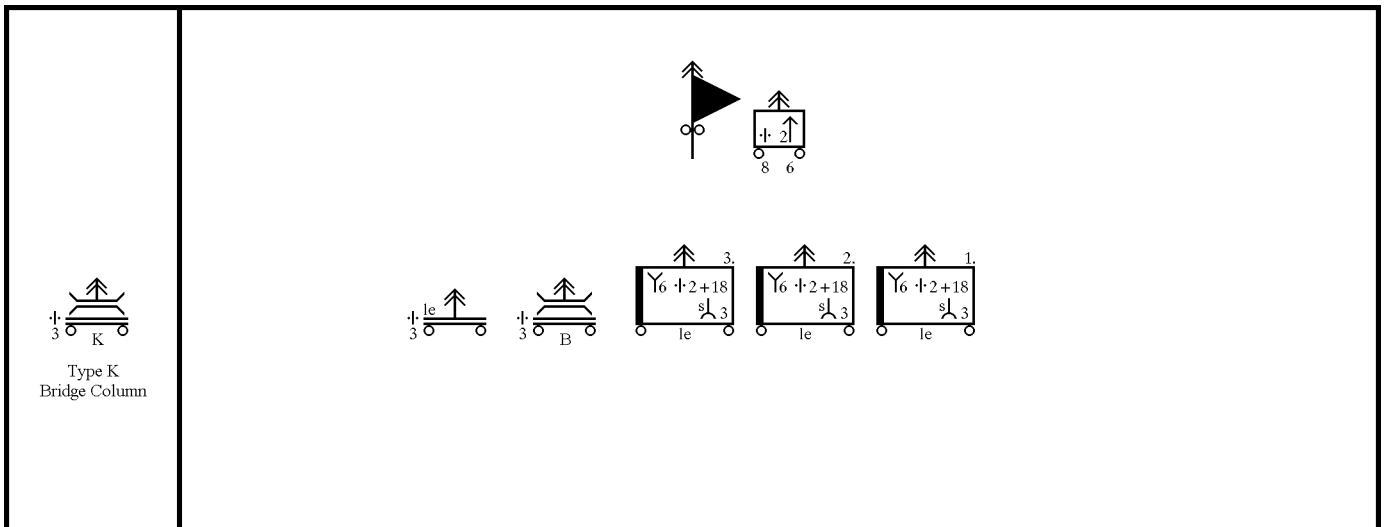

- KStN 703 *)** **Headquarters, Motorized Combat Engineer Battalion**
1.03.1943
Bn Hqs: 2 mcl; 2 mcl w/sc; 2 cars (light); 4 cars (15); 2 LMG.
Signal Det: 4 Lt Radio Sect *e*: 1 car (2).
1 Hvy Tele Sect *a*: 1 car (2); 1 truck (3-ton).
Bn Maint Det: 1 mcl w/sc; 1 car (2/40); 1 car (light); 2 trucks (3-ton).
Bn Trains: 1 mcl w/sc; 1 car (medium); 9 trucks (medium); 2 trucks (3-ton); 1 ambulance (31).
- SS KStN** **SS-Armored Scout Platoon**
14.10.1942
Hqs Sect: 2 cars (15).
2 Scout Sect: 1 radio armored car (232); 2 armored cars (222); 3 mcl w/sc.
Equipment Sect: 1 truck (3-ton).
- KStN 714(A)** **Motorized Light Combat Engineer Company**
1.04.1943
Co Hqs: 3 mcl; 1 mcl w/sc; 1 car (15).
Support Sect: 1 truck (1.5-ton); 1 truck (3-ton).
Signal Det: Hqs Sect: 1 car (15).
2 Lt Radio Sect *b*: 1 van (2-ton).
3 Engr Plt: Hqs Sect: 1 mcl; 1 mcl w/sc; 1 car (15); 1 truck (2-ton).
3 Sect: 2 truck (2-ton); 1 Combat Engineer Section w/ 2 LMG.
Maint Sect: 1 mcl w/sc; 1 car (2/40).
Co Trains: 1 mcl w/sc; 3 trucks (medium).
- KStN 728** **2 Engineer MG Sections: 2 trucks (70); 2 HMG.**
9.02.1943
- KStN 1127** **Antitank Rifle Section: 1 mcl w/sc; 3 trucks (70); 3 ATR (28mm - towed on *Sd.Ah.* 32/3).**
1.11.1942
- KStN 733 *)** **Motorized Type B Bridge Column**
1.03.1942
Col Hqs: 3 mcl; 1 car (light).
2 Bridge Plt: Hqs Sect: 1 mcl; 1 car (15); 1 LMG.
Pontoon Sect: 4 halftracks (7); 4 trailers (3 pontoons each).
Pontoon Sect: 4 trucks (4.5-ton); 4 trailers (3 pontoons each).
Trestle Sect: 2 trucks (4.5-ton); 2 trailers (trestles).
Transom Sect: 2 trucks (4.5-ton); 2 trailers (shore transoms).
Boat Sect: 1 truck (4.5-ton); 1 trailer.
1 Support Plt: Hqs Sect: 2 mcl w/sc.
Ramp Sect: 2 trucks (4.5-ton); 2 trailers (ramps).
Winch Sect: 1 truck (4.5-ton); 1 trailer (winch).
Col Trains: 1 truck (light); 2 trucks (medium).
- KStN 741** **Motorized Light Engineer Column**
1.03.1943
Col Hqs: 2 mcl; 1 mcl w/sc; 1 car (light).
1 Equipment Plt: 1 mcl; 1 mcl w/sc; 1 car (light); 5 trucks (medium); 1 van (42); 1 trailer (compressor); 1 trailer (cargo);
1 trailer (tool); 1 trailer (8-ton - long); 1 LMG.
1 Support Plt: 1 mcl; 1 mcl w/sc; 5 trucks (medium); 1 trailer (pile driver); 1 trailer (8-ton); 1 LMG.
Col Trains: 1 mcl w/sc; 1 truck (medium).
- KStN 737** **Motorized Type K Bridge Column**
1.04.1943
Col Hqs: 3 mcl; 1 car (light).
2 Bridge Plt: Hqs Sect: 1 mcl; 1 mcl w/sc.
Pontoon Sect: 4 trucks (3-ton); 1 LMG.
Trestle Sect: 2 trucks (4.5-ton); 1 trailer (motor boat).
Transom Sect: 4 trucks (4.5-ton).
Tread Sect: 4 trucks (3-ton).
1 Support Plt: Hqs Sect: 2 mcl w/sc.
Rubber Raft Sect: 3 trucks (medium); 1 LMG.
Equipment Sect: 2 trucks (medium).
Support Sect: 1 truck (medium); 1 truck (4.5-ton).
Main Sect: 1 mcl w/sc; 1 car (2/40).
Col Trains: 1 truck (light).

NOTES:

The SS-DR and SS-T had SS-Armored Scout Platoons.

The LSSAH and SS-W had 28mm antitank rifle sections.

The LSSAH had a Type K Bridge Column, the SS-DR and SS-T had Type B Bridge Columns, and SS-W did not have a bridge column.

LSSAH-DIVISION NACHRICHTEN-ABTEILUNG
Signal Battalion / LSSAH Division

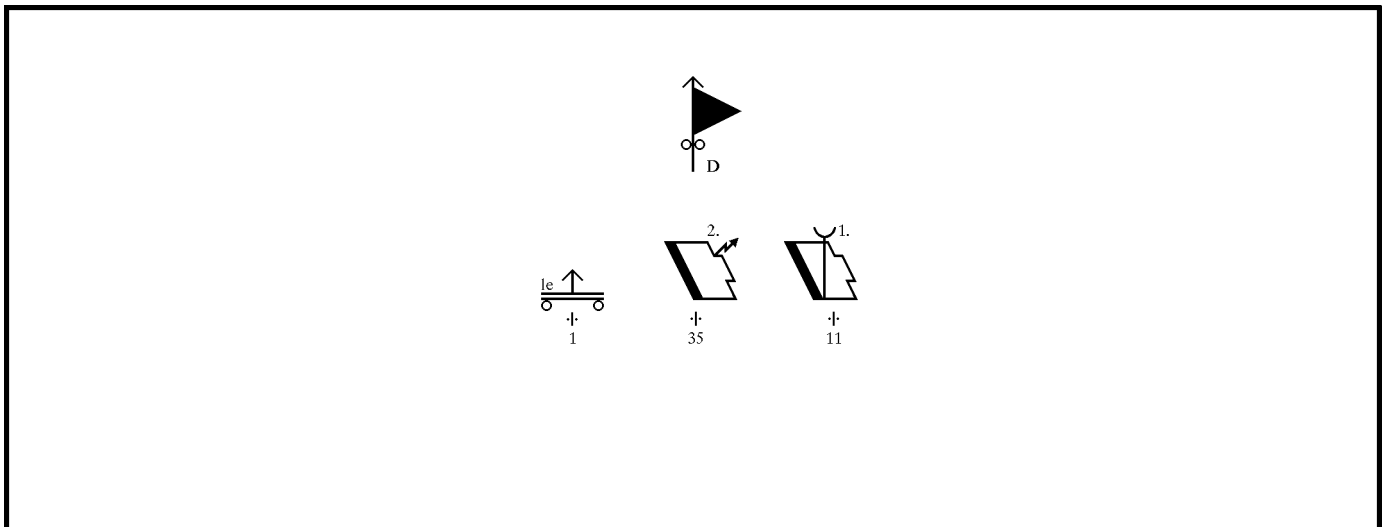
**KStN 805**

1.03.1943

Headquarters, Motorized Divisional Signal Battalion

Bn Hqs: 2 mcl; 1 car (light); 1 car (medium); 3 cars (15); 2 trucks (1.5-ton); 1 truck (medium); 2 LMG.
 Maint Det: 1 mcl w/sc; 1 car (2/40); 1 car (light); 2 trucks (3-ton).

KStN 976a

1.03.1943

Armored Telephone Company / Panzer Division

Co Hqs: 1 mcl; 1 mcl w/sc; 1 car (15); 1 truck (3-ton); 1 LMG.
 2 Armd Plt: Hqs Sect: 2 mcl; 1 car (15); 1 KK (2/2); 1 trailer (for KK 2/2); 1 LMG.
 1 Armd Tele Ops Sect: 1 SPW (251/11); 1 SPW (251/19).
 3 Armd Hvy Tele Sect: 2 SPW (251/11).
 1 Mot Plt: Hqs Sect: 2 mcl; 1 car (15); 1 KK (2/2); 1 trailer (for KK 2/2); 1 LMG.
 1 Tele Ops Sect a: 1 car (15); 1 van (17).
 4 Hvy Tele Sect a: 1 car (2); 1 van (23).
 1 Mot Plt: Hqs Sect: 2 mcl; 1 car (15); 1 KK (2/2); 1 trailer (for KK 2/2); 1 LMG.
 4 Hvy Tele Sect a: 1 car (2); 1 van (23).
 Maint Sect: 1 mcl w/sc; 1 car (2/40).
 Co Trains: 1 car (15); 5 trucks (medium).

KStN 971 *)

1.06.1942

Armored Radio Company / Panzer Division

Co Hqs: 1 mcl; 1 mcl w/sc; 1 car (15); 1 truck (3-ton); 1 LMG.
 1st Plt: Hqs Sect: 2 mcl; 1 SPW (251/3).
 1 Armd Radio Det: 3 Bef-Pz-III (141/2 equipped as command tanks).
 2 Armd Command Sect: 1 SPW (251/3).
 5 Armd Med Radio Sect a: 1 SPW (251/3).
 2nd Plt: Hqs Sect: 2 mcl; 1 SPW (251/3).
 6 Armd Med Radio Sect a: 1 SPW (251/3).
 2 Armd Med Radio Sect a/f: 1 SPW (251/3).
 3rd Plt: Hqs Sect: 2 mcl; 1 SPW (251/3).
 8 Armd Med Radio Sect a: 1 SPW (251/3).
 4th Plt: Hqs Sect: 2 mcl; 1 car (15); 1 truck (3-ton); 1 LMG.
 2 Mot Med Radio Sect b/f: 1 truck (2-ton).
 2 Mot Med Air Liaison Radio Sect: 1 van (2-ton).
 2 Pack Radio Sect: 1 car (1).
 1 Code Sect: 1 truck (3-ton).
 1 Signal Intelligence Sect: 1 van (3-ton).
 1 Replacement Tank Crew Sect: 1 truck (3-ton).
 Maint Sect: 1 mcl w/sc; 1 car (2/40); 1 truck (3-ton); 1 halftrack (11).
 Co Trains: 1 mcl; 1 car (1); 7 trucks (medium); 1 van (medium); 1 trailer (generator).

KStN 991

1.03.1942

Motorized Light Signal Transport Column a / Panzer Division

Col: 1 mcl w/sc; 1 car (light); 5 trucks (light); 1 van (light);
 3 trucks (medium); 2 vans (42); 1 trailer (generator); 1 LMG.

NOTES:

This organization applied only for the LSSAH.

SS-DIVISION NACHRICHTEN-ABTEILUNG
Signal Battalion / SS-Division

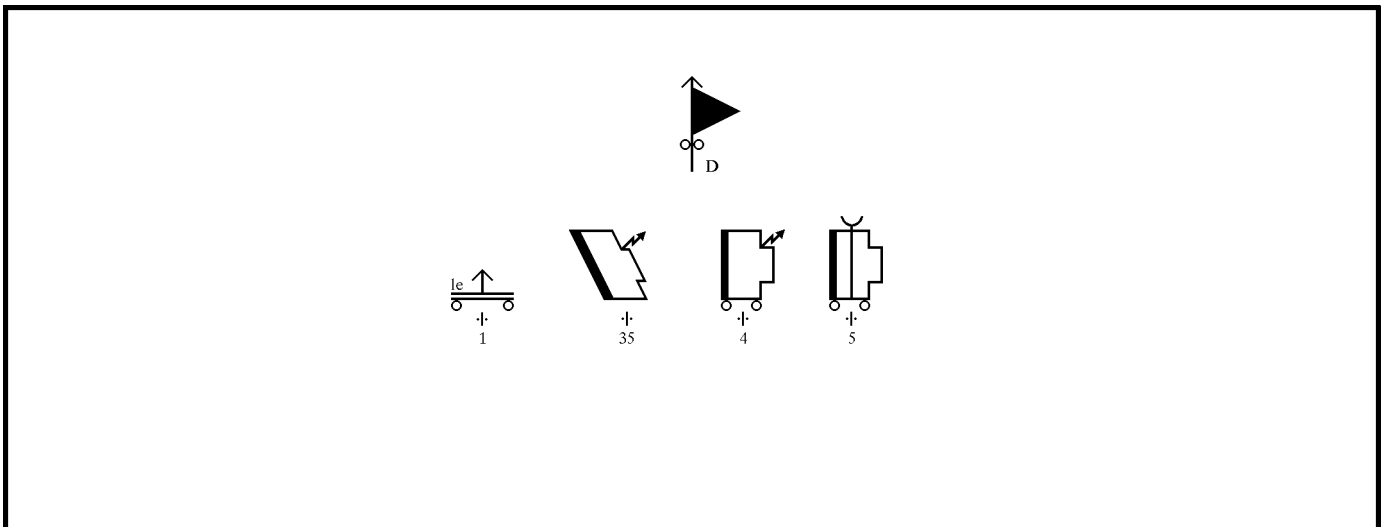

KStN 805
1.03.1943

Headquarters, Motorized Divisional Signal Battalion

Bn Hqs: 2 mcl; 1 car (light); 1 car (medium); 3 cars (15); 2 trucks (1.5-ton); 1 truck (medium); 2 LMG.
Maint Det: 1 mcl w/sc; 1 car (2/40); 1 car (light); 2 trucks (3-ton).

KStN 832
1.03.1942

Motorized Telephone Company a / Panzergrenadier Division

Co Hqs: 1 mcl; 1 mcl w/sc; 1 car (15); 1 truck (2-ton); 1 LMG.
1 Plt: Hqs Sect: 2 mcl; 1 car (15); 1 LMG.
3 Tele Ops Sect *a*: 1 car (15); 1 van (17).
4 Lt Tele Sect *b*: 1 car (15).
3 Plts: Hqs Sect: 2 mcl; 1 car (15); 1 LMG.
4 Hvy Tele Sect *a*: 1 car (2); 1 van (23).
Maint Sect: 1 mcl w/sc; 1 car (2/40).
Co Trains: 1 car (15); 3 trucks (light); 2 trucks (medium).

KStN 898 *)
1.03.1942

Motorized Radio Company a / Infantry Division

Co Hqs: 1 mcl; 1 mcl w/sc; 1 car (15); 1 truck (2-ton); 1 LMG.
1st Plt: Hqs Sect: 2 mcl; 1 car (15); 1 LMG.
2 Med Radio Sect *b*: 1 car (15); 1 van (17).
2 Pack Radio Sect: 1 car (2).
1 Code Sect: 2 cars (15).
2nd Plt: Hqs Sect: 2 mcl; 1 car (15); 1 LMG.
6 Med Radio Sect *a*: 1 car (15); 1 van (17).
3rd Plt: Hqs Sect: 2 mcl; 1 car (15); 1 LMG.
3 Med Radio Sect *a*: 1 car (15); 1 van (17).
1 Med Radio Sect: 1 car (15); 1 van (17).
1 Med Radio Sect: 1 car (15); 1 van (17).
Maint Sect: 1 mcl w/sc; 1 car (2/40).
Co Trains: 1 car (15); 3 trucks (light); 2 trucks (3medium); 1 van (42); 1 trailer (generator).

KStN 971 *)
1.06.1943

Armored Radio Company a / Panzer Division

Co Hqs: 1 mcl; 1 mcl w/sc; 1 car (15); 1 truck (3-ton); 1 LMG.
1st Plt: Hqs Sect: 2 mcl; 1 SPW (251/3).
1 Armd Radio Det: 3 Bef-Pz-III (141/2 equipped as command tanks).
2 Armd Command Sect: 1 SPW (251/3).
5 Armd Med Radio Sect *a*: 1 SPW (251/3).
2nd Plt: Hqs Sect: 2 mcl; 1 SPW (251/3).
6 Armd Med Radio Sect *a*: 1 SPW (251/3).
2 Armd Med Radio Sect *af*: 1 SPW (251/3).
3rd Plt: Hqs Sect: 2 mcl; 1 SPW (251/3).
8 Armd Med Radio Sect *a*: 1 SPW (251/3).
4th Plt: Hqs Sect: 2 mcl; 1 car (15); 1 truck (3-ton); 1 LMG.
2 Mot Med Radio Sect *b/f*: 1 truck (2-ton).
2 Mot Med Air Liaison Radio Sect: 1 van (2-ton).
2 Pack Radio Sect: 1 car (1).
1 Code Sect: 1 truck (3-ton).
1 Signal Intelligence Sect: 1 van (3-ton).
1 Replacement Tank Crew Sect: 1 truck (3-ton).
Maint Sect: 1 mcl w/sc; 1 car (2/40); 1 truck (3-ton); 1 halftrack (11).
Co Trains: 1 mcl; 1 car (1); 7 trucks (medium); 1 van (medium); 1 trailer (generator).

KStN 991
1.03.1942

Motorized Light Signal Transport Column a / Panzer Division

Col: 1 mcl w/sc; 1 car (light); 5 trucks (light); 1 van (light); 3 trucks (medium); 2 vans (42); 1 trailer (generator); 1 LMG.

NOTES:

The SS-T had a motorized telephone company and an armored radio company.

The SS-DR and SS-W had a motorized telephone and a motorized radio company.

NACHRICHTEN-KOMPANIE (mot) / SS-BRIGADE (mot)
Motorized Signal Company/ Motorized SS-Brigade

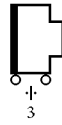

SS KStN
1.03.1943

Motorized SS Signal Company / SS-Infantry-Brigade (mot)

Co Hqs: 1 mcl; 1 mcl w/sc; 1 car (15); 1 truck (2-ton).
 1st Tele Plt: Hqs Sect: 2 mcl; 1 car (15); 1 LMG.
 2 Tele Ops Sect *a*: 1 car (15); 1 van (17).
 2 Lt Tele Sect: 1 car (2).
 6 Hvy Tele Sect *c*: 1 car (2); 1 van (23).
 2nd Radio Plt: Hqs Sect: 2 mcl; 1 car (15); 1 LMG.
 4 Med Radio Sect *a*: 1 car (15); 1 car (17).
 3rd Radio Plt: Hqs Sect: 2 mcl; 1 car (15); 1 LMG.
 Med Radio Sect *d*: 1 car (15); 1 van (medium).
 Lt Radio Sect *a*: 1 van (17).
 6 Pack Radio Sect *b*: 1 car (2).
 Maint Sect: 1 mcl w/sc; 1 car (2/40).
 Co Trains: 3 trucks (light); 4 trucks (medium); 1 trailer (generator - *Sd.Ah.* 23).

NOTES:

This organization applied for the 1st SS-Brigade.

DIVISIONS VERSORGUNGSDIENSTE – SS-PANZERGRENADIER-DIVISION
Divisional Support Services – SS Panzergrenadier Division

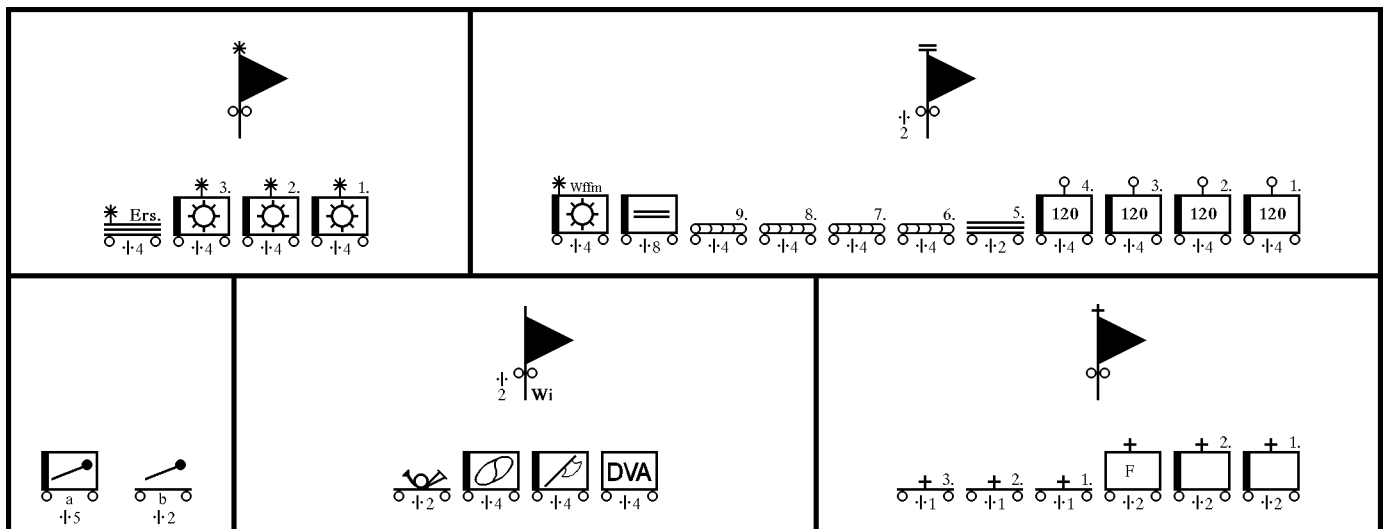

- KStN 1208 *) Headquarters, Motorized Divisional Supply Commander**
 1.03.1942
 Bn Hqs: 7 mcl; 2 mcl w/sc; 1 car (light); 2 cars (medium); 2 cars (11); 2 trucks (medium); 1 motor bus (light / 15 seats); 2 LMG.
 Ammunition Administration: 1 mcl; 1 car (light); 1 motor bus (medium / 22 seats).
 P.O.L. Administration: 2 cars (light).
 Battalion Maintenance Det:
 3 Maint Sect: 1 mcl w/sc; 1 car (2/40).
 Spare Parts Sect: 1 car (light); 2 trucks (3-ton).
 Bn Commissary Det: 1 car (light); 2 trucks (light); 3 trucks (medium).
- KStN 1231 *) Motorized Heavy Transport Column (60 tons)**
 1.03.1942
 Col Hqs: 1 mcl; 1 mcl w/sc; 1 car (light).
 2 sect: 5 trucks (medium); 1 LMG.
 2 Sect: 5 trucks (medium).
 Col Trains: 1 mcl w/sc; 2 trucks (light).
- KStN 1232 *) Motorized P.O.L. Transport Column (50 m³)**
 1.03.1942
 Col Hqs: 1 mcl; 1 mcl w/sc; 2 cars (light).
 4 Sect: 5 trucks (medium); 1 LMG.
 Col Trains: 1 mcl w/sc; 2 trucks (light).
- KStN 1217b *) Motorized Transport Company (120 tons)**
 1.11.1942
 Co Hqs: 1 mcl; 1 mcl w/sc; 2 cars (light).
 4 Plt: 10 trucks (medium); 2 LMG.
 Col Trains: 1 mcl w/sc; 4 trucks (light).
- KStN 1255 Motorized Supply Company**
 1.03.1942
 Co Hqs: 2 mcl w/sc; 1 car (light); 1 truck (light); 2 LMG.
 3 Supply Plt: 1 mcl w/sc; 3 trucks (medium); 2 LMG.
 1 Technical Plt: 1 mcl w/sc; 3 trucks (medium).
 Co Trains: 1 mcl; 1 truck (light).
- KStN 1052 Motorized Maintenance Company ⁽¹⁾**
 1.11.1941
 Co Hqs: 1 mcl; 1 car (light). [+4 LMG] ⁽²⁾
 3 Armorer Plt: 2 mcl w/sc; 1 truck (light); 4 trucks (medium).
 Co Trains: 1 mcl; 1 car (light); 3 trucks (light); 2 trucks (medium).
-
- KStN 1182 Headquarters, Motorized Maintenance Battalion**
 1.03.1943
 Bn Hqs: 5 mcl; 4 cars (light); 1 car (medium); 1 car (15).
 Bn Admin Det: 1 car (light); 2 trucks (light); 4 trucks (medium).
- KStN 1052 Motorized Motor Maintenance Company ⁽¹⁾**
 1.11.1941
 Co Hqs: 1 mcl; 1 car (light). [+4 LMG] ⁽²⁾
 2 Workshop Plt: 1 mcl w/sc; 1 car (light); 1 truck (light); 1 truck (heavy); 1 bus (medium/31 seats); 1 van (79); 1 halftrack (7);
 1 trailer (generator); 1 trailer (tool).
 Co Trains: 1 mcl; 1 car (light); 3 trucks (light).
- KStN 1231 *) Motorized Heavy Transport Column (60 tons) (for Spare Parts)**
 1.03.1942
 Col Hqs: 1 mcl; 1 mcl w/sc; 1 car (light).
 2 sect: 5 trucks (medium); 1 LMG.
 2 Sect: 5 trucks (medium).
 Col Trains: 1 mcl w/sc; 2 trucks (light).
-
- SS KStN Headquarters, Motorized SS Medical Battalion**
 1.11.1942
 Bn Hqs: 1 mcl; 3 cars (medium).
 Lt Tele Sect: 1 car (15).
 Maint Sect: 1 mcl w/sc; 1 car (2/40); 1 car (medium); 2 trucks (3-ton).
- SS KStN Motorized Medical Company "o"**
 1.01.1943
 Co Hqs: 2 mcl; 3 cars (15); 3 trucks (medium).
 Lt Tele Sect c: 1 car (15).
 Admin Sect: 1 mcl w/sc; 1 car (medium); 1 truck (medium).
 Maint Sect: 1 mcl w/sc; 1 car (2/40); 1 truck (medium).
 2 Medical Plt: 1 mcl w/sc; 2 cars (medium); 11 trucks (medium); 4 ambulances (31).
- KStN 1342 Motorized Field Hospital**
 1.01.1943
 Hqs Sect: 1 mcl w/sc; 2 cars (medium); 2 trucks (medium); 1 motor bus (light / 15 seats);
 1 trailer (generator - 15/18 kVa); 1 trailer (shower - *Sd.Ah. 11*).
 2 Plt: 1 car (light); 2 trucks (medium); 1 van (medium); 1 ambulance; 1 motor bus (light / 15 seats).
- KStN 1365 Motorized Ambulance Platoon**
 1.11.1941
 Plt Hqs: 1 car (light); 2 trucks (light). [+1 LMG] ⁽¹⁾
 3 Sect: 5 ambulances (31).

DIVISIONS VERSORGUNGSDIENSTE – SS-PANZERGRENADIER-DIVISION
Divisional Support Services – SS Panzergrenadier Division

SS KStN 1.01.1943	Headquarters, Motorized SS Administrative Battalion ⁽³⁾ Bn Hqs: 3 mcl; 5 cars (medium); 1 motor bus (modified for office use); 2 LMG. Lt Tele Sect: 1 car (15). Bn Maint Det: 1 mcl w/sc; 1 car (2/40); 2 truck (medium). Bn Hqs Trains: 2 mcl w/sc; 1 car (light); 2 trucks (light); 3 trucks (medium); 2 trucks (heavy); 1 ambulance (31).
SS KStN 1.01.1943	Motorized SS Commissary Office Hqs Sect: 2 mcl w/sc; 1 car (light). 1st Plt (Issue): 1 car (light); 1 LMG. 2nd Plt (Intake): 1 mcl w/sc; 1 LMG. 3rd Plt (Intake): 1 mcl w/sc; 1 LMG. Maint Sect: 1 truck (heavy). Co Trains: 1 car (light); 23 trucks (medium); 3 trucks (heavy); 1 LMG.
SS KStN 1.01.1943	Motorized SS Butcher Company Co Hqs: 1 mcl w/sc; 1 car (light). Sausage Plt: 1 car (light); 2 LMG. Slaughter Plt: 1 mcl; 1 mcl w/sc; 2 LMG. Maint Sect: 1 truck (heavy); 1 trailer (generator - 25/30 kVa). Motor Pool: 10 trucks (medium); 2 refrigeration vans (medium); 1 water truck; 7 trucks (heavy);
SS KStN 1.01.1943	Motorized SS Baker Company Co Hqs: 2 mcl; 2 mcl w/sc; 1 car (medium). 1st Plt: 1 trailer (dough mixer); 1 trailer (dough roller); 2 trailers (oven); 1 trailer (generator - 220V, 6Kw); 1 LMG. 2nd Plt: 1 mcl; 2 trailers (oven); 1 LMG. 3rd Plt: 2 trailers (oven); 1 LMG. Maint Sect: 1 truck (heavy). Co Trains: 1 mcl; 1 car (light); 1 LMG. Motor Pool: 26 trucks (medium); 9 trucks (heavy).
KStN 2251 1.02.1941	Motorized Field Post Detachment ⁽⁴⁾ Det: 1 car (medium); 1 bus (medium/33 seats); 2 vans (medium).
KStN 2033b 1.03.1942	Motorized Military Police Detachment "b" ⁽⁴⁾ Det Hqs: 4 mcl w/sc; 2 cars (light); 1 truck (light). 2 MP Plt: 6 mcl; 5 cars (light); 2 LMG.
KStN 2035 1.01.1943	Motorized Military Police Company "a" ⁽⁴⁾ Co Hqs: 3 mcl; 3 cars (medium). 2 Traffic Control Plt: Hqs Sect: 2 mcl; 1 mcl w/sc; 1 car (medium); 1 truck (light). 1 Lt Tele Sect c: 1 car (15). 2 Sect: 4 mcl; 3 mcl w/sc; 1 LMG. 1 Sect: 4 mcl; 3 mcl w/sc. 1 Support Plt: Hqs Sect: 2 mcl; 1 car (medium); 1 truck (light). 1 Scout Sect: 3 mcl; 2 mcl w/sc. 1 Traffic Sign Sect: 2 mcl w/sc; 1 car (medium). 1 Engineer Sect: 1 mcl; 2 cars (15). Co Maint Sect: 1 mcl w/sc; 1 car (2/40). Co Trains: 1 mcl; 1 car (light); 3 trucks (light); 1 bus (medium/33 seats); 1 LMG.

NOTES:

- (1) The Motorized Maintenance Company had a footnote that stated that per division only one of the companies had an armorer platoon. The others did not. If there was an Armorer Company (*Wffm*) present, none of the Maintenance Companies had an armorer platoon.
- (2) Organization diagrams often show more LMG in the service units than the original KStN authorized. Therefor they must have authorized at some time by General Army Orders (Allgemeine Heeresmitteilungen.) Where the exact location within the unit is unknown, these additional LMG are placed in square brackets at the end of the headquarters section.
- (3) This KStN shows certain members of the staff of the Administration Battalion as part of the Divisional Headquarters, and were merely indicated in this organization for their function within the battalion staff.
- (4) The Field Post and the Military Police units were fully integrated into the Division (Brigade) Headquarters, and were furthermore attached for disciplinary matters, administration, and rations.

Divison	60-ton Column	90-ton Company	120-ton Company	P.O.L. Column	Supply Company	Maint. Company	Armorer Company	Spare Parts Column	Medical Company	Field Hospital	Ambulance Platoon	Commissary Office	Butchery Company	Bakery Company	Field Post	MP Unit
LSSAH	–	–	8	–	1	3 ⁽¹⁾	1	1	2	1	3	1	1	1	1	Company
SS-DR	9	–	–	4	1	3	1	1	2	1	3	1	1	1	1	Company
SS-T	1	–	4	4	1	3	1	1	2	1	3	1	1	1	1	Company
SS-W	3	–	–	3	1	2	1	1	1	1	2	1	1	1	1	Detachment
RFSS Brig	1	–	–	–	–	–	–	–	–	–	–	–	–	–	1	–
1. SS Brig	5	–	–	1	1	1	–	–	1	–	2	1	Platoon ⁽²⁾	Platoon ⁽²⁾	1	Detachment

NOTES:

- (1) One of the Motorized Maintenance Companies in LSSAH was a Tank Maintenance Company.
- (2) One conglomerate platoon with various elements of the entire company.

SOURCES AND REFERENCES

UNPUBLISHED

<i>Bundesarchiv-Militärarchiv (German Military Archives), Freiburg/Br.</i>	<i>U.S. National Archives, Washington, D.C.</i>
RHD 4/273 "Muster für taktische Zeichen des Heeres" Heeresdruckvorschrift (H.Dv) 272, dated 23.05.1943	Film T-78, Roll 619 "Panzerkampfwagenlage"
RH 10/132 to 133 "Kriegstagebuch General der Panzertruppen"	Film T-78, Roll 620 "Sturmgeschützlage"
RHD 11/1e "Gültigkeitsliste der Kriegstärke- und Ausrüstungsnachweisungen, Stand 1.4.1943"	Film T-78, Roll 719 "Zustandsberichte Waffen-SS Divisionen"
RHD 11/1 – 11/53 "Kriegstärkenachweisungen"	Film T-78, Roll 719 "Zustandsberichte Waffen-SS Divisionen"
RH10/63 "Pak-(sf)-Lage"	

PUBLISHED

BEIERSDORF, H. "KFZ-Anhänger der Wehrmacht 1935 – 1945" Podzun-Pallas, Friedberg, 1994.	KOCH, H.A. "Flak" Podzun, Bad Nauheim, 1965.	PETTER, D.P. "Pioniere - Entwicklung einer deutsche Waffengattung" Wehr & Wissen, Darmstadt, 1963.
BUCHNER, A. "Das handbuch der deutschen Infanterie, 1939 – 1945" Podzun-Pallas, Friedberg, 1987.	KOSAR, F. "Leichte Feldgeschütze" Lehmans, Munich, 1971.	RICHTER, K. C. "Die bespannten Truppen der Wehrmacht" Motorbuch, Stuttgart, 1997.
— "Der Sanitätsdienst des Heeres" Nebel, Eggolsheim, 2002.	— "Mittlere Feldgeschütze" Lehmans, Munich, 1973.	Von SENGER und ETTERLIN, F.M. "Die Panzergrenadiere" Lehmans, Munich, 1961.
CHAMBERLAIN, P., DOYLE, H.C., JENTZ, T. "Encyclopedia of German Tanks of World War II" Arco Publishing, New York, 1978.	— "Schwere Geschütze und Eisenbahngeschütze" Bernard und Graefe, Munich, 1978.	— "Die deutschen Geschütze 1939 – 1945" 3rd Edition Bernard & Braede, Bonn, 1998.
EMDE, J. "Die Nebelwerfer" Podzun-Pallas, Friedberg, 1979.	— "Infanteriegeschütze und Rückstossfreie Leichgeschütze" Motorbuch, Stuttgart, 1979.	SPIELBERGER, W. "Die Panzerkampfwagen I und II und ihre Abarten" Motorbuch, Stuttgart, 1974.
DOYLE, H.C., and KLIMENT, C.K. "Czechoslovak Armored Fighting Vehicles: 1918 – 1945" Bellona, Watford, Herts., 1979.	MEHNER, K. "Die Deutsche Wehrmacht 1939 – 1945" = Führung und Truppen = Militair-Verlag Patzwall, Norderstedt, 1993.	— "Der Panzerkampfwagen III und seine Abarten" Motorbuch, Stuttgart, 1974.
ENGELMANN, J. "Das Buch der Artillerie, 1939 – 1945" Podzun-Pallas, Friedberg, 1983.	Militärgeschichtliches Forschungsamt "Das Deutsche Reich und der Zweiten Weltkrieg" Deutsche Verlags-Anstalt, Stuttgart, 1978 – 2001.	— "Die gepanzerten Radfahrzeuge des Deutschen Heeres" Motorbuch, Stuttgart, 1974.
ENGLEMANN, J., and SCHEIBERT, H. "Deutsche Artillerie, 1934 – 1945" Starke, Limburg/Lahn, 1974.	MILSOM, John "German Military Transport of World War II" Arms & Armour Press, London, 1975.	— "Der Panzerkampfwagen IV und seine Abarten" Motorbuch, Stuttgart, 1975.
ERB, H. "Kradschützen" Motorbuch, Stuttgart, 1981.	MUELLER-HILLEBRAND, B. "Das Heer 1933-1945" E.S. Mittler, Darmstadt, 1954 E.S. Mittler, Frankfurt/Main, 1965 – 1969.	— "Die Halbkettenfahrzeuge des Deutschen Heeres" Motorbuch, Stuttgart, 1976.
FRANK, R. "Lastkraftwagen der Wehrmacht" Podzun-Pallas, Friedberg/H., 1992.	NEHRING, W. "Die Geschichte der deutsche Panzerwaffe 1916–1945" Motorbuch, Stuttgart, 1974.	— "Die Motorisierung der Deutschen Reichswehr, 1920 – 1935" Motorbuch, Stuttgart, 1979.
— "Personenkraftwagen der Wehrmacht" Podzun-Pallas, Friedberg/H., 1993.	— "Die deutschen gepanzerten Truppen bis 1945" Maximilian, Herford, 1965.	— "Die Panzer-Kampwagen 35(t) und 38(t) und ihre Abarten einschließlich der tschechoslowakischen Heeresmotorisierung, 1920 – 1945" Motorbuch, Stuttgart, 1980.
GANDER, T.J. "Field Rocket Equipment" Almark, London, 1972.	NIEHAUS, W. "Die Nachrichtentruppen 1914 bis heute" Motorbuch, Stuttgart, 1980.	TESSIN, G. "Verbände und Truppen der Deutschen Wehrmacht und Waffen-SS im Zweiten Weltkrieg" E.S. Mittler, Frankfurt/Main, 1965 – 1970. Biblio, Osnabrück, 1972 – 1988.
HAHN, J. "Waffen und Geheimwaffen des deutschen Heeres, 1933 – 45" Bernhard und Graefe, Koblenz, 1986/87.	OSWALD, W. "Kraftfahrzeuge und Panzer der Reichswehr, Wehrmacht und Bundeswehr" 11th Edition Motorbuch, Stuttgart, 1982.	TM-E 30-451 "Handbook on German Military Forces" War Department, Washington, D.C., 15 March 1945.
JENTZ, T. "Panzertruppen 1943 – 1945" Schiffer Military History, Atglen, PA, 1996.	PAWLAS, K.L. "Datenblätter für Heeres-Waffen, Fahrzeuge und Gerät 1944" (Dokumentenmtation W 127) Karl L. Pawlas, Nürnberg, 1976.	Zentral Museum & Zentralarchiv der Pioniere "Deutsche Pioniere 1939 – 1945" Kurt Vowinckel, Neckargemünd, 1976.
KEILIG, W. "Das Deutsche Heer 1939-1945" [Loose-leaf collection, issued periodically] Podzun, Bad Neuheim, 1956 onwards.		

INTRODUCTION TO GERMAN SOFT-SKINNED MOTOR VEHICLES

Identification and Numbering System

The German Wehrmacht identified its motor vehicles by make, by type, by load, by mobility, by purpose, by number of seats, and/or by number. The latter, *Kraftfahrzeug (Kfz.)* and *Sonder Kraftfahrzeug (Sd.Kfz.)* numbers, indicated the purpose but not manufacturer of the vehicle. Early in the war, this series of numbers were reasonably well adhered to, although some vehicles were only classified by their load and mobility. As the war continued, the numbering system fell into disuse. The details of the numerical classifications are given on the next pages. The classifications were:

Kfz. No. Nomenclature

- 1 – 10 light personnel carriers (*le. PKW*)
- 11 – 20 medium personnel carriers (*m. PKW*)
- 21 – 30 heavy personnel carriers (*s. PKW*)
- 31 – 40 light load carriers (*le. LKW*)
- 41 – 50 medium load carriers (*m. LKW*)
- 51 – 60 heavy load carriers (*s. LKW*)
- 61 – 70 light cross-country load carriers (*le. gl. LKW*)
- 71 – 80 medium cross-country load carriers (*m. gl. LKW*)
- 81 – 90 heavy cross-country personnel carriers (*s. gl. PKW*),
and, light cross-country load carriers (*le. gl. LKW*)

The heavy personnel carrier and the light load carrier had the same numbers. Same chassis, different bodies.

Classifications did not always correspond to the actual usage. Mobility for personnel and load carriers, whether military or commercial versions, was defined either as cross-country (indicated by the prefix “*geländegängig*”, abbreviated to “*gl.*”, i.e. cross-country), or road-bound, in which case either the suffix “*(o.)*” was added, or the suffix was omitted altogether.

Commercial vehicles could be directly purchased from the manufacturer, or, upon mobilization, requisitioned from the civilian economy. Indeed 63% of all motor vehicles in the German Army were requisitioned by September 1939.

German Load Carriers

Load carriers came in two versions (truck, i.e. open/with a bed; and van, i.e. closed/with a body instead of a bed), and in two types (commercial and military). As indicated above, the Germans used both numbered and unnumbered series of load carriers. Load carriers with and without “*Kfz.*” numbers came in three different load classifications:

- Light up to 2-ton
- Medium 3-ton
- Heavy 4.5-ton and over.

Load carriers with over a 5-ton load factor were only bought in the commercial versions.

German Commercial Load Carriers in Military Use

up to 2-ton (light)	Adler	W61
	Borgward	L1400
	Daimler-Benz	L1500, L1500S, L1500A
	Phanomen	Granit 25H; 1500S, 1500A
	Opel	Blitz 2,5-32
	Steyr (Ost. Daimler)	1500A/01, 1500A/02, 2000A
3-ton (medium)	Borgward	B3000S, B3000A
	Daimler-Benz	L3000, L3000S, L3000A
	Ford	G21T; V3000, V3000S
	KHD (Magirus)	3000S, 3000A
	MAN	E2; E3000
	Opel	Blitz 3,6-36S, Blitz 6700A
4.5-ton (heavy)	Büssing-NAG	4500S, 4500A
	Daimler-Benz	L4500S, L4500A
	Gräfe & Stift	V7DW
	MAN	ML4500S, ML4500A
6.5-ton	Büssing-NAG	6500
	Daimler-Benz	L6500
	Krupp	LD6,5
	MAN	F4
	Vomag	6LR-647, 6LR-652
	Tatra	6500A
9-ton	Büssing-NAG	801, 802
	Faun	L9000D567

German Personnel Carriers

Personnel carriers, with or without numbers, were also classified according to their mobility and engine size:

- Light up to 1500cc
- Medium up to 3000cc
- Heavy over 3000cc

Personnel carriers were either civilian or military. Civilian and later also military vehicles were identified by the engine size – and sometimes the number of seats.

German Motorcycles

There were a multitude of motorcycle types in the German Army, classified according to engine size:

- Light up to 350cc
- Medium up to 500cc
- Heavy over 500cc

Motorcycles came in solo and sidecar versions. For the heavy motorcycles with sidecars, the sidecar wheel was power-driven. Some motorcycles had a light machine-gun mounted on the sidecar. The side cars were also used to carry light mortars, ammunition, as well as personnel.

The Einheits-Vehicle-Program

The Einheits Program was an attempt by the German Armed Forces in the 1930s to produce a series of standardized vehicles. They were based on complicated 4 x 2, 4 x 4, and 6 x 4 chassis, with varying bodies, each conceived for a specific role.

Four chassis were finally produced. They were designated the light (*le. E-PKW*), the medium (*m. E-PKW*), as well as the heavy (*s. E-PKW*) personnel carriers. The fourth was the light load carrier (*le. E-LKW*, also known as the “*Einheits-Diesel*”). This light load carrier, produced between 1937 and 1940, had a 6 x 6 chassis capable of transporting 2.5-tons, and was powered by a diesel engine, (one of the few WWII German vehicles so powered).

Early Einheits-PKW all had stub axles on both sides for the spare wheels, which were supposed to assist the vehicles in crossing rough terrain. This feature was dropped in later models.

Light load carrier chassis were also fitted with passenger bodies. A typical example of this was the *le. Einheits-LKW*, and later the Steyer 1500.

The Einheits Vehicle Program ran into considerable difficulties owing to production and maintenance complications. The design proved too sophisticated for field use, where maintenance and spare parts were in short supply. The complicated two-axle steering caused particular problems in maintenance. The *le. Einheits-LKW* proved the only one that was a successful design.

The Schell Vehicle Program

The Einheits Program could not meet the motor vehicle needs of the German Armed Forces. In 1938, the Schell Program was initiated. It standardized the number of Einheits vehicles at four, (see paragraph above), and provided a limited number of alternative commercial vehicles with all-wheel drive. It reduced the large variety of models in both commercial and military production from 113 to 30 load carriers, from 52 to 10 personnel carriers, and from 150 to 30 motorcycles, which, as an added benefit, enabled the German Army to commandeer civilian vehicles in time of need without drastically complicating the replacement and spare parts situation. The Schell Program vehicles did not always have the engine performance required for military use.

Neither the Einheits nor the Schell Programs provided enough vehicles for the expanding German Armed Forces. However, no solution was ever found for this problem, and Germany was severely handicapped by a lack of motor vehicles in World War II. Even the incorporation of captured enemy vehicles and the production facilities of occupied countries was unable to remedy this problem.

The Raupenschlepper Ost (RSO)

The Russian Campaign quickly demonstrated that German wheeled vehicles were totally inadequate when it came to moving through mud and snow. This lack of good cross-country mobility led to the development of the Raupenschlepper Ost, created to meet the needs of the infantry for a fully-tracked motor vehicle that could move in all terrain. It was ideal also because it did not move very much faster than the marching infantry. This family of vehicles was produced without the standard identifying numbers being allocated.

The Maultier

The lack of good cross-country mobility also led to field improvisations. One of which was so successful that it was produced in large amounts by German industry. The Maultier was basically a truck with tracks and drive train components similar to that of a light tank instead of a rear axle and wheels. The Germans produced two weight classes, namely the Sd.Kfz. 3 based on the medium truck, (initially with a 2-ton payload, then increased to 3 tons) and the Sd.Kfz. 3/5, based on the 4.5-ton truck, (initially with a 4-ton payload, then increased to 4.5 tons).

The Schwere Wehrmachtsschlepper

A simplified and standardized 6-ton halftrack began production in late 1943. Production was low, with only 1000 being produced during the war.

GERMAN NUMBERED MOTORIZED SOFT-SKINNED VEHICLES

Kfz.	German Nomenclature	Description	Makes & Models
1	le gl PKW (‘Kübelwagen’)	light cc personnel carrier (3 and 4-seater) Hanomag - all models	le. Einheits-PKW BMW 303, 309, 315, 319, 3/15, 4/20PS Daimler-Benz 170-V Dixie 3/15 Opel P-4 Skoda Popular 1100 Steyr 250 Volkswagen Type 82, 87, etc.
1/20	le gl schwimm-PKW	light amphibious cc personnel carrier (4-seater)	Volkswagen Type 128 and 166
2	le Nachrichten-Kw	light cc signals carrier	le. Einheits-PKW
2/1	le Fernsprech-Kw	light cc telephone carrier	BMW 309, 319, 3/15, 4/20
2/2	le Funk-Kw	light cc radio carrier	Hanomag - all models
2/40	le Instandsetzungs-Kw	light cc maintenance section carrier (all 2 seaters with equipment storage in the back)	Daimler-Benz 170-V Volkswagen Type 82, 87, etc.
3	le Messtrupp-Kw	light cc calibration section carrier	le. Einheits-PKW BMW 309 Daimler-Benz 170-V Steyr 250 Volkswagen Type 82, 87, etc.
4	le Truppen-Luftschutz-Kw	light cc anti-aircraft carrier (dual MG)	le. Einheits-PKW
5	m gl Kessel-Kw	medium cc tanker	m. Einheits-PKW
11	m gl PKW	medium cc personnel carrier	m. Einheits-PKW
12	m gl PKW mit Zughaken	medium cc personnel carrier with towing hook (for 37mm ATG, 75mm IG, ammo trailers)	Adler 12N, 3-Gd Daimler-Benz 200, 260, 290, 320 Phänomen Granit 25 Wanderer W-11, W-23S
13	m gl gp PKW (MG)	early armored medium cc car (with one MG)	Adler Standard 6
14	m gl gp PKW (Funk)	early armored medium cc radio car (no armament)	
15	m gl PKW	medium cc personnel carrier	m. Einheits-PKW
15	m gl PKW mit Gerätkasten	medium cc carrier with equipment boxes	Auto Union / Horch 830-R
15/1	m gl Nachrichten-Kw	medium cc signals carriers	Daimler-Benz 340-WK, L1500A
15/1	m gl Fernsprech-Kw	medium cc telephone carrier	Horch 830-R, 830-BL
15/2	m gl Funk-Kw	medium cc radio carrier	Steyr 250
15/4	m gl Funk-Kw	medium cc radio carrier	Stoewer M-12-RW
15/5	m gl Funk-Kw	medium cc radio carrier	
15/6	m gl Funk-Kw	medium cc radio carrier	
15/7	m gl Funk-Kw	medium cc radio carrier	
17	m gl Fernschreibe-Kw	medium cc telex carrier	
16	m gl Meßstelle-Kw	medium cc calibration station carrier	
16	m gl Meßtrupp-Kw	medium cc calibration section carrier	
16/1	m gl Vorwarner-Kw	medium cc advanced warning section carrier	
17	kl Verstärker-Kw	small cc amplifier van	m. Einheits-PKW
17	kl Kabelmess-Kw	small cc wire calibration van	Auto Union / Horch 830-R
17	kl Fernsprechbetriebs-Kw	small cc telephone operations van	
17/1	kl Funktrupp-Kw	small cc radio section van	
17/2	kl Fernsprechtrupp-Kw	small cc telephone section van	
17/3	kl Funk-Kw	small cc radio van	
18	s gl PKW	heavy cc personnel carrier	m. Einheits-PKW
18	Gefechts-Kw (mit Gerätkasten & Zughaken)	heavy cc carrier (combat) (with equipment boxes and towing hook)	s. Einheits-PKW Daimler-Benz 200, L1500A Wanderer W 11, W 14
19	Fernsprechbetriebs-Kw	cc telephone exchange van	Krupp L2H-43, Krupp L2H-143
	Fernsprech-Kw	cc telephone van	
	Funk-Kw	cc radio van	
21	s gl PKW (Kommandeurwagen)	heavy cc staff car (sedan or cabrio)	Daimler-Benz G-4 Krupp L2H-143 Cabrio Steyr 640, 1500A Praga Skoda
23	Fernsprech-Kw	cc telephone equipment van	s. Einheits-PKW
24	Verstärker-Kw	cc amplifier equipment van	
31	Sanitäts-Kw (‘Sanka’) [also: Kranken-Kw (‘KrKw’)]	cc ambulance van	s. Einheits-PKW Phänomen Granit 25H Steyr 640, 1500A Adler W-61K Daimler-Benz L1000, L1500E Ford G917, G987, 997, V3000S, V3000A
42	Sammler-Kw	generator / accumulator / battery van	Krupp L3-M42
	Sammlerwerkstatt-Kw	generator repair van	m. LKW (o.)
	Nachrichtenwerkstatt-Kw	signals repair van	
	Werkstatt-Kw	workshop van	
43	Flakauswert-Kw	anti-aircraft evaluation van	
44	Sauer- und Stickstoff-Erzeugungs-Kw	Oxygen and Nitrogen generation van	
51	Werkstatt-Kw	workshop van	m. LKW (o.) s. LKW (o.)

NOTES:

The early armored cars (*Kraftfahrzeug 13* and *14*) were obviously not soft-skinned vehicles. It is not clear why they were included within this listing and not in the special military motor vehicle (*Sonderkraftfahrzeug*) listing.

GERMAN NUMBERED MOTORIZED SOFT-SKINNED VEHICLES

Kfz.	German Nomenclature	Description	Makes & Models
61	gr Nachrichten-Kw gr Schlüssel-Kw gr Funk-Kw gr Funkbetriebs-Kw gr Fernsprechbetriebs-Kw gr Fernschreib-Kw gr Verstärker-Kw gr Peil-Kw gr Meßtrupp-Kw	large cc signal van large cc code van large cc radio van large cc radio operations van large cc telephone operations van large cc telex van large cc amplifier van large cc sound-ranging equipment van large cc calibration section van	Einheits-Diesel Daimler-Benz G-3a, LG 3000 Büssing-NAG G-31, G500A, G500S, 4500S, 4500A Magirus M-206, M-30, S3000, A3000 Borgward G.W., B3000S, B3000A
61/1	gr Funk-Kw	large cc radio van	
62	gr Nachrichten-Kw gr Fernsprechbetriebs-Kw gr Funk-Kw gr Wetter-Kw gr Druckerei-Kw gr Schall-Aufnahme-Kw gr Schall-Auswertungs-Kw gr Vermessung-Auswertungs-Kw gr Licht-Auswertungs-Kw gr Stabs-Auswertungs-Kw	large cc signals van large cc telephone operations van large cc radio van large cc weather van large cc printing van large cc sound recording van large cc sound evaluation van large cc calibration evaluation van large cc flash evaluation van large cc evaluation command van	
63	gr Nachrichten-Kw gr Meß-Stellen- und Gerät-Kw gr Vermessungs-Gerät-Kw gr Lichtmeß-Stellen-Kw gr Lichtmeß-Gerät-Kw gr Schallmeß-Stellen-Kw gr Schallmeß-Gerät-Kw gr Vorwarner-Kw gr Vermessungsgerät-Kw	large cc signals van large cc calibration station and equipment van large cc calibration equipment van large cc flash ranging station van large cc flash ranging equipment van large cc sound ranging station van large cc sound ranging equipment van large cc advanced warning equipment van large cc calibration equipment van	
68	Funkmast-Kw Fernsprech-Kw	cc radio antenna van cc telephone carrier	Einheits-Diesel Krupp L2H-43, L2H-143 Magirus M-206 Opel Blitz A
68/1	Funkmast-Kw	cc radio antenna van	
69	Protz-Kw	cc prime-mover for light guns	s. Einheits-PKW
70	Mannschafts-Kw	cc personnel carrier	Krupp L2H-43, L2H-143
71	Truppen-Luftschutz-Kw s Truppenluftschutz-Kw	cc anti-aircraft carrier heavy cc anti-aircraft carrier	Mercedes-Benz L1500A
72	Fernsprechbetriebs-Kw Fernsprech-Vermittlungs-Kw Fernschreib-Kw Fernschreib-Vermittlungs-Kw Verstärker-Kw Funk-Kw (a & b) Funkbetriebs-Kw Funkhorch-Kw Befehls-Kw Druckerei-Kw m Wetter-Kw	cc telephone operations van cc telephone exchange van cc telex van cc telex exchange van cc amplifier van cc radio van cc radio operations van cc radio interception van cc command van cc printing van cc weather van	Henschel 33-D1 Magirus 33-G1 Krupp L3H-63, L3H-163 Büssing-NAG III GL6
72/1	Fernschreib-Kw	cc telex van	
74	Flak-Meßtrupp-Kw I & II	cc anti-aircraft calibration section van	
76	Beobachtungs-Kw	cc observation carrier	Daimler-Benz G-3a
77	Feldkabel-Kw Fernsprech-Kw Fernsprechbau-Kw	cc field cable carrier cc telephone carrier cc telephone construction carrier	Büssing-NAG G-31 Magirus M-206
79	Werkstatt-Kw	cc workshop van	Henschel 33-D1 Magirus 33-G1 Krupp L3H-63, L3H-163
81	le Flak-Kw	cc prime-mover for light anti-aircraft guns	s. Einheits-PKW
83	le Scheinwerfer-Kw I & II	cc prime-mover for light searchlights, with generator	Krupp L2H-42, L2H-143
92	Mannschaft-Entgiftungs-Kw	cc personnel decontamination van	Henschel 33-D1, 33-G1
93	Bekleidungs-Entgiftungs-Kw	cc clothing decontamination van	
94	Wasser-Kw (Kessel)	cc decontamination van (hot water shower)	
95	Kammer-Kw	unit stores van	m. LKW (o.)
100	Drehkran 3 – 5 ton	3 – 5-ton revolving crane on cc carrier	s. gl. LKW (4,5-ton)

Abbreviations and Definitions:

“Carrier”	indicates an open vehicle, covered by a canvas top.
“Truck”	indicates a cargo vehicle with an open payload area, covered by a canvas top.
“Van”	indicates a cargo vehicle with a fully or partially enclosed payload area (body).
“Prime-Mover”	indicates a vehicle for towing equipment, usually modified and adapted for that equipment.
“Sedan”	indicates a passenger vehicle (car) with a closed body.
“Cabrio”	indicates an open passenger vehicle (car) covered by a canvas top.
“cc”	indicates a vehicle with cross-country capability.

A	<i>Allrad</i> : all-wheel-drive version. (Makers identification).
S	<i>Steuerermässigt</i> : (taxed reduced) qualified for 33% motor vehicle tax reduction, introduced as incentive to increase demand for off-road capable trucks.
(o.)	<i>(ohne handelsüblich)</i> : commercial vehicle.
Kfz.	<i>Kraftfahrzeug</i> : commercially available chassis and drive train with military body.
Sd.Kfz.	<i>Sonderkraftfahrzeug</i> : specially military body and chassis.
le. / lei.	<i>leicht</i> : light
m.	<i>mittler</i> : medium
s.	<i>schwer</i> : heavy
LKW	<i>Lastkraftwagen</i> : load (cargo) motor vehicle (truck or van)
PKW	<i>Personenkraftwagen</i> : personnel (passenger) motor vehicle (car)
gl.	<i>geländegängig</i> : cross-country
Kw.	<i>Kraftwagen</i> : motor vehicle
kl.	<i>klein</i> : small/light
gr.	<i>gross</i> : large/heavy
gp.	<i>gepanzert</i> : armored
wg.	<i>wassergängig</i> : amphibious
schw.	<i>schwimmfähig</i> : amphibious (alternate)

GERMAN SPECIAL MILITARY VEHICLES

Sd.Kfz. No.	German Designation « German Abbreviation »	Description Main Armament [Ammunition carried]
2	Kleines Kettenrad « KK »	0.5-ton light halftrack n/a
2/1	Kleines Kettenrad (Feldfern-kabel) « KK (FFK) »	0.5-ton halftrack with telephone cable n/a
2/2	Kleines Kettenrad (schwere Feldfern-kabel) « KK (s. FFK) »	0.5-ton halftrack with heavy telephone cable n/a
3	Gleisketten-Lastkraftwagen 2-ton (Maultier) « 2-ton Maultier »	halftracked 2-ton truck n/a
3/4	Gleisketten-Lastkraftwagen 2-ton (Maultier) (Krankenwagen) « 2-ton Maultier (KrKw) »	halftracked 2-ton ambulance n/a
3/5	Gleisketten-Lastkraftwagen 4.5-ton (Maultier) « 4.5-ton Maultier »	halftracked 4.5-ton truck n/a
4	Gleisketten-Lastkraftwagen 3-ton (Maultier) gepanzert (Munitionskraftwagen) « gep. Maultier (muni) »	armored halftracked truck for ammunition transport [transports 20 150mm rockets]
4/1	15cm Panzerwerfer 43 « Pz.Werf. 43 »	armored halftracked truck with rocket launcher 150mm rocket launcher (10 tubes) [20]
6	mittlerer Zugkraftwagen 5-ton (Pionier-Ausführung) « m. Zgkw. 5t (Pion. Ausf.) »	5-ton halftrack (engineer version) n/a
6/1	mittlerer Zugkraftwagen 5-ton (Artillerie-Ausführung) « m. Zgkw. 5t (Artl. Ausf.) »	5-ton halftrack (artillery version) n/a
6/2	3,7cm Flak 36 auf Fahrgestell m. Zugkraftwagen 5-ton « 3,7cm Flak (Sfl) auf lei. Zgkw. 5 t »	self-propelled medium antiaircraft gun on 5-ton halftrack 37mm Flak 18 or 36 [?]
7	mittlerer Zugkraftwagen 8-ton « m. Zgkw. 8t »	8-ton halftrack n/a
7/1	2cm Flakvierling auf Fahrgestell mittlerer Zugkraftwagen 8-ton « 2cm Flakvierl. (Sf) auf Zgkw. 8t »	self-propelled light quad antiaircraft gun on 8-ton halftrack 20mm quad Flak38 L/112.5 [600]
7/2	3,7cm Flak 36 /Sfl) auf Fahrgestell mittlerer Zugkraftwagen 8-ton « 2cm Flakvierl. (Sf) auf Zgkw. 8t »	self-propelled antiaircraft gun on 8-ton halftrack 37mm Flak 36 L/98 [?]
7/6	mittlerer Zugkraftwagen 8-ton (Flakmess) « Zgkw. 8t Flak-Mess »	8-ton halftrack for antiaircraft calibration equipment n/a
8	schwerer Zugkraftwagen 12-ton « s. Zgkw. 12t »	12-ton halftrack n/a
8	8,8cm Flak (Sf) auf gepanzertem Zugkraftwagen 12-ton « 8,8cm Flak (Sf) auf gep. Zgkw. 12t »	self-propelled heavy antiaircraft gun on armored halftrack 88mm Flak L/56 [40]
9	schwerer Zugkraftwagen 18-ton « Zgkw. 18t »	18-ton halftrack n/a
9/1	schwerer Drehkranwagen (Hebekraft 6 ton) « s. Drehkran (6 t) »	18-ton halftrack with 6-ton revolving crane (manufactured by Bilstein) n/a
9/2	schwerer Drehkranwagen (Hebekraft 10 ton) « s. Drehkran (10 t) »	18-ton halftrack with 10-ton revolving crane (manufactured by Demag) n/a
10	leichter Zugkraftwagen 1-ton « lei. Zgkw. 1t »	1-ton halftrack n/a
10/1	leichter Gasspürwagen « lei. Zgkw. (Gas-Spür) »	1-ton halftrack, light gas detection vehicle with sprinkler n/a
10/2	leichter Entgiftungskraftwagen « lei. Zgkw. (Entg.) »	1-ton halftrack, light decontamination vehicle n/a
10/3	leichter Sprühkraftwagen « lei. Zgkw. (Sprüh) »	1-ton halftrack, light bulk decontamination vehicle n/a
10/4	2cm Flak (Sf) auf Fahrgestell leichter Zugkraftwagen 1-ton « 2cm Flak (Sf) auf lei. Zgkw. 1t »	self-propelled light antiaircraft gun on 1-ton halftrack 20mm Flak 30 L/112.5 [280]
10/5	2cm Flak (Sf) auf gepanzertem Fahrgestell leichter Zugkraftwagen 1-ton « 2cm Flak (Sf) auf gp. lei. Zgkw. 1t »	self-propelled light antiaircraft gun on armored 1-ton halftrack 20mm Flak 38 L/112.5 [280]
11	leichter Zugkraftwagen 3-ton « lei. Zgkw. 3t »	3-ton halftrack n/a
11/1	Nebelkraftwagen « m. Zgkw. (Nebel) »	3-ton halftrack for towing rocket launchers n/a [10,5cm Nbl.W. 35: 80 rockets; 15cm Nbl.W. 41: 36 rockets; 28/32cm Nebelwerfer 41: 12 rockets plus launching frames]
11/2	mittlerer Entgiftungskraftwagen « m. Zgkw. (Entg.) »	3-ton halftrack, medium decontamination vehicle n/a
11/3	mittlerer Sprühkraftwagen « m. Zgkw. (Sprüh) »	3-ton halftrack, medium chemical spraying vehicle (bulk decontamination) n/a

GERMAN SPECIAL MILITARY VEHICLES

Sd.Kfz. No.	---German Designation « German Abbreviation »	Description Main Armament [Ammunition carried]
11 /4	Nebelkraftwagen « m. Zgkw. (Nebel) »	3-ton halftrack for towing 15cm rocket launchers n/a [15cm Nbl.W. 41: 36 rockets; 21cm Nbl.W. 42: 10 rockets; 28/32cm Nebelwerfer 41: 4 rockets]
11 /5	Nebelkraftwagen « m. Zgkw. (Nebel) »	3-ton halftrack for towing 21cm rocket launchers n/a [15cm Nbl.W. 41: 36 rockets; 21cm Nbl.W. 42: 10 rockets]
35	Bergepanzer « Berge-Pz. »	armored recovery vehicle (T-34 or KV-I w/o turret) n/a
101	Panzerkampfwagen I « Pz. I »	light tank 2 MG 13 [1525 – 2250]
–	Panzerkampfwagen I, Ausf. F (n.A. verstärkt) « Pz. I, n.A. »	light tank, reinforced armor, Model F 2 MG 34 [2250]
–	4,7cm Pak(t)(Sf) auf Fahrgestell Panzerkampfwagen I « 4,7cm Pak(t) auf Pz-I; [also 4,7cm(t) (mot S)] »	self-propelled antitank gun on Pz-I chassis 47mm Pak(t) L/43.4 [86]
–	15cm sIG 33 auf Panzerkampfwagen I, Ausf. B « 15cm sIG33 auf Pz-I; [also 15cm sIG (mot S)] »	self-propelled heavy infantry gun on Pz-I chassis 150mm L/43.4 [?]
–	Pionier-Panzerwagen I « Pion-Pz. I »	Engineer vehicle (without turret) on Pz-I chassis n/a
111	Munitionsschlepper auf Fahrgestell Panzerkampfwagen I « Muni-Schlepper auf Pz-I »	armored ammunition carrier based on Pz-I chassis varied, depending upon ammunition type carried
121	Panzerkampfwagen II « Pz. II »	light tank 20mm KwK 30 L/55 [180]
122	Flamm-Panzer-II « Fl.Pz. II »	flame throwing tank on Pz-II basis [320 liters flame oil]
123	Panzerspähwagen II (Luchs 2cm) « lei. Pz-Späh. Wg. Luchs »	light, fully tracked recon tank on Pz-II basis 20mm KwK 38 L/55 [330]
123	Panzerspähwagen II (Luchs 5cm) « lei. Pz-Späh. Wg. Luchs »	light, fully tracked recon tank on Pz-II basis 50mm KwK L/60 [33]
124	lei. FH 18/2 Selbstfahrlafette auf Pz-II (Wespe) « Wespe »	self-propelled light field howitzer on Pz-II basis 105mm le FH 18/2 [32]
–	Munitions-Selbstfahrlafette auf Pz-II (Wespe) « Muni. Wespe »	armored ammunition carrier for Wespe on same chassis [transports 90 light field howitzer rounds]
–	Geschützwagen II für 15cm sIG « 15cm sIG (sfl) »	self-propelled heavy infantry gun 150mm L/43.4 [30]
–	Pionier-Panzerwagen II « Pion-Pz. II »	Engineer vehicle (without turret) on Pz-II chassis n/a
131	Panzer-Selbstfahrlafette für 7,5cm Pak 40/2 auf Fahrgestell Panzerkampfwagen II « Marder II; [also 7,5cm Pak 40 (Sf) auf Pz-II; also Pz Sf 2] »	self-propelled antitank gun on Pz-II chassis 75mm Pak L/43 [37]
132	Panzer-Selbstfahrlafette für 7,62cm Pak 36(r) auf Fahrgestell Panzerkampfwagen II « Marder II; [also 7,62cm Pak 36(r)(Sf) auf Pz-II; also Pz Sf 1] »	self-propelled antitank gun on Pz-II chassis (Models D and E) 76.2mm Pak(r) L/51.5 [30]
135	75mm Pak auf Lorraine-Schlepper (Marder I) « Marder I »	self-propelled heavy antitank gun on Lorraine basis 75mm s FH Pak 40/1 [?]
135 /1	s. FH 13/1 Selbstfahrlafette auf Lorraine-Schlepper « s.FH (sfl) auf Lorraine »	self-propelled heavy field howitzer on Lorraine basis 150mm s FH 13/1 [8]
–	Panzerkampfwagen 35 (t) « Pz-35(t) »	Czech medium tank (designation changed from LTM 35 on 16.01.40) 37mm A33 L/42 [72]
–	Panzerbefehlwagen 35 (t) « Pz-Bef-Wg 35(t) »	Czech medium command tank 37mm A33 L/42 [?]
–	Mörserwagen 35 (t) « Mörs.Wg. 35(t) »	tracked prime mover for heavy mortar on Czech medium tank basis n/a
–	Zugkraftwagen 35 (t) « Zgkw. 35(t) »	tracked prime mover based on Czech medium tank n/a
–	Panzerkampfwagen 38(t), Ausführung A – G « Pz-38(t) »	Czech medium tank (designation changed from LTM 38 on 16.01.40) 37mm A7 L/42 [90]
–	Panzerbefehlwagen 38(t) « Pz-Bef-Wg 38(t) »	Czech medium command tank 37mm A7 L/42 [?]
138	Panzerjäger 38(t), Ausf. H für 7,5cm Pak « Marder III »	self-propelled antitank gun on Pz-38(t) chassis 75mm Pak 40/3 L/48 [38]
138	Panzerjäger 38(t), Ausf. M für 7,5cm Pak « Marder III »	self-propelled antitank gun on Pz-38(t) chassis 75mm Pak 40/3 L/48 [27]
138	Munitionsfahrzeug für 15cm s.IG selbstfahrlafette « Muni. Fahrzeug für 15cm s.IG Sfl »	armored ammunition carrier for Bison on same chassis [transports 40 infantry gun rounds]

GERMAN SPECIAL MILITARY VEHICLES

Sd.Kfz. No.	German Designation « German Abbreviation »	Description Main Armament [Ammunition carried]
138/1	s.IG auf Selbstfahrlafette 38(t) « s.IG (sfl) <i>Grille</i> »	self-propelled heavy infantry gun on Pz-38(t) chassis 150 sIG 33/1 L/11 [15]
138/2	Jagdpanzer 38 « <i>Hetzer</i> »	light tank destroyer on Pz-38(t) basis 75mm Pak 39 L/48 [41]
–	Flammpanzer 38 « Flamm-Pz 38 »	flame tank based on <i>Hetzer</i> hull [700 liters flame oil]
–	Bergepanzer 38 « Berge-Pz 38 »	recovery tank based on <i>Hetzer</i> hull n/a
–	15cm schwerer Infanteriegeschütz 33/2 auf Jagdpanzer 38 « 15cm sIG 33/2 auf PzJg 38(t) »	self-propelled heavy infantry gun based on <i>Hetzer</i> hull 150mm sIG 33/2 [?]
139	Panzerjäger 38(t) für 7,62cm Pak 36(r) « <i>Marder III</i> »	self-propelled antitank gun on Pz-38(t) chassis 76.2mm Pak(r) L/51.5 [30]
140	Flakpanzer 38 « Flak-Pz-38 »	Self-propelled anti-aircraft gun based on Czech Pz-38(t) 20mm Flak 38 [540]
140/1	Aufklärungspanzer 38(t) (2cm) « Aufkl-Pz-38(t) (2cm) »	Czech reconnaissance tank based on Pz-38(t) 20mm KwK 38 [108]
140/1	Aufklärungspanzer 38(t) (7,5cm) « Aufkl-Pz-38(t) (7,5cm) »	Czech reconnaissance support tank based on Pz-38(t) 75mm KwK 37 L/24 [?]
141	Panzerkampfwagen III, Ausführung A – G « Pz. III (3,7cm) »	medium tank, Models A – G 37mm KwK 35/36 L/45 [120]
141	Panzerkampfwagen III, Ausführung H – J « Pz. III (5cm); [also Pz-III (kz)] »	medium tank, Models H – J 50mm KwK L/42 [99]
141/1	Panzerkampfwagen III, Ausführung J – L « Pz. III (5cm); [also Pz-III (lg)] »	medium tank, Model J – L 50mm KwK L/60 [84 – 78]
141/2	Panzerkampfwagen III, Ausf. M – N « Pz. III (7,5cm) »	medium tank, Models M – N 75mm KwK 37 L/24 [84 – 64]
141/3	Flammpanzer III « Flamm-Pz. III »	medium flame-throwing tank [1020 liters flame oil]; MG [3750]
–	SturmInfanteriegeschütz 33B « St. Inf. Gesch. 33 »	self-propelled, armored heavy infantry gun on Sturmgeschütz basis 150mm Stu IG L/11 [30]
142	7,5cm Sturmgeschütz 40, Ausführung A – D « Sturmgeschütz III [also: Stu. Gesch. III] »	assault gun, Model A – D 75mm StuK 37 L/24 [44]
142	7,5cm Sturmgeschütz 40, Ausführung E « Sturmgeschütz III [also: Stu. Gesch. III] »	assault gun, Model E 75mm StuK 37 L/24 [50]
142	7,5cm Sturmgeschütz 40, Ausführung F « Sturmgeschütz III [also: Stu. Gesch. III] »	assault gun, Model F 75mm StuK 37 L/24 [44]
142/1	7,5cm Sturmgeschütz 40, Ausführung F8 – G « Sturmgeschütz III [also: Stu. Gesch. III] »	assault gun, Model F8 – G 75mm StuK40 L/43 [54]
142/2	7,5cm Sturmhaubitze, Ausführung F – G « Sturmhaubitze III [also: Stu. Haub. III] »	assault howitzer, Model F – G 105mm StuH 42 L/28 [36]
143	Panzer-Beobachtungswagen III « Pz. Beob. Pz. III »	armored artillery observation tank MG [2100]
161	Panzerkampfwagen IV, Ausführung A – F ₁ « Pz. IV [also: Pz-IV(kz)] »	medium tank, Models A – F ₁ 75mm KwK 37 L/24 [80]
161/1	Panzerkampfwagen IV, Ausführung F ₂ – G « Pz. IV [also: Pz-IV(lg)] »	medium tank, Models F ₂ – G 75mm KwK 40 L/43 [87]
161/2	Panzerkampfwagen IV, Ausführung H – J « Pz. IV [also: Pz-IV(lg)] »	medium tank, Models H – J 75mm KwK 40 L/48 [87]
161/3	Flakpanzer-IV « Flak-Pz 3,7cm [<i>Ostwind</i>] »	anti-aircraft tank 37mm Flak 43 L/98 [400]
161/4	Flakpanzer-IV « Flak-Pz 2cm-Vierling [<i>Wirbelwind</i>] »	anti-aircraft tank 20mm quad Flak 38 [1000]
–	Panzer-Flak Sfl IV « Pz-Flak IV [<i>Möbelwagen</i>] »	anti-aircraft tank 37mm Flak 43 L/98 [416]
162	7,5cm Pak 39 auf Fahrgestell Panzerkampfwagen IV « Jagdpanzer IV »	self-propelled heavy antitank gun on Pz-IV basis 75mm Pak 39 L/48 [79]
162/1	7,5cm StuK 42 auf Fahrgestell Panzerkampfwagen IV, Ausführung A « Panzer-IV/70 (A) »	tank destroyer on Pz-IV basis 75mm StuK 42 L/70 [55]
162/1	7,5cm StuK 42 auf Fahrgestell Panzerkampfwagen IV, Ausführung V « Panzer-IV/70 (V) »	tank destroyer on Pz-IV basis 75mm StuK 42 L/70 [55]

GERMAN SPECIAL MILITARY VEHICLES

Sd.Kfz. No.	German Designation « German Abbreviation »	Description Main Armament [Ammunition carried]
163	7,5cm Sturmgeschütz IV « Sturmgeschütz IV [also: StuG IV] »	assault gun based on Pz-IV 75mm StuK40 L/48 [63]
164	8,8cm Pak 43/1 auf Fahrgestell Panzerkampfwagen III/IV (Hornisse) « Hornisse; [as of 1944: Nashorn] »	self-propelled heavy antitank gun on mixed Pz-III/IV basis 88mm Pak 43/1 L/71 [40]
165	s. Panzerhaubitze 18/1 auf Fahrgestell III/IV (Hummel) « Hummel »	self-propelled heavy field howitzer on mixed Pz-III/IV basis 150mm sFH 18/1 [18]
–	Munitionsfahrzeug für 15cm s. IG selbstfahrlafette « Muni. Fahrzeug für 15cm s.IG Sfl »	armored ammunition carrier for Hummel on same chassis [transports 60 heavy field howitzer rounds]
165 /1	leichte Feldhaubitze (Sfl)/Geschützwagen IVb « leFH (sfl) »	self-propelled light field howitzer on Pz-IV basis 105mm leFH 18/1 [60]
166	s. IG auf Panzerkampfwagen-IV Fahrgestell (Sturmpanzer) « Stu-Pz IV [aka Brummbär] »	armored, self-propelled heavy infantry gun on Pz-IV chassis 150mm StuH 43 L/12 [38]
–	10,5cm Kanone 18 auf Panzer-Selbstfahrlafette IVa « 10,5cm K18 auf Pz-Sfl IVa »	self-propelled gun on Pz-IV chassis 105mm StuK 18/1 L/52 [25]
171	Panzerkampfwagen V (Panther), Ausführung D, A « Panther »	medium tank, Models D and A 75mm KwK 42 L/70 [79]
171	Panzerkampfwagen V (Panther), Ausführung G « Panther »	medium tank, Models G 75mm KwK 42 L/70 [82]
173	Jagdpanzer V « Jagdpanther »	tank destroyer on Panther basis 88mm Pak 43/3 L/71 [57]
179	Bergepanther « Berge-Pz-V »	armored recovery vehicle on Panther basis 20mm KwK 38 [?]
181	Panzerkampfwagen VI (Tiger I), Ausführung E « Tiger I »	heavy tank, Model E 88mm KwK 36 L/56 [92]
–	Panzer-Mörser 38cm auf VI (Tiger) « Sturmiger »	self-propelled heavy rocket launcher on Pz-VI(I) chassis 380mm rocket launcher [12]
182	Panzerkampfwagen VI (Tiger II), Ausführung B « Tiger II [aka Königstiger] »	heavy tank 88mm KwK 43 L/71 [72–84]
184	Panzerjäger Tiger (P) für 8,8cm Pak 43 (Ferdinand) « Ferdinand; [later Elefant] »	self-propelled, heavy antitank gun on prototype Pz-VI chassis 88mm StuK 43/1 L/71 [55]
186	schwere Panzerjäger, Ausführung B « Jagdtiger »	heavy tank destroyer 128mm Pak 44 L/55 [40]
221	leichter Panzerspähwagen (MG) « le. Pz-Späh. Wg. (MG) »	light armored car (4x4) MG [1020]
221	leichter Panzerspähwagen (schwere Panzerbüchse 41) « le. Pz-Späh. Wg. (sPzBü 41) »	light armored car (4x4) 28mm sPzBü 41 [180]
222	leichter Panzerspähwagen (2cm) « le. Pz-Späh. Wg. (2cm) »	light armored car (4x4) 20mm KwK 38 L/55 [180]
223	leichter Panzerspähwagen (Funk) « le. Pz-Späh. Wg. (Fu) »	light armored radio car (4x4) MG [1050]
231	schwerer Panzerspähwagen (2cm)(6-Rad) « s. Pz-Späh. Wg. (2cm) »	heavy armored car (6x4) 20mm KwK 30 L/55 [200]
232	schwerer Panzerspähwagen (Funk)(6-Rad) « s. Pz-Späh. Wg. (Fu) »	heavy armored radio car (6x4) 20mm KwK 30 L/55 [200]
231	schwerer Panzerspähwagen (2cm)(8-Rad) « s. Pz-Späh. Wg. (2cm) 8-Rad »	heavy armored car (8x8) 20mm KwK 30 L/55 [180]
232	schwerer Panzerspähwagen (Funk)(8-Rad) « s. Pz-Späh. Wg. (Fu) 8-Rad »	heavy armored radio car (8x8) 20mm KwK 30 L/55 [180]
233	schwerer Panzerspähwagen (7,5cm)(8-Rad) « s. Pz-Späh. Wg. (7,5cm) 8-Rad »	heavy armored radio car (8x8) 75mm StuK 37 L/24 [32]
234 /1	schwerer Panzerspähwagen (2cm) « Pz-Späh. Wg. (2cm) »	heavy armored car (8x8) 20mm KwK 30 L/55 [250]
234 /2	schwerer Panzerspähwagen (5cm) « Pz-Späh. Wg. (2cm) [aka Puma] »	heavy armored car (8x8) 50mm KwK 39/1 L/60 [55]
234 /3	schwerer Panzerspähwagen (7,5cm) « Pz-Späh. Wg. (7,5cm) »	heavy armored car (8x8) 75mm K-51 L/24 [50]
234 /4	schwerer Panzerspähwagen (7,5cm Pak) « Pz-Späh. Wg. (7,5cm Pak) »	heavy armored car (8x8) 75mm Pak 40 [12]
247	schwerer geländegängiger gepanzerter Personenkraftwagen (4-Rad) « s. gl. gep. PKW »	heavy armored staff car (4x4) n/a
247	schwerer geländegängiger gepanzerter Personenkraftwagen (6-Rad) « s. gl. gep. PKW »	heavy armored staff car (6x4) n/a

GERMAN SPECIAL MILITARY VEHICLES

Sd.Kfz. No.	German Designation « German Abbreviation »	Description Main Armament [Ammunition carried]
250 /1	leichter Schützenpanzerwagen « le. SPW »	light armored halftrack, personnel carrier MG [2010]
250 /1	leichter Schützenpanzerwagen « le. SPW »	light armored halftrack, heavy machine gun section carrier MG [2010]
250 /2	leichter Fernsprechpanzerwagen « le. Fe. Pzgw. »	light armored halftrack, telephone & wire carrier MG [1100]
250 /3	leichter Funkpanzerwagen « le. Fu. Pzgw. »	light armored halftrack, radio carrier MG [1100]
250 /4	leichter Beobachtungs-Panzerwagen « le. Beob. Pzgw. »	light armored halftrack, observation vehicle MG [1100]
250 /5	leichter Beobachtungspanzerwagen « le. Beob. Pzgw. »	light armored halftrack, observation vehicle MG [2010]
250 /5	leichter Aufklärungspanzerwagen « le. Beob. Pzgw. »	light armored halftrack, reconnaissance vehicle MG [2010]
250 /6	leichter Munitionspanzerwagen « le. Muni. Pzgw. »	light armored halftrack, ammunition carrier MG [1100] [transports 70 L/24 or 60 L/43 rounds]
250 /7(I)	leichter Schützenpanzerwagen (schwere Granatwerfer) « le. SPW (Gr Wfr) »	light armored halftrack, mortar carrier 81mm mortar [42]
250 /7(II)	leichter Schützenpanzerwagen (Munitionsfahrzeug) « le. SPW (Muni) »	light armored halftrack, 81mm mortar ammunition carrier MG [2010] [transports 66 mortar rounds]
250 /8	leichter Kanonenpanzerwagen (7,5cm) « le. SPW (2cm) »	light armored halftrack, support vehicle 75mm KwK 51 L/24 [20]
250 /9	leichter Schützenpanzerwagen (2cm) « le. SPW (2cm) »	light armored halftrack, reconnaissance vehicle 20mm KwK 38 [100]
250 /10	leichter Schützenpanzerwagen (3,7cm Pak) « le. SPW (3,7cm) »	light armored halftrack, Platoon Leader vehicle 37mm Pak L/45 [216]
250 /11	leichter Schützenpanzerwagen (schwere Panzerbüchse 41) « le. SPW (sPzBü 41) »	light armored halftrack, Platoon Leader vehicle 28mm PzBü 41 [168]
250 /11	leichter Messtrupp-Auswertungs-Panzerwagen « le. Mess-Trupp-Pzgw. »	light armored halftrack, Calibration Section vehicle MG [1040]
251 /1	mittlerer Schützenpanzerwagen « m. SPW »	medium armored halftrack, personnel carrier MG [2010]
251 /2	mittlerer Schützenpanzerwagen (Granatwerfer) « m. SPW (Gr Wfr) »	medium armored halftrack, mortar carrier 81mm mortar [66]
251 /3	mittlerer Funkpanzerwagen « m. Fu. Pzgw. »	medium armored halftrack, radio carrier MG [2010]
251 /4	mittlerer Schützenpanzerwagen (Infanteriegeschütz) « m. SPW (IG) »	medium armored halftrack, light IG prime-mover MG [1100] [transports 120 rounds of 75mm ammo]
251 /5	mittlerer Pionierpanzerwagen « m. Pion. Pzgw. »	medium armored halftrack, engineer vehicle MG [4800]
251 /6	mittlerer Kommandopanzerwagen « m. Pion. Pzgw. »	medium armored halftrack, command vehicle MG [1100]
251 /7	mittlerer Pionierpanzerwagen « m. Pion. Pzgw. »	medium armored halftrack, engineer vehicle MG [4800]
251 /8	mittlerer Krankenpanzerwagen « m. Kranken-Pzgw. »	medium armored halftrack, ambulance n/a
251 /9	mittlerer Schützenpanzerwagen (7,5cm) « m. SPW (7,5cm) »	medium armored halftrack, self-propelled light gun 75mm KwK 37 L/24 [32]
251 /10	mittlerer Schützenpanzerwagen (3,7cm Pak) « m. SPW (3,7cm) »	medium armored halftrack, Platoon Leader vehicle 37mm Pak L/45 [168]
251 /10	mittlerer Schützenpanzerwagen (sPzBü) « m. SPW (sPzBü) »	medium armored halftrack, Platoon Leader vehicle 28mm sPzBü 41 L/28/20 [168]
251 /11	mittlerer Fernsprech-Panzerwagen « m. SPW (Fe) »	medium armored halftrack, telephone cable-laying vehicle MG [1100]
251 /12	mittlerer Meßtrupp- und Gerät-Panzerwagen « m. Meßtrupp Pzgw. »	medium armored halftrack, Calibration Section equipment vehicle MG [1100]
251 /13	mittlerer Schallaufnahme-Panzerwagen « m. Schall-Aufnahme-Pzgw. »	medium armored halftrack, sound recording vehicle MG [1100]
251 /14	mittlerer Schallauswerte-Panzerwagen « m. Schall-Auswerte-Pzgw. »	medium armored halftrack, sound ranging vehicle MG [1100]

GERMAN SPECIAL MILITARY VEHICLES

Sd.Kfz. No.	German Designation « German Abbreviation »	Description Main Armament [Ammunition carried]
251 /15	mittlerer Lichtauswerte-Panzerwagen « m. Licht-Auswerte-Pzwg. »	medium armored halftrack, sound flash ranging vehicle MG [1100]
251 /16	mittlerer Flamm-Panzerwagen « m. SPW (Flamm) »	medium armored halftrack, with 2 pivoted flame throwers 80 bursts of 2 – 3 seconds (700 liters flame oil); MG [2100]
251 /17	mittlerer Flak-Panzerwagen « m. SPW (2cm) »	medium armored halftrack, self-propelled light anti-aircraft gun 20mm Flak 38 [600]
251 /18	mittlerer Beobachtungs-Panzerwagen « m. Beob.-Pzwg. »	medium armored halftrack, observation vehicle MG [1100]
251 /19	mittlerer Fernsprech-Betriebs-Panzerwagen « m. Fs.Betr.-Pzwg. »	medium armored halftrack, telephone operations vehicle MG [1100]
251 /20(I)	mittlerer Panzerwagen (Uhu) « m. Pzwg. (Uhu) »	medium armored halftrack, infrared projector vehicle MG [1100]
251 /20(II)	mittlerer Panzerwagen (Falke) « m. Pzwg. (Falke) »	medium armored halftrack, infrared viewer vehicle MG [1100]
251 /21	mittlerer Panzerwagen (MG 151/15 Drilling) « m. SPW (MG 1,5cm) »	medium armored halftrack, self-propelled light anti-aircraft gun 15mm triple MG 151/15 [3000]
251 /21	mittlerer Panzerwagen (MG 151/20 Drilling) « m. SPW (MG 2cm) »	medium armored halftrack, self-propelled light anti-aircraft gun 20mm triple MG 151/20 [3000]
251 /22	mittlerer Panzerwagen (7,5cm Pak) « m. SPW (7,5cm Pak) »	medium armored halftrack, self-propelled anti-tank gun 75mm Pak 40 L/48 [22]
251 /23	mittlerer Panzerwagen (2cm Flak) « m. SPW (2cm Flak) »	medium armored halftrack, self-propelled light anti-aircraft gun 20mm KwK 38 L/55 [180]
252	leichter gepanzerter Munitionswagen « le. gep. Muni-Wg. »	light armored halftrack, ammunition carrier MG [1020]
253	leichter gepanzerter Beobachtungswagen « le. gep. Beob. Wg. »	light armored halftrack, observation vehicle MG [1100]
254	mittlerer gepanzerter Beobachtungswagen « m. gep. Beob. Wg. »	medium armored wheeled/tracked observation vehicle MG [1100]
260	kleiner Panzerfunkwagen « kl. Pz. Fu. Wg. »	light armored radio car (4x4) n/a
261	kleiner Panzerfunkwagen « kl. Pz. Fu. Wg. »	light armored radio car (4x4) n/a
263	schwerer Panzerfunkwagen « s. Pz. Fu. Wg. »	heavy armored radio car (6x4) MG [1020]
266	Panzerbefehlswagen « gr. Pz-Bef-Wg. »	command tank based on Pz-III, Pz-IV, Pz-V, or Pz-VI MG [1500]
267	Panzerbefehlswagen « gr. Pz-Bef-Wg. »	command tank based on Pz-III, Pz-IV, Pz-V, or Pz-VI MG [1500]
268	Panzerbefehlswagen « gr. Pz-Bef-Wg. »	command tank based on Pz-III, Pz-IV, Pz-V, or Pz-VI MG [1500]
300	Minenräumwagen B-I & B-II « Minenräum-Wg. »	tracked mineclearing vehicle, Model B-I & B-II n/a
301	schwere Ladungsträger B-IV « B-IV »	tracked, remote-controlled demolition vehicle, Model B-IV n/a
302	Leichte Ladungsträger Goliath, Ausf. A « Goliath »	tracked, remote-controlled demolition vehicle, Model A (electric) n/a
303	Leichte Ladungsträger Goliath, Auf. B « Goliath »	tracked, remote-controlled demolition vehicle, Model B (gasoline) n/a
304	mittlere Ladungsträger « Springer »	tracked, remote-controlled demolition vehicle n/a

Notes:

For the sake of completeness, this list includes the unnumbered vehicles belonging to the same family of vehicles.

GERMAN SPECIAL MILITARY TRAILERS AND MILITARY TRAILERS

German Trailers

Besides the numbered trailers listed below, there were also trailers without numbers. These were identified by load factor, number of axles, open or covered, and/or purpose. Furthermore, upon mobilization, the German military requisitioned trailers from the civilian sector. These trailers were strictly for use by road-bound units, and only found in rear-echelon units where they provided a valuable increase in transportation capacity. There were even trailers built specifically for towing horse drawn equipment with motor vehicles.

A few military horse-drawn vehicles (wagons and carts) were modified for towing by motor vehicles by the addition of wheel and parking brakes, rubber-rimmed or even pneumatic tires, rear lights, and towing arrangements.

Some horse-drawn wagon and carts were issued with towing bars allowing them to be towed by motor vehicles.

It was not unusual, specially in the non-motorized units, that unmodified horse-drawn vehicles be towed by motor vehicles. Naturally at comparatively low speeds.

Although many combat units had trailers for guns, ammunition, components of heavy guns, generators, bridging equipment, etc., convoy speed of all vehicles was reduced when towing trailer, and maneuverability was hampered off-road. However, the expense of motor vehicles made the use of trailers an attractive alternative.

<i>Sd.Anh.-Sonder Anhänger</i>	<i>Special Trailers with numbers</i>
Sd.Anh. 1 (1 Achsig) für kleines Kettenrad	trailer (1 axle) for Kettenrad
Sd.Anh. 1/1 (1 Achsig) für kleines Kettenrad	trailer (1 axle) for Kettenrad
Sd.Anh. 1/2 (1 Achsig) für kleines Kettenrad für schweres Feldkabel	trailer (1 axle) for Kettenrad, with heavy telephone field cable.
Sd.Anh. 3 (1 Achsig) für leichte Lasten	trailer (1 axle) for transporting light artillery guns (7,5cm leFK 16 and 10,5cm leFH 16)
Sd.Anh. 4 (1 Achsig) für mittlere und schwere Lasten	trailer (1 axle) for transporting medium and heavy artillery guns (15cm sFH 13)
Sd.Anh. 5 (1 Achsig) für Artilleriemunition	trailer (1 axle) for artillery ammunition
Sd.Anh. 7 (1 Achsig) für Munition (Nbl. Wfr.)	trailer (1 axle) for Nebelwerfer ammunition
Sd.Anh. 8 (1 Achsig) für Veterinärgerät	trailer (1 axle) for veterinary equipment
Sd.Anh. 11 (1 Achsig) für Entseuchung mit Brausevorrichtung	trailer (1 axle) for decontamination with showers
Sd.Anh. 13 (1 Achsig) für M-Boot (100 PS MB 41)	trailer (1 axle) for motorboat (100 HP Type MB 41)
Sd.Anh. 14 (1 Achsig) für Abschleppzwecke	trailer (1 axle) for motor vehicle towing and recovery
Sd.Anh. 15 (1 Achsig) für Fährseil	trailer (1 axle) for winch
Sd.Anh. 20 (1 Achsig) für Erdkabel	trailer (1 axle) for underground telephone cable
Sd.Anh. 21 (2 Achsig) für Fernsprechbau	trailer (1 axle) for telephone construction
Sd.Anh. 22 (1 Achsig) Azetylen-Erzeugeranhängen	trailer (1 axle) for generator for Acetylene gas
Sd.Anh. 23 (1 Achsig) für Sammlerladegerät D	trailer (1 axle) for Generator Type D for recharging batteries
Sd.Anh. 23/1 (1 Achsig) für Maschinensatz 220/65V; 4,5/1,3 Kw	trailer (1 axle) for Generator 220/65 Volt, 4.5/1.3 Kw
Sd.Anh. 24 (1 Achsig) für Maschinensatz I	trailer (1 axle) for Generator Type I
Sd.Anh. 24 (1 Achsig) für Maschinensatz A (Drehstrom 15k VA)	trailer (1 axle) for Generator Type A for 15k AC
Sd.Anh. 25 (1 Achsig) für Feldfernkabel	trailer (1 axle) for heavy telephone field cable
Sd.Anh. 25/1 (1 Achsig) für Maschinensatz F	trailer (1 axle) for Generator Type F
Sd.Anh. 25/2 (1 Achsig) für Nachrichtengerät	trailer (1 axle) for signal equipment
Sd.Anh. 25/3 (1 Achsig) Beleuchtungsanhänger N	trailer (1 axle) for Lighting Equipment Type N
Sd.Anh. 25/4 (1 Achsig) Nachschubanhänger	trailer (1 axle) for supply
Sd.Anh. 25/3 (1 Achsig) Beleuchtungsanhänger N	trailer (1 axle) for lighting equipment
Sd.Anh. 26 (1 Achsig) für Führungsfernkabel	trailer (1 axle) for command telephone heavy cable
Sd.Anh. 28 (1 Achsig) für Peilanhänger (für Peiltrupp (LMW)	trailer (1 axle) for direction finder of a Direction Finding Section
Sd.Anh. 29 (1 Achsig) für für gepanzerten Munitionsschlepper	trailer (1 axle) for ammunition (for armored ammunition carrier)
Sd.Anh. 30 (1 Achsig) Wassertankanhänger	trailer (1 axle) for water tank
Sd.Anh. 31 (1 Achsig) für Munition Type A	trailer (1 axle) for ammunition Type A
Sd.Anh. 31/1 (1 Achsig) für Munition (7,5cm StuK 40)	trailer (1 axle) for ammunition for 7.5cm Assault Gun Model 40
Sd.Anh. 32 (1 Achsig) für Munition (3,7cm Pak)	trailer (1 axle) for ammunition for 3,7cm Antitank Gun
Sd.Anh. 32/1 (1 Achsig) für Munition (7,5cm)	trailer (1 axle) for ammunition for 7,5cm
Sd.Anh. 32/2 (1 Achsig) für Munition (s. Pz Bü 41)	trailer (1 axle) for ammunition for heavy antitank rifle Model 41
Sd.Anh. 32/3 (1 Achsig) für s. Pz Bü 41 auf leichte Feldlafette	trailer (1 axle) for heavy antitank rifle Model 41 on light field carriage
Sd.Anh. 33 (1 Achsig) für Nebelwerfermunition	trailer (1 axle) for ammunition (rocket launcher)
Sd.Anh. 34 (1 Achsig) für Entgiftungsanhänger	trailer (1 axle) for decontamination
Sd.Anh. 35 (1 Achsig) für Teigknetanhänger	trailer (1 axle) for dough mixer
Sd.Anh. 36 (1 Achsig) für leichten Ladungsschlepper	trailer (1 axle) for remote control vehicle (Goliath)
Sd.Anh. 40 (1 Achsig) Panzerbergeanker als Anhänger	trailer (1 axle) for tank recovery anchor
Sd.Anh. 46 (1 Achsig) schmalspurig	trailer (1 axle) with narrow wheel spacing
Sd.Anh. 51 (1 Achsig) Beleuchtungsanhänger (Vermessungstrupp (mot)	trailer (1 axle) for electricity generator in enclosed body for Calibration Detachment
Sd.Anh. 51 (1 Achsig) für 2cm Geschütz 30 mit Munition- und Zubehörkasten	trailer (1 axle) for 2cm antiaircraft gun Model 30 with ammo and equipment boxes
Sd.Anh. 51 (1 Achsig) für Scheinwerfer 60cm mit Zubehörkasten	trailer (1 axle) for 60cm antiaircraft searchlight with equipment boxes
Sd.Anh. 51 (1 Achsig) für 2cm Flak 38 mit Munition- und Zubehörkasten	trailer (1 axle) for 20mm antiaircraft gun Model 38 with ammo and equipment boxes
Sd.Anh. 52 (1 Achsig) für 2cm Flak Vierling 38/1 mit Munition- und Zubehörkasten	trailer (1 axle) for 2cm quad antiaircraft gun Model 38/1 with ammo and equipment boxes
Sd.Anh. 52 (1 Achsig) für 3,7cm Flak 36/37 mit Munition- und Zubehörkasten	trailer (1 axle) for 3.7cm antiaircraft gun Model 36/37 with ammo and equipment boxes
Sd.Anh. 52 (1 Achsig) für Kommando-Gerät 40	trailer (1 axle) for antiaircraft fire direction computer Model 40
Sd.Anh. 53 (1 Achsig) für Kommando-Hilfsgerät 35	trailer (1 axle) for antiaircraft auxiliary fire direction computer Model 35
Sd.Anh. 54 (1 Achsig) für Kinotheodolit für Flakmess-Auswerte-Zug	trailer (1 axle) for antiaircraft optical tracking computer for Calibration Evaluation Platoon
Sd.Anh. 55 (1 Achsig) für V ^o -Messgerät Flak	trailer (1 axle) for antiaircraft muzzle velocity calibration equipment
Sd.Anh. 56 (1 Achsig) für 2cm Flak mit Munition- und Zubehörkasten	trailer (1 axle) for 2cm quad antiaircraft gun with ammo and equipment boxes
Sd.Anh. 56 (1 Achsig) für 2cm Flakvierling 38/1 mit Munition- und Zubehörkasten	trailer (1 axle) for 2cm quad antiaircraft gun Model 38/1 with ammo and equipment boxes
Sd.Anh. 57 (1 Achsig) für 3,7cm Flak mit Munition- und Zubehörkasten	trailer (1 axle) for 3.7cm antiaircraft gun with ammo and equipment boxes
Sd.Anh. 58 (1 Achsig) für 3,7cm Flak 43 mit Munition- und Zubehörkasten	trailer (1 axle) for 3.7cm antiaircraft gun Model 43 with ammo and equipment boxes
Sd.Anh. 58 (1 Achsig) für 3,7cm Flak 43/1 mit Munition- und Zubehörkasten	trailer (1 axle) for 3.7cm antiaircraft gun Model 43/1 with ammo and equipment boxes
Sd.Anh. 101 (2 Achsig) für Flakhorchgerät	trailer (2 axle) for antiaircraft sound tracking equipment
Sd.Anh. 101 (2 Achsig) für mittleren Flak-Maschinensatz	trailer (2 axle) for antiaircraft generator for sound tracking equipment
Sd.Anh. 102 (2 Achsig) für Flak-Scheinwerfer 110cm	trailer (2 axle) for antiaircraft searchlight (110cm)
Sd.Anh. 102 (2 Achsig) für Flak-Maschinensatz	trailer (2 axle) for antiaircraft generator for searchlight (110cm)
Sd.Anh. 103 (2 Achsig) für mittlere und schwere Lasten	trailer (2 axle) for medium and heavy cargo
Sd.Anh. 104 (2 Achsig) für 150cm Flak-Scheinwerfer	trailer (2 axle) for 150cm antiaircraft searchlight
Sd.Anh. 104 (2 Achsig) für Maschinensatz 24 Kw für 150cm Flak-Scheinwerfer	trailer (2 axle) for generator Model 24Kw for 150cm antiaircraft searchlight
Sd.Anh. 104 (2 Achsig) für Sperrballonwinde	trailer (2 axle) for winch for antiaircraft barrage ballon
Sd.Anh. 104 (2 Achsig) für Funkmessgerät 39 TD	trailer (2 axle) for antiaircraft radar Model 39TD
Sd.Anh. 104 (2 Achsig) für 3,7cm Flak 18	trailer (2 axle) for 3.7cm antiaircraft gun Model 18
Sd.Anh. 104 (2 Achsig) für Kommandogerät 36	trailer (2 axle) for antiaircraft fire direction computer Model 36
Sd.Anh. 104 (2 Achsig) für Richtung-Richtungshörer (RRH)	trailer (2 axle) for antiaircraft sound tracking equipment
Sd.Anh. 105 (2 Achsig) Backanhänger	trailer (2 axle) for baking oven
Sd.Anh. 106 (2 Achsig) Backanhänger	trailer (2 axle) for baking oven
Sd.Anh. 107 (2 Achsig) Grosskühlbehälteranhänger	trailer (2 axle) for refrigeration
Sd.Anh. 108 (2 Achsig) für S-Boot (Pionier-Strumboot 39)	trailer (2 axle) for three assault boats (Engineer Assault Boat Model 39)

GERMAN SPECIAL MILITARY TRAILERS AND MILITARY TRAILERS

Sd.Anh. 109	(2 Achsig) leichter Vermessungsanhänger	trailer (2 axle) for light calibration equipment
Sd.Anh. 111	(2 Achsig) schwerer Vermessungsanhänger	trailer (2 axle) for heavy calibration equipment
Sd.Anh. 113	(3 Achsig) für Langerät (8 ton)	trailer (3 axle) for cargo, long (8ton)
Sd.Anh. 115	Tiefhladeanhänger für PzKfpWg 10-12 ton	trailer (2 axle) low boy (also: low bed) for armored vehicles (10 – 12 ton)
Sd.Anh. 116	Tiefhladeanhänger für PzKfpWg 22 ton	trailer (4 axle) low boy (also: low bed) for armored vehicles (22 ton)
Sd.Anh. 119	(2 Achsig) für 100 PS-Motorboot	trailer (2 axle) for motorboat (100 HP Type MB 41)
Sd.Anh. 120	(2 Achsig) für 250 PS-Motorboot	trailer (2 axle) for motorboat (250 HP Type MB 42)
Sd.Anh. 121	Tiefhladeanhänger für PzKfpWg 65 ton	trailer (6 axle) low boy (also: low bed) for armored vehicles (65 ton)
Sd.Anh. 127	(2 Achsig) Mastanhänger	trailer (2 axle) for mast antenna
Sd.Anh. 141	(2 Achsig) für Pionier-Landungs-Fahrzeug 20-ton	trailer (2 axle) for engineer landing vehicle (20ton)
Sd.Anh. 201	(2 Achsig) für 8,8cm Flak	trailer (2 axle) for 8.8cm antiaircraft gun
Sd.Anh. 202	(2 Achsig) für 8,8cm Flak 37/37	trailer (2 axle) for 8.8cm antiaircraft gun Model 36/38
Sd.Anh. 202	(2 Achsig) für 8,8cm Flak 41	trailer (2 axle) for 8.8cm antiaircraft gun Model 41
Sd.Anh. 203	(2 Achsig) für 10,5cm Flak 38/39	trailer (2 axle) for 10.5cm antiaircraft gun Model 38/39
Sd.Anh. 203	(2 Achsig) für Fahrgerüst für schwere 12,8cm Flak (o)	trailer (2 axle) for mobilizing the static, heavy 12.8cm antiaircraft gun
Sd.Anh. 203	(2 Achsig) Transportbrücke für 12,8cm Flak-Zwilling	trailer (2 axle) for 12.8cm twin antiaircraft gun
Sd.Anh. 204	(2 Achsig) für 5cm Flak 41	trailer (2 axle) for 5cm antiaircraft gun Model 41
Sd.Anh. 204	(2 Achsig) für 200cm Flak-Scheinwerfer	trailer (2 axle) for 200cm antiaircraft searchlight
Sd.Anh. 204	(2 Achsig) für Maschinensatz für 200cm Flak-Scheinwerfer	trailer (2 axle) for generator for 200cm antiaircraft searchlight
Sd.Anh. 204	(2 Achsig) für Maschinensatz 60 kW	trailer (2 axle) for generator Model 60Kw
Sd.Anh. 204	(2 Achsig) für Sperrballonwinde	trailer (2 axle) for winch for barrage balloon
Sd.Anh. 205	(2 Achsig) Rohrwagen für 10,5cm Flak	trailer (2 axle) for barrel wagon for 10.5cm antiaircraft gun
Sd.Anh. 206	(2 Achsig) für 5,5cm Flak 58	trailer (2 axle) for 5.5cm antiaircraft gun Model 58
Sd.Anh. 206	(2 Achsig) für 3,7cm Flak-Zwilling 43	trailer (2 axle) for 3.7cm dual antiaircraft gun Model 43
Sd.Anh. 206	(2 Achsig) für 200cm Flak-Scheinwerfer 44	trailer (2 axle) for 200cm antiaircraft searchlight Model 44
Sd.Anh. 206	(2 Achsig) für Maschinensatz 120 kW	trailer (2 axle) for generator Model 120Kw
Sd.Anh. 206	(2 Achsig) für Funkmessgerät	trailer (2 axle) for antiaircraft radar
Sd.Anh. 206	(2 Achsig) für Flakrakete H3 117 "Schmetterling"	trailer (2 axle) for antiaircraft rocket Model Hs 117 "Schmetterling" (Butterfly)
Sd.Anh. 220	(4 Achsig) für Funkmessgerät	trailer (4 axle) for radar system
Sd.Anh. 220	(4 Achsig) für 12,8cm Flak 40/1	trailer (4 axle) for 12.8cm antiaircraft gun Model 40/1
Sd.Anh. 301	(1 Achsig) für Tankspritze	trailer (1 axle) for fire engine equipment (auxiliary for the fire engine)
Sd.Anh. 302	(1 Achsig) für Schlauchtender	trailer (1 axle) for mobile fire fighting (for independent operation)
Sd.Anh. 319	für Fla-Rakete "Wasserfall"	trailer for antiaircraft rocket "Wasserfall" (Waterfall)
Sd.Anh. 322	für A2 (o) 7,5-ton mit geschlossenem Aufbau	trailer for rocket A2 (o) with enclosed body (7.5 ton)
Sd.Anh. 322/2	für Landescheinwerfer (Gl 1500)	trailer for 1500cm landing searchlight Model Gl 1500
Sd.Anh. 322/3	für Landescheinwerfer (HgLL 1500)	trailer for 1500cm landing searchlight Model Hg LL 150
Sd.Anh. 350	für B2 (3-ton) (o) mit geschlossenem Aufbau	trailer B2 with enclosed body (civilian type)(3-ton)
Sd.Anh. 350/7	Fernsprechvermittlungs-Anhänger	telephone exchange trailer
Sd.Anh. 350/32	Leuchfeueranhänger	generator trailer for airfield beacons
Sd.Anh. 350/33	Leuchfeueranhänger	generator trailer for airfield beacons
Sd.Anh. 350/32	Prüf- und Wartungs-Anhänger für Bordfunk- und Peilgerät	trailer for maintenance and testing of aircraft radio and radar equipment
Sd.Anh. 350/43	Prüf- und Wartungs-Anhänger für Bordfunk- und Peilgerät	trailer for maintenance and testing of aircraft radio and radar equipment
Sd.Anh. 350/?	Anhänger B2 für Ladestation FR	trailer B2 with enclosed body (civilian type)(3-ton) for battery charger for V2 rocket units
Sd.Anh. 363	für B3 (4,5-ton) (o) mit geschlossenem Aufbau	trailer B3 with enclosed body (civilian type)(4.5-ton)
Sd.Anh. 363/1	für B3 (4,5-ton) (o) für Bildbearbeitung	trailer B3 with enclosed body (civilian type)(4.5-ton) for photograph production Type I
Sd.Anh. 363/2	für B3 (4,5-ton) (o) für Bildbearbeitung	trailer B3 with enclosed body (civilian type)(4.5-ton) for photograph production Type II
Sd.Anh. 401	(1 Achsig) Feldküche als Anhänger	trailer (1 axle) mobile field kitchen ("Gulaschkanone")
Sd.Anh. 422	(1 Achsig) Navigations-Funkpeilanhänger	trailer (1 axle) for direction finding equipment for navigation
Sd.Anh. 447	(2 Achsig) Navigations-Funkpeilanhänger	trailer (2 axle) for direction finding equipment for navigation
Sd.Anh. 450	(2 Achsig) Tragflächen 6 Meter	trailer (2 axle) for transporting wings (6 meters)
Sd.Anh. 451	(2 Achsig) Tragflächen 10 Meter	trailer (2 axle) for transporting wings (10 meters)
Sd.Anh. 450	(2 Achsig) Tragflächen 6 Meter	trailer (2 axle) for wings (6 meters)
Sd.Anh. 454	(2 Achsig) Flugbetriebsstoffkessel-Anhänger	trailer (2 axle) bowser for aircraft fuel
Sd.Anh. 458	(2 Achsig) Waffenabwurfgerät-Anhänger	trailer (2 axle) for bomb transport
Sd.Anh. 459	(2 Achsig) Waffenabwurfgerät-Anhänger	trailer (2 axle) for bomb transport
Sd.Anh. 469	(2 Achsig) Fernschreib-Anschlussanhänger	trailer (2 axle) with enclosed body for telephone switchboard
Sd.Anh. 470	(2 Achsig) Funkanhänger (Kurz- /Langwelle)	trailer (2 axle) with enclosed body for short and medium wave radio station
Sd.Anh. 471	(2 Achsig) Betriebs-Funkempfängeranhänger	trailer (2 axle) with enclosed body for radio receiver operation station
Sd.Anh. 472	(2 Achsig) leichter Leuchfeueranhänger	trailer (2 axle) with enclosed body light generator for airfield beacons
Sd.Anh. 473	(2 Achsig) mittlerer Leuchfeueranhänger	trailer (2 axle) with enclosed body medium generator for airfield beacons
Vsah. = Versuchsanhänger	Experimental Trailers	
Vsah. 642	Tiefhladeanhänger für Panzerkampfwagen	medium tank transport trailer
Vsah. 654	Tiefhladeanhänger für Panzerkampfwagen	light tank transport trailer
Anhänger	Trailers without numbers	
(1 Achsig) Anhänger-Fahrgestell 900 kg	trailer (1 axle) chassis (900 kilos)	
(1 Achsig) Anhänger-Fahrgestell 1500 kg Baumuster 41	trailer (1500 axle) chassis Model 41 (1500 kilos)	
(1 Achsig) Anhänger-Fahrgestell 1900 kg	trailer (1 axle) chassis (1900 kilos)	
(1 Achsig) Anhänger-Fahrgestell gl. 500 kg	trailer (1 axle) chassis cross-country capable (500 kilos)	
(1 Achsig) Anhänger-Fahrgestell gl. 900 kg	trailer (1 axle) chassis cross-country capable (900 kilos)	
(1 Achsig) Anhänger-Fahrgestell gl. 1500 kg	trailer (1 axle) chassis cross-country capable (1500 kilos)	
(1 Achsig) Anhänger-Fahrgestell gl. 2200 kg	trailer (1 axle) chassis cross-country capable (2200 kilos)	
(1 Achsig) Anhänger A1 (0,5 t), offen (o)	trailer (1 axle) Model A1, civilian type, open (500 kilos)	
(1 Achsig) Anhänger A1 (0,5 t), offen (o) als Schlauchhaspel für Kfz. 346	trailer (1 axle) Model A1, civilian type, open (500 kilos), for hoses, towed by Kfz. 346	
(1 Achsig) Anhänger mit geschlossenem Aufbau (o) für Eisenbahn-Pionier	trailer (1 axle) civilian type, enclosed, for Railroad Engineers	
(1 Achsig) Anhänger mit geschlossenem Aufbau (o) für Kraftfahrzeug-Parkes	trailer (1 axle) civilian type, enclosed, for Motor Vehicle Parks	
(1 Achsig) Anhänger gl. für Einheitsbehälter für Kraftstoff	trailer (1 axle) cross-country capable, for standard fuel cans ("Jerry cans")	
(1 Achsig) Anhänger für 200-Liter Kraftstoff-Fass	trailer (1 axle) fuel barrel (200 liters)	
(1 Achsig) Anhänger für 2x 200-Liter Kraftstoff-Fass	trailer (1 axle) 2 fuel barrels (each 200 liters)	
(1 Achsig) Anhänger für Ladungswerfer	trailer (1 axle) for heavy spigot mortar of the engineers	
(1 Achsig) Anhänger für M.S. Boot (handelsüblichen Gerät) der Pioniere	trailer (1 axle) for civilian motor boat used by the engineers	
(1 Achsig) Anhänger mit Notstromaggregat 12kVA "Carfais" Diesel der Marine	trailer (1 axle) for diesel power generator "Carfais" for the Navy	
(1 Achsig) Anhänger mit Notstromaggregat 12kVA "Fimag" Bezin der Marine	trailer (1 axle) for gasoline power generator "Fimag" for the Navy	
(1 Achsig) Anhänger für schwere Panzerbüchse 41	trailer (1 axle) for heavy antitank rifle (PzBü 41)	

GERMAN SPECIAL MILITARY TRAILERS AND MILITARY TRAILERS

(1 Achsig) Anhänger für Räudegaszellen	trailer (1 axle) for gas bottles (gas used against mangle)
(1 Achsig) Anhänger für Verschluss-Sachen der Vermessungs- und Karten-Einheiten	trailer (1 axle) enclosed, lockable, for confidential material of the surveying and mapping units
(1 Achsig) Anhänger offen (o) für Veterinärgerät für Pferdelažarett	trailer (1 axle) civilian type, open, for veterinary equipment for veterinary hospital
(1 Achsig) Anhänger für V2.Abschussplattform	trailer (1 axle) for firing platform for V2 rocket units
(1 Achsig) Diesel-Eisbereiter als Anhänger	trailer (1 axle) for diesel powered ice maker
(1 Achsig) Brennschluss-Antennen-Anhänger für schiess Fernraketen-Batterien	trailer (1 axle) for antenna for establishing rocket-cut-off for V2 rocket units
(1 Achsig) Grosser Druckluftzeuger als Anhänger	trailer (1 axle) with large air compressor
(1 Achsig) Fallschirmjägerkarren als Anhänger für das Kettenkrad	cart (1 axle) for Kettenkrad for Fallschirmjäger (Parachute Infantry)
(1 Achsig) Grosse Feldküche als Anhänger	trailer (1 axle) for mobile large field kitchen range
(1 Achsig) Festungskabeltötkarren	cart (1 axle) for Fortress Signal Troops, with sodering and other equipment
(1 Achsig) Festungskabelmesskarren	cart (1 axle) for Fortress Signal Troops, with calibration and other equipment
(1 Achsig) schweren Grabenpflug (Entgiftungspflug) als Anhänger	trailer (1 axle) heavy plow, originally for decontamination, but also used for entrenching
(1 Achsig) Handkarren für leichten Ladungswerfer der Pioniere	hand cart (1 axle) for light spigot mortar of the engineers
(1 Achsig) kleiner Kabeltrommel-Anhänger für Fernraketen-Einheit	trailer (1 axle) for light cable drums for V2 rocket units
(1 Achsig) Leitstrahl-Antennen-Anhänger für FR-Einheit	trailer (1 axle) for guiding beam antenna for V2 rocket units
(1 Achsig) Leitstrahl-Kontroll-Anhänger für FR-Einheit	trailer (1 axle) for guiding beam instrumentation for V2 rocket units
(1 Achsig) Lichtbogen-Schweissmaschinensatz auf Anhängerfahrgestell 1500 t	trailer (1 axle) arch welding equipment on chassis Model 41 (1500 kilos)
(1 Achsig) Maschinensatz 110/220 V 24 Kw als Anhänger fahrbar	trailer (1 axle) generator (110/220 Volts, 24 kW)
(1 Achsig) Maschinensatz 220 V 6,5 Kw als Anhänger fahrbar	trailer (1 axle) generator (220 Volts, 6.5 kW)
(1 Achsig) Maschinensatz 220 V (Wechselstrom) 15/18 KVA der Sanitätstruppe	trailer (1 axle) generator (220 Volts, AC, 15 kVA) for the Medical Troops
(1 Achsig) Maschinensatz 220/380 (Drehstrom) 30 Kw als Anhänger fahrbar	trailer (1 axle) generator (220/380 Volts, DC, 30 kVA)
(1 Achsig) Motorspritze als Anhänger fahrbar (o)	trailer (1 axle) motor water pump (civilian type)
(1 Achsig) Anhänger leichter Sprühanhänger	trailer (1 axle) light decontamination spray unit
(1 Achsig) Tragkraftspritzen-Anhänger (Tsga 8)(Bauart 1937)	trailer (1 axle) fire fighting equipment, including a portable water pump Type Tsga 8/37
(1 Achsig) Tragkraftspritzen-Anhänger (Tsga 8)(Bauart 1939)	trailer (1 axle) fire fighting equipment, including a portable water pump Type Tsga 8/39
(1 Achsig) Tragkraftspritzen-Anhänger (o)	trailer (1 axle) fire fighting equipment, civilian type, including a portable water pump
(1 Achsig) Troganhänger fürEntgiftungskraftwagen (Kfz. 305/112) des S.H.D.	trailer (1 axle) for decontamination van of the S.H.D. ("Sicherheits- und Hilfedienst")
(1 Achsig) T-Stoff-Vorwärmer-Anhänger für FR-Einheit	trailer (1 axle) for warming fuel (T-Staff = Hydrogensuperoxyd) for the V2 rocket units
(1 Achsig) Wasser-Anhänger 100 liter	trailer (1 axle) bowser for water (1000 liters)
(2 Achsig) Anhänger A2 Einheits-Anhänger 1 t offen (o)	trailer (2 axle) Standard Model A2, civilian type, open (1 ton)
(2 Achsig) Anhänger A2 als Schlauchhaspel für Schlauchkraftwagen (Kfz. 346)	trailer (2 axle) Standard Model A2, civilian type, open (1 ton), for hoses, towed by Kfz. 346
(2 Achsig) Anhänger B2 Einheits-Anhänger 3 t offen (o)	trailer (2 axle) Standard Model B2, civilian type, open (3 ton)
(2 Achsig) Anhänger B2 mit Maschinensatz 220/380 V Drehstrom 60 Kw	trailer (2 axle) Standard Model B2, for generator (220/380 Volts, DC, 60 kVA)
(2 Achsig) Anhänger B3 Einheits-Anhänger 4,5 t offen (o)	trailer (2 axle) Standard Model B3, civilian type, open (4.5 ton)
(2 Achsig) Anhänger E5 Einheits-Anhänger 5 t offen (o)	trailer (2 axle) Standard Model E5, civilian type, open, (5 ton)
(2 Achsig) Anhänger E8 Einheits-Anhänger 8 t offen (o)	trailer (2 axle) Standard Model E8, civilian type, open, (8 ton)
(2 Achsig) Anhänger mit Anlage zum Nachfüllen des Sauerstoffbedarf von Kampfflugzeuge	trailer (2 axle) for filling Oxygen into fighter planes
(2 Achsig) Anhänger (Langholz) für 6 Auffahrtsschienen Brückengerät I.Z.	trailer (2 axle) for 6 ramps of Type I.Z. bridge (long pole equipment)
(2 Achsig) Anhänger mit mittlerer Betriebsstoffkesselanlage (o) der Luftwaffe	trailer (2 axle) with medium boiler tank for aviation fuel
(2 Achsig) Anhänger mit schwererBetriebsstoffkesselanlage (o) der Luftwaffe	trailer (2 axle) with heavy boiler tank for aviation fuel
(2 Achsig) Anhänger mit Feldballonwinde 40 der Artillerie	trailer (2 axle) with winch for observation ballon Model 40 of the artillery
(2 Achsig) Anhänger mit Flakkommandogerät Hazemeyer der Marine	trailer (2 axle) with antiaircraft fire direction computer Model Hazemeyer
(2 Achsig) Anhänger mit 2cm-Flak auf Socketlafette	trailer (2 axle) for 2 cm antiaircraft gun Model 30 on pedestal base
(2 Achsig) Anhänger mit Kessel für Flüssigsauerstoff für Fernraketen	trailer (2 axle) with tank for Liquid Oxygen for V2 rocket units
(2 Achsig) Anhänger mit Kurbelmast 30m der Nachrichtentruppen	trailer (2 axle) with extendable antenna (30 meters) for the Signal Troops
(2 Achsig) Anhänger 1,5 t für Raupenschlepper Ost	trailer (2 axle) for Raupenschlepper Ost (1.5 ton)
(2 Achsig) Anhänger für Schleppboot 200 PS der Pioniere	trailer (2 axle) for towing boat (200 HP) of the Engineers
(2 Achsig) Anhänger schwimmfähig für Land-Wasser-Schlepper (Kässbohrer)	trailer (2 axle) for the amphibious truck ("LWS")(made by Kässbohrer)
(2 Achsig) Entgiftungsgeräte-Anhänger für den Entgiftungsgerätek. (Kfz. 305/12)	trailer (2 axle) for the decontamination equipment truck (Kfz. 305/12)
(2 Achsig) Kabeltrommel-Anhänger für FR-Einheiten	trailer (2 axle) for cable drums for V2 rocket units
(2 Achsig) Kfz. Werkstatt-Kessel für FR-Einheiten	trailer (2 axle) with motor maintenance shop for V2 rocket units
(2 Achsig) Landebahn-Leuchtanhänger	trailer (2 axle) for runway lighting
(2 Achsig) Luftverdichter-Anhänger für FR-Einheiten	trailer (2 axle) for air compressor for V2 rockets
(2 Achsig) Omnibus-Anhänger (Kässebohrer Type P4 1939)	trailer (2 axle) for motor bus (bus Model P4 1939)(made by Kässebohrer)
(2 Achsig) Rohrwagen 40 für 12,8cm Flak 40	trailer (2 axle) for 12,8cm antiaircraft gun barrel
(2 Achsig) Sägevollgater auf Anhänger	trailer (2 axle) for mobile buzzsaw
(2 Achsig) Scheinwerfer-Transportwagen für Scheinwerfer G150 (alter Art)	trailer (2 axle) for 150cm searchlight Model G150 (old type)
(2 Achsig) Scheinwerfer-Transportwagen für Scheinwerfer G110	trailer (2 axle) for 110cm searchlight Model G110
(2 Achsig) Strabo-Kran 16t als Anhänger	trailer (2 axle) for 16 ton collapsible crane (made by Strabo)
(2 Achsig) Tragflächen-Transportanhänger a & b (Bauart 39)	trailer (2 axle) for transport of aircraft wings Type a and b, Model 39
(2 Achsig) V2 Transport-Anhänger Vidal	trailer (2 axle) for transporting a V2 rocket (made by Vidal)
(2 Achsig) Wasserstoffverdichter-Anhänger 41+42	trailer (2 axle) for Hydrogen compression Model 41+42
(2 Achsig) Wasserstoffentwickler-Anhänger 40+41	trailer (2 axle) for Hydrogen developing Model 40+41
(3 Achsig) Anhänger 8 t für 800 PS Motorboot 43	trailer (3 axle) (8 ton) for motor boat Model 53 (800 HP)
(3 Achsig) Anhänger offen (o) mit Nutzlast 11.000 kg	trailer (3 axle) cargo, civilian type, open (11 ton)
(3 Achsig) Anhänger mit 30-t Kran	trailer (3 axle) for 30-ton collapsible crane
(3 Achsig) Anhänger schwimmfähig mit Nutzlast von 10 t	trailer (3 axle) amphibious (10 ton)
(3 Achsig) Anhänger schwimmfähig mit Nutzlast von 20 t	trailer (3 axle) amphibious (20 ton)
(3 Achsig) Anhänger für die Fernrakete A4 (V2) Fabrikat Meiller	trailer (3 axle) for transporting a V2 rocket (made by Meiller)
(4 Achsig) Anhänger für schwere Lasten Culemeyer	trailer (4 axle) for heavy cargo (made by Culemeyer)
(6 Achsig) Anhänger für schwere Lasten Culemeyer bis 60 t	trailer (6 axle) for heavy cargo (60 ton) (made by Culemeyer)
(6 Achsig) Anhänger für schwere Lasten Gothaer Waggonfabrik bis 60 t	trailer (6 axle) for heavy cargo (60 ton) (made by Gothaer Waggonfabrik)
(Mehrachts) Anhänger für schwere Lasten bis 110 t	trailer (multi-axle) for heavy cargo (110 ton)
(Mehrachts) Anhänger für schwere Lasten bis 150 t	trailer (multi-axle) for heavy cargo (150 ton)
(Mehrachts) Anhänger mit geschlossenem Aufbau für Zinkdruckrotationspresse	trailers (multi-axle) with enclosed body for zincograph rotating printing press

Pf. = Pionierfahrzeuge	Engineer Vehicles
Pf. 10 (2 Achsig) Bockwagen	trailer (2 axle) for bridge tressels
Pf. 11 (2 Achsig) Pontonwagen	trailer (2 axle) for bridge pontoons
Pf. 12 (2 Achsig) Rampenwagen	trailer (2 axle) for bridge ramps
Pf. 13 (1 Achsig) für M-Boot (100 PS MB 41)	trailer (1 axle) for motorboat (100 HP Type MB 41)

Note:

The designation of these four engineer trailers was a holdover from an earlier period; the old nomenclature was maintained, except that Pf. 13 is mentioned also as Sd.Anh. 13.

GERMAN HORSE-DRAWN VEHICLES: WAGONS – CARTS — SLEDS

Af	= Artilleriefahrzeuge	Artillerie Vehicles
Af 3	Munitionswagen 96 n.A.	ammunition limber Type 96 n.A.
Af ?	Munitionshinterwagen 96 n.A.	ammunition rear limber Type 96 n.A.
Af 4	Feldhaubitzen-Munitionswagen	field howitzer ammunition wagon 98
Af 5	schwerer Munitionswagen 02	heavy ammunition wagon 02
Af 7	Rohrwagen für 10cm K17	barrel wagon – 10cm Gun (K17)
Af 8	Rohrwagen für 15cm K16	barrel wagon – 15cm Gun (K16)
Af 12	Boebachtungswagen	artillery observation wagon
Af 14	Munitionswagen	ammunition wagon
Af 19	Rohrwagen für 10cm K18 oder sFH 18	barrel wagon – 10cm Gun or 15cm sFH
Af ?	Feldhaubitze	limber for field howitzer
Af ?	Munitionshunterwagen 98	ammunition rear limber Type 98
Af ?	Munitionswagen 38 für 7,5cm Feldkanone 38	ammunition limber for 7,5cm field gun
Af ?	Feldkanonenprotze für 7,5cm Feldkanone 38	limber for 7,5cm field gun 38
Af ?	leichte Feldhaubitze 98E	limber for light field howitzer 98E
Af ?	leichte Feldhaubitze 18	limber for light field howitzer 18
Af ?	leichte Feldhaubitze 18/40	limber for light field howitzer 18/40
Af ?	schwerer Feldhaubitzen-Munitionswagen	heavy field howitzer ammunition wagon

EF	= Ersatzfeldwagen	Replacement Field Wagon
EF40	Wirtschaftswagen	supply wagon

Hf	= Heeresfahrzeug	Army Vehicles
Hf 1	leichter Feldwagen (gefedert)	light field wagon (sprung)
used as	Verpflegungswagen	rations wagon
	Sanitätsträgerwagen	stretcher bearer wagon
	Packwagen	baggage wagon
	Veterinärmitelwagen	veterinary equipment wagon
	Schanzzeugwagen	entrenching equipment wagon
Hf 1/1	grosser Gefechtswagen	large combat wagon
used as	Nachrichtengerätswagen (gefedert)	signal equipment wagon (sprung)
	Pioniergerätswagen (gefedert)	engineer equipment wagon (sprung)
	Vermessungsgerätswagen (gefedert)	survey equipment wagon (sprung)
Hf 1/2	Handscheinwerferwagen (M)	hand held searchlight wagon
Hf 1/3	Handscheinwerferwagen (S)(gefedert)	hand held searchlight wagon (sprung)
Hf 1/4	Beobachtungs-Gerätswagen	observation equipment wagon
Hf 1/11	grosser Gefechtswagen	large combat wagon
used as	Nachrichtengerätswagen	signal equipment wagon
Hf 1/13	grosser Fahnschmiedwagen	large farrier wagon
Hf 1/14	Packwagen für Feldschmiede	field forge wagon
Hf 1/14	Waffenmeisterwagen	armorer wagon
Hf 1/16	Bäckereigerät-Wagen	bakery equipment wagon
Hf 1/18	Truppensanitäts-Wagen	medical equipment wagon
Hf 2	schwere Feldwagen	heavy field wagon
used as	Gerätswagen	equipment wagon
	schwerer Gefechtswagen	heavy combat wagon
	Lastwagen	cargo wagon
	Munitionswagen	ammunition wagon
	Packwagen	baggage wagon
	Verpflegungswagen	rations wagon
	Vorratswagen	stores wagon
Hf 3	kleiner Feldwagen	small field wagon (600 kilo)
Hf 3/1	Nachrichtengerätswagen (gefedert)	signal wagon (sprung)
Hf 3/2	leichter Frenspchswagen (gefedert)	ligh telephone wagon (sprung)
Hf 3/11	kleiner Gefechtswagen	small combat wagon
Hf 3/12	kleiner Fahnschmiedwagen	small farrier wagon
Hf 4	Gebirgskarren	mountain cart
Hf 7	Stahlfeldwagen (gefedert)	field wagon (steel)(sprung)
Hf 7/11	grosser Gefechtswagen (Stahlfeldwagen)	large combat wagon (steel)
Hf 7/13	grosser Fahnschmiedwagen (Stahlfeldwagen)	large farrier wagon (steel)
Hf 7/14	Waffenmeisterwagen (Stahlfeldwagen)	armorer wagon (steel)
Hf 8	Bockwagen	tressel transport wagon
Hf 9	Pontonwagen	pontoon transport wagon
Hf 11	grosser Feldküche	large field kitchen
Hf 12	kleiner Feldküche	small field kitchen
Hf 13	grosser Feldküche	large field kitchen
Hf 14	kleiner Feldküche	small field kitchen
Hf ?	Munitionswagen	ammunition wagon
Hf ?	Vorratswagen	supply wagon
Hf ?	Sanitätswagen	medic wagon
Hf ?	Veterinärvorratswagen	veterinary supply wagon

GERMAN HORSE-DRAWN VEHICLES: WAGONS – CARTS — SLEDS

If	= Infanteriefahrzeuge	Infantry Vehicles
If 3	Maschinengewehr-Wagen (s) (2 sMG)	heavy machine gun wagon (2 HMG)
If 4	Maschinengewehr-Wagen (1) (2 sMG)	light machine gun wagon (2 HMG)
If 4	Gebirgskarre	mountain cart
If 5	Maschinengewehrwagen (Zwillingssockel)	machine gun wagon (with pedestal for dual MG)
If 6	Gefechtskarre für s Gr.Wfr. /m. Gr.Wfr.	medium & heavy mortar wagon
If 7	Maschinengewehrwagen (1 sMG)	machine gun wagon (1 HMG)
If 7/24	Maschinengewehrwagen (MG7/24 Schwarzlose)	machine gun wagon (for HMG 7/24 Scharzloser)
If 8	Tornister-Funktrupp-Wagen	pack radio wagon
If 9	Gefechtskarre	combat cart
If 9/1	Gefechtskarre für 8cm Granatwerfer	combat cart for 8cm mortar
If 9/1	Munitionskarre für 8cm Granatwerfer	ammunition cart for 8cm mortar
If 12	Beobachtungswagen	observation wagon
If 12/1	leichte Infantriegeschützprotze	limber for light infantry gun
If 14	Munitionswagen	ammunition wagon
If 15	Beobachtungswagen	observation wagon
If ?	Gebirgskarre für 3,7cm Pak	mountain cart for 3,7cm antitank gun
If ?	Granatwerferkarre mit Rahmen M.24/25	mortar cart with frames

Nf	= Nachrichtenfahrzeuge	Signal Vehicles
Nf 1	schwerer Fernsprechwagen	heavy telephone wagon
Nf 2	leichter Fernsprechwagen	light telephone wagon
Nf 4	kleiner Funkwagen	small radio wagon
Nf 5	kleinfunkwagen	small radio wagon
Nf 6	Funkwagen	radio wagon
Nf 7	Infanterie-Nachrichtenwagen	infantry signal wagon
Nf ?	Bauwagen 13	construction equipment wagon
Nf ?	Leiterwagen für Fernsprechrupp	ladder wagon for telephone section
Nf ?	Kastenwagen für Fernsprechrupp	equipment wagon for telephone section

Pf	= Pionierfahrzeuge	Engineer Vehicles
Pf 21	Flammenwerfer-Füllwagen	flamethrower refill wagon
Pf 22	Pionierhandkarren	engineer hand cart
Pf 25	Handkarren für leichten Landungswerfer	hand cart for light spigot mortar

Sf	= Sanitätsfeldwagen	Medical Field Wagons
Sf 1	Krankenwagen	ambulance wagon
Sf 2	Krankenwagen	ambulance wagon

Vf	= Fahrzeuge der Veterinärtruppen	Wagons for Veterinary Troops
Vf 1	Pferdetransportwagen	horse transport wagon

Vwf	= Fahrzeuge der Verwaltungstruppen	Wagons for Administration Troops
Vwf 1	Backofentransportwagen	oven transport wagon
Vwf 2	Teigknetwagen	dough mixer wagon
Vwf 3	Kraftquellenwagen	water pump wagon

Fahrzeuge ohne Numerierung	Wagons without Numbers
— Pleskau-Wagen I	Pleskau I (359 kilo) (1 horse team)
— Pleskau-Wagen II	Pleskau II (700 kilo) (2 horse team)
— Kutschwagen	carriage / coach
— grosser Feldwagen (t)	large Czech field wagon
— kleiner Feldwagen (t)	small Czech field wagon
— grosser Feldküche (t)	large Czech field kitchen
— kleiner Feldküche (t)	small Czech field kitchen
— Gebirgskarren M15 für Munition (t)	Czech mountain cart for ammunition

Hs	= Heeresschlitten	Army Sleds
Hs 1	Schlitten (300 Kg)	sled (300 Kilo) (single or tandem)
Hs 3	Schlitten (500 Kg)	sled (500 Kilo) (single or tandem)
Hs 3/1	Krankenschlitten	stretcher sled (single or tandem)
Hs 5	Schlitten (1000 Kg)	sled (1000 Kilo) (single or tandem)
Hs 41	zweispännige Schlitten	sled (dual)
Hs 42	zweispännige Schlitten	sled (dual)
Hs 43	zweispännige Schlitten	sled (dual)
Hs 61	einspännige Schlitten	sled (single)
Hs 62	einspännige Schlitten	sled (single)

GERMAN ARMY RANKS AND *STELLEGRUPPEN* (BILLET GROUPS)

This is only a simplified account of the German military personnel structure and hierarchy. Readers are warned that, as in all armies, they were in actual fact more complicated, with important differentiations being made between designations of rank, billet, function, and skill.

'Billet' indicates an appointment to (staffing of) a position – also called a 'slot' – like Squad Leader, Platoon Commander, Divisional Commander, Executive Officer, Supply Sergeant, etc. Confusingly, in some cases, the billet has the same designation as a rank, such as Hauptfeldwebel.

The equivalent Ranks given in English are neither completely World War II British nor American, and is not going to satisfy any specialist. (However a specialist would probably not be reading this anyway). Nearly all German officer ranks correspond to US Army ranks, although their terminology differs, a *Generalmajor* being the equivalent of a brigadier general. Modern US Army rank equivalents have some differences. There is one more enlisted rank (Command Sergeant Major), and one more Warrant Officer rank (Warrant Officer 3rd Class). US Army Warrant Officers are counted as officers, not enlisted men. In the German WWII Army, all ranks below 2nd Lieutenant were enlisted men.

The German Army divided officers billets into eight groups, depending on the function to be carried out. German wartime officer ranks were permanent, which often made it impossible for German officers to be promoted to the higher rank which their wartime billet would actually have warranted. For example, although a Captain normally staffed the billet of Company Commander, this was not always a rule. If there were not enough Captains then a senior member of a lower rank was assigned to that billet. Conversely, if there were too many of a higher rank than one or more might be assigned a lower ranking billet. Many Divisions were commanded by a Brigadier General - and even an occasional Colonel - instead of a Major General. Conversely, if a billet was particularly critical, a higher-ranking person might be assigned to that billet than would normally be the case. Skill was preferred to rank. Promotion was achieved by serving time. The function or billet filled as such was not a ground for promotion.

The enlisted men were divided into three billet groups: Senior Sergeants (Unteroffiziere mit Portepee) ("O" Group), Junior Sergeants (Unteroffiziere ohne Portepee) ("G" Group), and Other Ranks (Mannschaften) ("M" Group).

Enlisted members of the German Army had an 'Occupation' (Laufbahn), i.e. a career or field of specialty, like Infantry, Supply, Finance and so on. The occupation might be incorporated into the rank designation, such as *Beschlagschmiedobergefreiter*, a farrier (horseshoe smith) corporal; or even be used instead of the rank designations, such as *Beschlagmeister*, ('Farrier Master'), who was an expert farrier sergeant.

The highest combat leader position held by an enlisted man was that of platoon leader. However, this usually applied only to the third and fourth platoons. All other combat command positions were held by officers. Sergeants and Warrant Officers were in charge of logistics and administration, freeing the officers for their primary function of leading men into combat. It was not unusual for senior enlisted men to become involved in combat when the need arose, although the German Army considered it a waste of skilled manpower to use these highly trained and experienced men for this purpose.

German Tables of Organization (KStN – *Kriegsstärkenachweisungen*) had many notes indicating which billets and specialist slots were to be filled with what ranks and specialists, listing which billets had priority over others, which could alternatively be filled by a person with specialized knowledge or skill, and which billets should by preference be filled with regular army personnel.

Although it was expected to have rank and billet corresponding to each other, this was far from the case. Specialist personnel was rare and many units were raised in a hurry, not having enough time to acquire all its correct personnel. And once a unit entered combat, the chances of acquiring the exact, highly-skilled soldier for the correct position often became merely a matter of luck.

The German Wehrmacht also had a unique category of personnel within its ranks, namely the *Wehrmachtbeamten*, which can be loosely translated as Armed Forces Civil Servants or as Government Service Officials. They were found in administrative, legal, and technical service positions. They were civilians performing functions within the Armed Forces. Although they were not classified as soldiers, they wore uniforms identical with those of the Service branch they were serving with, albeit with different insignia. Their duties, at least at field and company level, could lead to armed encounters with enemy forces, and they were all armed with pistols.

Generals

Billet Group "A"

Commander-in-Chief / General Officer in an "A" Group
Oberbefehlshaber / General in A-Stelle
 Generalfeldmarschall General of the Army (Field Marshal)
 Generaloberst General

Billet Group "F"

Commanding General / General Officer in an "F" Group
Kommandierender General / General in F-Stelle
 General Lieutenant General
 der Infanterie of the Cavalry
 der Kavallerie of the Infantry
 der Artillerie of the Artillery
 der of the ...

Billet Group "D"

Divisional Commander / General Officer in a "D" Group
Divisionskommandeur / General in D-Stelle
 Generalleutnant Major General
 Generalstabsarzt Major General (Medical Corps)
 Generalstabs- Major General (...)

Billet Group "I"

Infantry, Artillery, or Brigade Commander / General Officer in an "I" Group
Infanterie-, Artillerie-, Brigadekommandeur / Offizier in I-Stelle
 Generalmajor Brigadier General
 Generalarzt Brigadier General (Medical Corps)
 General- Brigadier General (...)

Officers

Billet Group "R"

Regimental Commander / Officer in an "R" Group
Regimentskommandeur / Offizier in R-Stelle
 Oberst Colonel
 Oberstarzt Colonel (Medical Corps)
 Oberst- Colonel (...)

Billet Group "B"

Battalion Commander / Officer in a "B" Group
Abteilungs- bzw. Bataillonskommandeur / Offizier in B-Stelle
 Oberstleutnant Lieutenant Colonel
 Oberfeldarzt Lieutenant Colonel (Medical Corps)
 Oberfeld- Lieutenant Colonel (...)
 Major Major
 Oberstabsarzt Major (Medical Corps)
 Oberstabs- Major (...)

Billet Group "K"

Battery, Squadron, or Company Commander / Officer in a "K" Group
Batterie-, Schwadron- bzw. Kompanieführer / Offizier in K-Stelle
 Hauptmann Captain
 Rittmeister Captain (Cavalry Corps)
 Stabsarzt Captain (Medical Corps)
 Stabsveterinär Captain (Veterinary Corps)
 Stabsmusikmeister Captain (Band)
 Stabs- Captain (...)

Billet Group "Z"

Platoon Leader / Officer in a "Z" Group
Zugführer / Offizier in Z-Stelle
 Oberleutnant First Lieutenant
 Oberarzt First Lieutenant (Medical Corps)
 Obermusikmeister First Lieutenant (Band)
 Oberzahlmeister First Lieutenant (Paymaster Corps)
 Ober- First Lieutenant (...)
 Leutnant Second Lieutenant
 Assistenzarzt Second Lieutenant (Medical Corps)
 Musikmeister Second Lieutenant (Band)
 Assistenzzahlmeister Second Lieutenant (Paymaster Corps)
 Assistenz- Second Lieutenant (...)

Enlisted Men

Billet Group "O"

Senior Non-Commissioned Officer in an "O" Group
Oberfeldwebel (Unteroffiziere mit Portepee)
 Stabsfeldwebel Warrant Officer First Class
 Obermeister Warrant Officer 1st Class of a Technical Establishment
 Hauptfeldwebel Warrant Officer 2nd Class
 Hauptwachtmeister Warrant Officer 2nd Class (Cavalry, Artillery, AA, etc.)
 Oberfeldwebel Sergeant Major
 Oberwachtmeister Sergeant Major (Cavalry, Artillery, AA, etc.)
 Musikleiter Sergeant Major (Band)
 etc.
 Feldwebel First Sergeant
 Wachtmeister First Sergeant (Cavalry, Artillery, AA, etc.)
 Beschlagmeister Farrier First Sergeant
 Feuerwerker Ordnance First Sergeant
 Brieffaubenmeister Pigeon Postmaster
 etc.

Billet Group "G"

Non-Commissioned Officer in a "G" Group
Gruppenführer (Unteroffiziere ohne Portepee)
 Unterfeldwebel Staff Sergeant
 Unterwachtmeister Staff Sergeant (Cavalry, Artillery, AA, etc.)
 etc.
 Unteroffizier Sergeant
 Sanitätsunteroffizier Sergeant (Medical Corps)
 etc.
 Obergefreiter Corporal
 Sanitätsobergefreiter Corporal (Medical Corps)
 etc.

Billet Group "M"

Other Rank in an "M" Group
Mannschaft
 Gefreiter Private First Class
 Oberschütze Private 2
 Oberreiter Trooper First Class
 etc.
 Schütze Private 1 (infantryman)
 Grenadier Private (alternate designation for infantryman)
 Jäger Private (Mountain or Light Infantry)
 Pionier Engineer / Pioneer (Engineers)
 Fahrer Driver (usually of a horse-drawn vehicle)
 Kraftfahrer Driver (motor vehicle)
 Beschlagschmiedschütze Farrier (horse smith)
 Spielman Bandsman / Bugler
 etc.

GERMAN MILITARY PERSONNEL JOB DESCRIPTIONS

Abteilungsarzt	Battalion Physician	Melder	Messenger / Runner
Abteilungskommandeur	Battalion Commander	Meldereiter	Messenger (horse-mounted)
Abteilungsschreiber	Battalion Headquarters Clerk	Mitarbeiter	Assistant Clerk
Abteilungsveterinär	Battalion Veterinary Doctor	Motorschlosser	Motor Mechanic
Adjutant	Adjutant	Munitionskanonier	Ammunition Handler
Arzt	Physician	Munitionsschütze	Ammunition Handler
Auswerter	Plotter / Evaluator	Musiker	Bandsman
Autoschlosser	Motor Vehicle Mechanic	Musikmeister	Band Leader
Bataillonsarzt	Battalion Physician	Nachrichtenmechaniker	Signals Technician
Bataillonskommandeur	Battalion Commander	Nachrichtenoﬃzler	Signal Officer
Bataillonsveterinär	Battalion Veterinary Doctor	Nachrichtenunteroﬃzler	Signal NCO
Batterieführer	Battery Commander	Oﬃzler	Officer
Batterieoﬃzler	Firing Battery Commander	Ordnanzoﬃzler	Aid (-de-Camp) (officer)
Batterieschreiber	Battery Headquarters Clerk	Ordnanz	Orderly (enlisted)
Beamte	Armed Forces Civil Servant / Government Service Official / Civilian Employee in Military Service	Panzerbüchenschütze	Antitank Rifleman
Beobachter	Observer	Panzerelktromechaniker	Armored Vehicle Electrician
Beobachtungsoﬃzler	Observation Officer	Panzerelktroschweisser	Armored Vehicle Arc Welder
Beschlagschmied	Farrier / Horseshoe Smith	Panzerführer	Armored Vehicle Commander
Betreuungsoﬃzler	Entertainment Officer	Panzerfunkwart	Armored Vehicle Radio Repairman
Bootsmann	Boat Operator	Panzergetriebenschlosser	Armored Vehicle Drive Train Mechanic
Chef des Stabes	Chief of Staff	Panzerjägerführer	Antitank Vehicle Commander
Divisionionsarzt	Division Physician	Panzermotorschlosser	Armored Vehicle Motor Mechanic
Divisionskommandeur	Division Commander	Panzerschlosser	Armored Vehicle Mechanic
Dolmetscher	Interpreter	Panzerschützen	Infantryman in an Armored Vehicle
Dreher	Lathe Operator	Panzerwart	Armored Vehicle Mechanic
Drucker	Printer	Peiler	Direction Finder
Elektriker	Electrician	Pferdeführer	Horse Leader. Driver on foot of a horse-drawn wagon
Elektromechaniker	Electro Mechanic	Pferdehalter	Horse Holder (Groom)
Entfernungsmesser	Rangefinder / Distance Measurer	Pferdewärter	Groom (Horse Holder)
Erkunder	Scout	Pionier	Pioneer / Engineer / Sapper
Erkundungsoﬃzler	Observation Officer	Planoffizier	Triangulation Officer
Facharbeiter	Specialist	Postfachkraft	Postal Worker
Fahnenschmied	Farrier NCO	Prüfer	Accounts Controller
Fahrer	Driver	Quartiermeister	Quartermaster
Fahrer vom Bock	Wagoner. (Driver of a horse-drawn vehicle sitting on the driver's box)	Rechner	Calculator
Fahrer vom Sattel	Horse Team Leaders. (Drivers of a horse-drawn vehicle sitting on the horses)	Rechnungsführer	Accountant
Feinmechaniker	Optics Technician	Regimentsadjutant	Regiment Adjutant
Feldfunksprecher	Field Radio Operator	Regimentsarzt	Regiment Physician
Feldgendarm	Military Policeman	Regimentskommandeur	Regiment Commander
Feldkoch	Cook	Regimentskraftfahreroﬃzler	Regiment Motor Officer
Feldkochunteroﬃzler	Cook NCO	Regimentschreiber	Regiment Headquarters Clerk
Feldwebel	Sergeant	Regimentsveterinär	Regiment Veterinary Doctor
Fernsprecher	Telephonist	Richter	Judge
Feuerwerker	Ordnance NCO	Richtkreisoﬃzler	Gun Layer NCO / Gun Director NCO
Flakwaffenwart	Antiaircraft Weapon Armorer	Richtmeister	Master Fitter
Flugmeldeauswerter	Air Observation Evaluator	Richtschütze	Gunner
Flugmelder	Air Observer	Sachbearbeiter	Clerk
Führer	Leader	Sanitätssoﬃzler	Medical Officer
Führer der Gefechtsfahrzeuge	Leader of the Company/Battery Vehicles	Sanitätsunteroﬃzler	Medical NCO
Funker	Radio Operator	Sattelpferd	Near Horse
Funkmeister	Senior Radio Operator	Sattler	Saddler / Harness Maker
Funkwart	Radio Repairman	Scharenfernrohrunteroﬃzler	Scissors Telescope NCO
Futtermeister	Fodder NCO	Schirmmeister	Foreman / Harness Keeper / Storekeeper NCO / Maintenance Technical Sergeant
Gaschützunteroﬃzler	Chemical Warfare NCO	Schleifer	Polisher
Gefechtsschreiber	Headquarters Clerk	Schlosser	Mechanic
Gerätverwalter	Equipment Administrator	Schmied	Smith
Gerätwart	Equipment Repairman	Schneider	Tailor
Geschützbedienung	Gun Crew	Schreiber	Clerk
Geschützführer	Gun Layer / Gun Captain / Gun Commander	Schumacher / Schuster	Shoemaker / Cobbler
Getreibeschlosser	Drive Train Mechanic	Schwadronführer	Company Commander (cavalry arm)
Gruppenführer	Section Leader	Schwadrontruppführer	Company Headquarters Section Leader (cavalry arm)
Handwerker	Craftsman	Schweisser	Welder
Hauptfeldwebel	Senior Company NCO / Company First Sergeant	Spähtruppführer	Scout Section Leader
Hauptwachmeister	Senior Battery NCO / Battery First Sergeant	Staffelführer	Detachment Leader
Hilfsbeobachter	Assistant Observer	Stellmacher	Cartwright / Wheelwright
Hilfsprüfer	Assistant Controller	Stellungsunteroﬃzler	Gun Position NCO
Hiwi (Hilfswilliger)	Foreign Volunteer for Military Service	Steuermann	Helmsman (driver of a boat)
Holzarbeiter	Wood Worker	Tankwart	Fuel Handler
Intendant	Commissary Officer	Tischler	Joiner / Cabinet Maker
Kanonier	Gunner	Trossführer	Trains Leader
Kartenzeichner	Cartographer	Truppenarzt	Troop Doctor
Kettenkraftradfahrer	Kettenrad Driver	Truppführer	Team Leader
Klempner	Plumber	Unteroﬃzler	NCO (Non-Commissioned Officer)
Koch	Cook	Urkundsbeamter	Document Clerk
Kommandant	Commandant	Verbindungssoﬃzler	Liaison Officer
Kommandeur	Commander	Vermessungsdienst	Measuring Service
Kompanieführer	Company Commander	Verpflegungsmann	Rations Handler
Kompanietrossführer	Company Trains Leader	Verpflegungsunteroﬃzler	Rations NCO
Kompanietruppführer	Company Headquarters Section Leader	Veterinärsoﬃzler	Veterinary Officer
Kradmelder	Motorcycle Messenger	Vorgeschobener Beobachter	Forward Observer
Kraftfahrzeugelektriker	Motor Vehicle Electrician	Vorhandwerker	Leading Craftsman
Kraftfahrzeugmotorschlosser	Motor Vehicle Motor Mechanic	Vorreiter	Outrider. Escort on horse-back of a horse-drawn vehicle.
Kraftfahrzeugschlosser	Motor Vehicle Mechanic	Vorwamer	Advance Warning Man
Kraftwagenbeifahrer	Motor Vehicle Codriver	Waffenmeister	Armorer
Kraftwagenfahrer	Motor Vehicle Driver	Waffenmeisterhilfe	Assistant Armorer
Krankenträger	Stretcher Bearer	Waffenmeisterunteroﬃzler	Master Armorer NCO
Ladeschütze	Loader	Waffenunteroﬃzler	Armorer NCO
Laufwerkschlosser	Running Gear Mechanic	Wagenbegleiter	Wagon Escort. Escort of a horse-drawn vehicle on foot
Leiter	Chief Leader	Wagenführer	Leader of the vehicles in the trains
Lichtpauser	Photographer	Werferführer	Launcher or Mortar Gunner
Maler	Painter	Werkmeister	Foreman / Chief Technician
Mann	(Enlisted) Man	Zahlmeister	Paymaster / Finance Officer
Mannschaft	Privat / Other Rank / (Enlisted) Man	Zeichner	Draftsman
Maschinengewehrschütze	Machine Gunner	Zimmermann	Carpenter
Meldefahrer	Motor Vehicle Messenger	Zugführer	Platoon Leader
Meldefahrer	Messenger (motor vehicle)	Zugtruppführer	Platoon Headquarters Section Leader